



BY CHUCK  
LAST UPDATED: 22/12/2020

*DCS GUIDE*  
*AV-8B N/A HARRIER II*

# TABLE OF CONTENTS

- PART 1 – INTRODUCTION
- PART 2 – CONTROLS SETUP
- PART 3 – COCKPIT & GAUGES
- PART 4 – START-UP PROCEDURE
- PART 5 – TAKEOFF
- PART 6 – LANDING
- PART 7 – ENGINE MANAGEMENT
- PART 8 – FLIGHT & AERODYNAMICS
- PART 9 – SENSORS
- PART 10 – OFFENCE: WEAPONS & ARMAMENT
- PART 11 – DEFENCE: RWR AND COUNTERMEASURES
- PART 12 – RADIO TUTORIAL
- PART 13 – AUTOPILOT
- PART 14 – NAVIGATION & ILS LANDING
- PART 15 – AIR-TO-AIR REFUELING
- PART 16 – VREST PAGE
- PART 17 – OTHER RESOURCES



Special thanks to Paul "Goldwolf" Whittingham for creating the guide icons.

The McDonnell Douglas AV-8B Harrier II (Night Attack) is a single-engine ground-attack aircraft that constitutes the second generation of the Harrier Jump Jet family. Capable of vertical or short takeoff and landing (V/STOL), the aircraft was designed in the late 1970s as an Anglo-American development of the British Hawker Siddeley Harrier, the first operational V/STOL aircraft.

The first-generation Harriers entered service with the Royal Air Force (RAF) and United States Marine Corps (USMC) in the late 1960s and early 1970s, but were handicapped in range and payload. In short takeoff and landing configuration, the AV-8A (American designation for the Harrier) carried less than half the 4,000 lb (1,800 kg) payload of the smaller A-4 Skyhawk, over a more limited radius. To address this issue, Hawker Siddeley and McDonnell Douglas began joint development of a more capable version of the Harrier in 1973.

The AV-8B Harrier II retains the basic layout of the Hawker Siddeley Harrier, with horizontal stabilizers and shoulder-mounted wings featuring prominent anhedral (downward slope). The aircraft is powered by a single Rolls-Royce Pegasus turbofan engine, which has two intakes and four synchronized vectorable nozzles close to its turbine. Two of these nozzles are located near the forward, cold end of the engine and two are near the rear, hot end of the engine. This arrangement contrasts with most fixed-wing aircraft, which have engine nozzles only at the rear. The Harrier II also has smaller valve-controlled nozzles in the nose, tail, and wingtips to provide control at low airspeeds.

Typically operated from small aircraft carriers, large amphibious assault ships and simple forward operating bases, AV-8Bs have participated in numerous military operations, proving themselves versatile assets. The aircraft took part in combat during the Gulf War and the Iraq War beginning in 2003. The Harrier II has served in Operation Enduring Freedom in Afghanistan since 2001, and was used in Operation Odyssey Dawn in Libya in 2011. Italian and Spanish Harrier IIs have taken part in overseas conflicts in conjunction with NATO coalitions. During its service history, the AV-8B has had a high accident rate, related to the percentage of time spent in critical take-off and landing phases.



The high accident rate I was mentioning before will very likely be applicable to the simulation world as well. Doing a vertical landing is much harder than meets the eye. The Harrier will test your skills as a pilot like never before.

The cockpit feels modern with its MPCDs (Multi-Purpose Color Displays) and Heads-Up Display and the AV-8B has a number of very powerful tools and sensors at its disposal like a Targeting Pod, a Jamming Pod and a Dual Mode Tracker. The Harrier seems to have been designed to be a Jack of all Trades that could be used in more or less any type of mission. You can operate from the cramped deck of the Tarawa, to remote FOBs (Forward Operating Base) where all you have to land is a small helipad. The Harrier will force you to manage your weight and make mental calculations if you need to perform difficult landings like a Vertical Landing. Aerodynamically speaking, the AV-8B is challenging since it is one of the few aircraft that can land pretty much anywhere. You'll see: swivelling nozzles can be more difficult to use than you would think. I tried to explain the best practices in related sections, but I'm sure you'll have a blast trying to figure out the best ways to fly this bird.

This makes it a very interesting experience since there are a lot of stuff to do in it. You will not feel like you are flying a next-gen fighter jet, but you will have a flexible aircraft that can give you lots of options. Think of an hybrid between an A-10 on steroids with a helicopter. This is why it is one of my favourite modules in DCS.

A lot of love was poured into this aircraft by RAZBAM, and it shows. The Harrier being currently in early access, some features are missing or simplified (RAZBAM said they were working on it, so please be patient), but despite that the Harrier feels very much like a proper study-level simulation that will have you learning ungodly amounts of cool things about the (very much) insane minds of the British engineers who first came up with the idea of the Harrier.



Note: In your controls, make sure you check your “Trim” controls since the default version of the game has your trim hat set to changing your view rather than trim the aircraft. Since most of you are probably equipped with a TRACKIR already, I suggest you make sure the Trim Hat Switch is set up properly.

**CONTROL OPTIONS**

AV8BNA | Axis Commands | Reset category to default | Clear category | Save profile as | Load profile

Action	Category	Keyboard	Saitek Pro Flight Co...	Joystick - HOTAS Wa...	Throttle - HOTAS W...	TI
Absolute Camera Horizontal View						
Absolute Camera Vertical View						
Absolute Horizontal Shift Camera View						
Absolute Longitude Shift Camera View						
Absolute Roll Shift Camera View						
Absolute Vertical Shift Camera View						
Camera Horizontal View						
Camera Vertical View						
Camera Zoom View						
Head Tracker : Forward/Backward						TI
Head Tracker : Pitch						TI
Head Tracker : Right/Left						TI
Head Tracker : Roll						TI
Head Tracker : Up/Down						TI
Head Tracker : Yaw						TI
Nozzle Angle					JOY_RZ	
Nozzle STO Stop						
Pitch				JOY_Y		
Roll				JOY_X		
Rudder			JOY_RZ			
TDC Slew Horizontal				JOY_X		
TDC Slew Vertical						
Thrust					JOY_Z	
Wheel Brake Left			JOY_X			

Modifiers | Add | Clear | Default | Axis Assign | Axis Tune | FF Tune | Make HTML

CANCEL | OK

To assign axis, click on Axis Assign. You can also select “Axis Commands” in the upper scrolling menu.

To modify curves and sensitivities of axes, click on the axis you want to modify and then click on “Axis Tune”.

Bind the following axes:

- PITCH (DEADZONE AT 0, SATURATION X AT 100, SATURATION Y AT 100, CURVATURE AT 15)
- ROLL (DEADZONE AT 0, SATURATION X AT 100, SATURATION Y AT 100, CURVATURE AT 15)
- RUDDER (DEADZONE AT 0, SATURATION X AT 100, SATURATION Y AT 100, CURVATURE AT 10)
- THRUST – CONTROLS ENGINE RPM
- NOZZLE – CONTROLS SWIVELLING NOZZLE ANGLE
- WHEEL BRAKE LEFT / RIGHT

NOTES:

1. The Airbrake key must be mapped to “AIRBRAKE TOGGLE” (B by default) and will act as a toggle switch.
2. I would personally not map anything to the flaps since they will be set in AUTO mode most of the time.

# WHAT YOU NEED MAPPED

ECM DISPENSE RIGHT: ALL  
(Grey button on RHS)

- ↑ TRIM PITCH UP
- TRIM BANK LEFT
- ↓ TRIM PITCH DOWN
- ← TRIM BANK RIGHT

- ↑ A/A Mode FWD: Sidewinder (Boresight)
- A/A Mode DOWN: Gun
- ↓ A/A Mode AFT: Sidewinder (SEAM)
- ←

Bomb Pickle

- ↑ ZOOM IN SLOW
- TDC DOWN (ACTION)
- ↓ ZOOM OUT SLOW
- ← CAGE/UNCAGE (MAVERICK)

Trigger: Fire Gun/Launch Sidewinder, Sidearm

- ↑ Sensor Sel. FWD: INS, IRMV/EOMV
- Sensor Sel. RIGHT: FLIR/HUD-BH/WH
- ↓ Sensor Sel. AFT: DMT LST/TV
- ← Sensor Sel. LEFT: MAP Center/Decenter
- P Sensor Sel. DOWN: HUD Reject

- ↑ COMM FWD: Select COMM 1
- 
- ↓ COMM AFT: Select COMM 2
- ←

AG Target Undesignate/NWS/FOV Toggle

WP Increment

- ←
- AIRBRAKE TOGGLE (B)

Emergency SAAHS Disconnect

- ↑ TDC FORWARD
- TDC RIGHT
- ↓ TDC AFT
- ← TDC LEFT

- ← ECM DISPENSE AFT: CHAFF
- ECM DISPENSE FWD: FLARES

+ TOE BRAKES (MAPPED ON PEDALS)



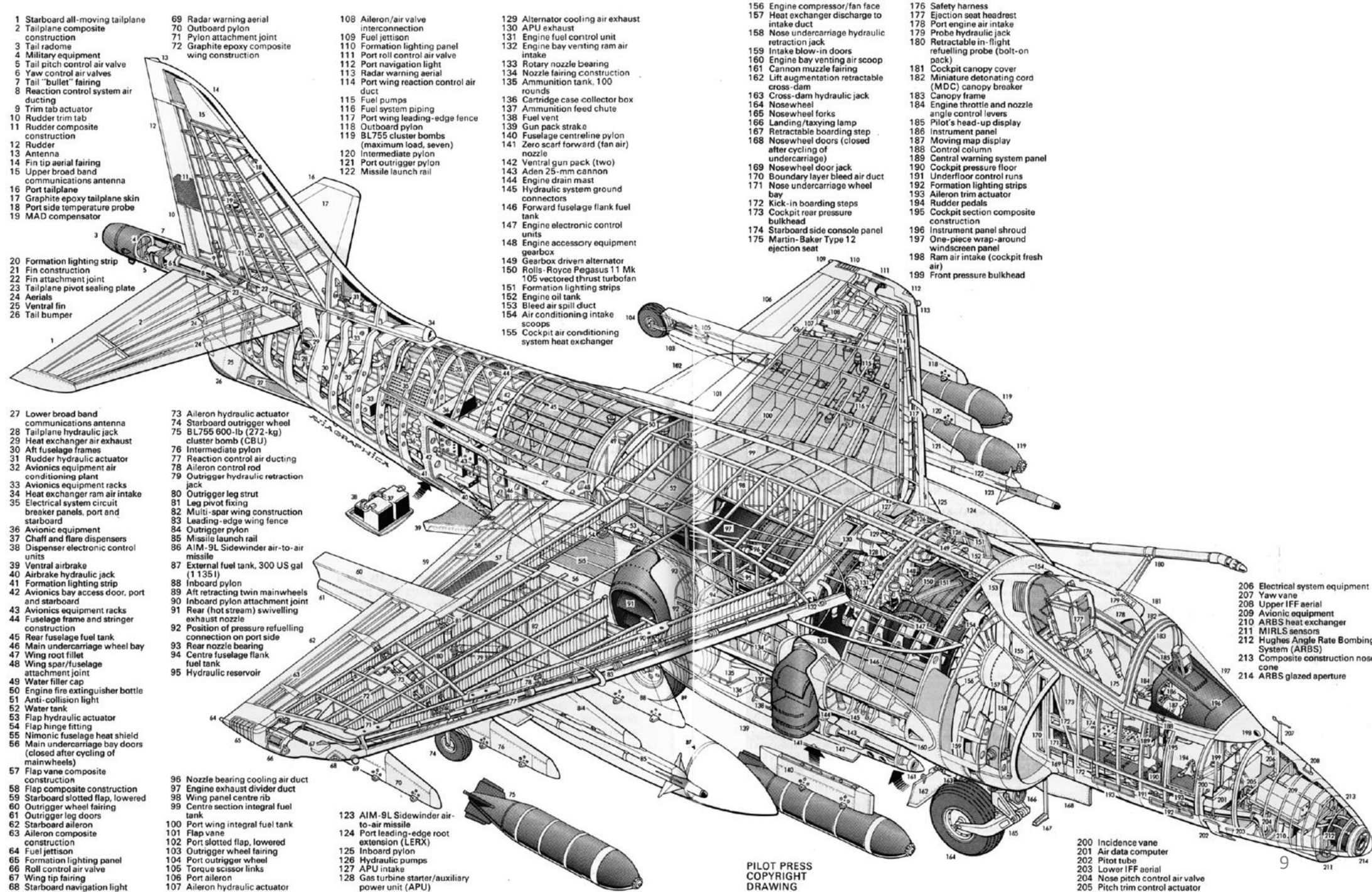

- 1 Starboard all-moving tailplane
- 2 Tailplane composite construction
- 3 Tail radome
- 4 Military equipment
- 5 Tail pitch control air valve
- 6 Yaw control air valves
- 7 Tail "bullet" fairing
- 8 Reaction control system air ducting
- 9 Trim tab actuator
- 10 Rudder trim tab
- 11 Rudder composite construction
- 12 Rudder
- 13 Antenna
- 14 Fin tip aerial fairing
- 15 Upper broad band communications antenna
- 16 Port tailplane
- 17 Graphite epoxy tailplane skin
- 18 Port side temperature probe
- 19 MAD compensator

- 20 Formation lighting strip
- 21 Fin construction
- 22 Fin attachment joint
- 23 Tailplane pivot sealing plate
- 24 Aerials
- 25 Ventral fin
- 26 Tail bumper

- 27 Lower broad band communications antenna
- 28 Tailplane hydraulic jack
- 29 Heat exchanger air exhaust
- 30 Aft fuselage frames
- 31 Rudder hydraulic actuator
- 32 Avionics equipment air conditioning plant
- 33 Avionics equipment racks
- 34 Heat exchanger ram air intake
- 35 Electrical system circuit breaker panels, port and starboard
- 36 Avionic equipment
- 37 Chaff and flare dispensers
- 38 Dispenser electronic control units
- 39 Ventral airbrake
- 40 Airbrake hydraulic jack
- 41 Formation lighting strip
- 42 Avionics bay access door, port and starboard
- 43 Avionics equipment racks
- 44 Fuselage frame and stringer construction
- 45 Rear fuselage fuel tank
- 46 Main undercarriage wheel bay
- 47 Wing root fillet
- 48 Wing spar/fuselage attachment joint
- 49 Water filler cap
- 50 Engine fire extinguisher bottle
- 51 Anti-collision light
- 52 Water tank
- 53 Flap hydraulic actuator
- 54 Flap hinge fitting
- 55 Nimonic fuselage heat shield
- 56 Main undercarriage bay doors (closed after cycling of mainwheels)
- 57 Flap vane composite construction
- 58 Flap composite construction
- 59 Starboard slotted flap, lowered
- 60 Outrigger wheel fairing
- 61 Outrigger leg doors
- 62 Starboard aileron
- 63 Aileron composite construction
- 64 Fuel jettison
- 65 Formation lighting panel
- 66 Roll control air valve
- 67 Wing tip fairing
- 68 Starboard navigation light

- 73 Aileron hydraulic actuator
- 74 Starboard outrigger wheel
- 75 BL755 600-lb (272-kg) cluster bomb (CBU)
- 76 Intermediate pylon
- 77 Reaction control air ducting
- 78 Aileron control rod
- 79 Outrigger hydraulic retraction jack
- 80 Outrigger leg strut
- 81 Leg pivot fixing
- 82 Multi-spar wing construction
- 83 Leading-edge wing fence
- 84 Outrigger pylon
- 85 Missile launch rail
- 86 AIM-9L Sidewinder air-to-air missile
- 87 External fuel tank, 300 US gal (1 135 l)
- 88 Inboard pylon
- 89 Aft retracting twin mainwheels
- 90 Inboard pylon attachment joint
- 91 Rear (hot stream) swivelling exhaust nozzle
- 92 Position of pressure refuelling connection on port side
- 93 Rear nozzle bearing
- 94 Centre fuselage flank fuel tank
- 95 Hydraulic reservoir
- 96 Nozzle bearing cooling air duct
- 97 Engine exhaust divider duct
- 98 Wing panel centre rib
- 99 Centre section integral fuel tank
- 100 Port wing integral fuel tank
- 101 Flap vane
- 102 Port slotted flap, lowered
- 103 Outrigger wheel fairing
- 104 Port outrigger wheel
- 105 Torque scissor links
- 106 Port aileron
- 107 Aileron hydraulic actuator

- 123 AIM-9L Sidewinder air-to-air missile
- 124 Port leading-edge root extension (LERX)
- 125 Inboard pylon
- 126 Hydraulic pumps
- 127 APU intake
- 128 Gas turbine starter/auxiliary power unit (APU)

- 108 Aileron/air valve interconnection
- 109 Fuel jettison
- 110 Formation lighting panel
- 111 Port roll control air valve
- 112 Port navigation light
- 113 Radar warning aerial
- 114 Port wing reaction control air duct
- 115 Fuel pumps
- 116 Fuel system piping
- 117 Port wing leading-edge fence
- 118 Outboard pylon
- 119 BL755 cluster bombs (maximum load, seven)
- 120 Intermediate pylon
- 121 Port outrigger pylon
- 122 Missile launch rail

- 129 Alternator cooling air exhaust
- 130 APU exhaust
- 131 Engine fuel control unit
- 132 Engine bay venting ram air intake
- 133 Rotary nozzle bearing
- 134 Nozzle fairing construction
- 135 Ammunition tank, 100 rounds
- 136 Cartridge case collector box
- 137 Ammunition feed chute
- 138 Fuel vent
- 139 Gun pack strake
- 140 Fuselage centreline pylon
- 141 Zero scarf forward (fan air) nozzle
- 142 Ventral gun pack (two)
- 143 Aden 25-mm cannon
- 144 Engine drain mast
- 145 Hydraulic system ground connectors
- 146 Forward fuselage flank fuel tank
- 147 Engine electronic control units
- 148 Engine accessory equipment gearbox
- 149 Gearbox driven alternator
- 150 Rolls-Royce Pegasus 11 Mk 105 vectored thrust turbofan
- 151 Formation lighting strips
- 152 Engine oil tank
- 153 Bleed air spill duct
- 154 Air conditioning intake scoops
- 155 Cockpit air conditioning system heat exchanger

- 156 Engine compressor/fan face
- 157 Heat exchanger discharge to intake duct
- 158 Nose undercarriage hydraulic retraction jack
- 159 Intake blow-in doors
- 160 Engine bay venting air scoop
- 161 Cannon muzzle fairing
- 162 Lift augmentation retractable cross-dam
- 163 Cross-dam hydraulic jack
- 164 Nosewheel
- 165 Nosewheel forks
- 166 Landing/taxying lamp
- 167 Retractable boarding step
- 168 Nosewheel doors (closed after cycling of undercarriage)
- 169 Nosewheel door jack
- 170 Boundary layer bleed air duct
- 171 Nose undercarriage wheel connectors
- 172 Kick-in boarding steps
- 173 Cockpit rear pressure bulkhead
- 174 Starboard side console panel
- 175 Martin-Baker Type 12 ejection seat

- 176 Safety harness
- 177 Ejection seat headrest
- 178 Port engine air intake
- 179 Probe hydraulic jack
- 180 Retractable in-flight refuelling probe (bolt-on pack)
- 181 Cockpit canopy cover
- 182 Miniature detonating cord (MDC) canopy breaker
- 183 Canopy frame
- 184 Engine throttle and nozzle angle control levers
- 185 Pilot's head-up display
- 186 Instrument panel
- 187 Moving map display
- 188 Control column
- 189 Central warning system panel
- 190 Cockpit pressure floor
- 191 Underfloor control runs
- 192 Formation lighting strips
- 193 Aileron trim actuator
- 194 Rudder pedals
- 195 Cockpit section composite construction
- 196 Instrument panel shroud
- 197 One-piece wrap-around windscreen panel
- 198 Ram air intake (cockpit fresh air)
- 199 Front pressure bulkhead

- 206 Electrical system equipment
- 207 Yaw vane
- 208 Upper IFF aerial
- 209 Avionic equipment
- 210 ARBS heat exchanger
- 211 MIRLS sensors
- 212 Hughes Angle Rate Bombing System (ARBS)
- 213 Composite construction nose cone
- 214 ARBS glazed aperture

- 200 Incidence vane
- 201 Air data computer
- 202 Pitot tube
- 203 Lower IFF aerial
- 204 Nose pitch control air valve
- 205 Pitch trim control actuator

PILOT PRESS  
COPYRIGHT  
DRAWING

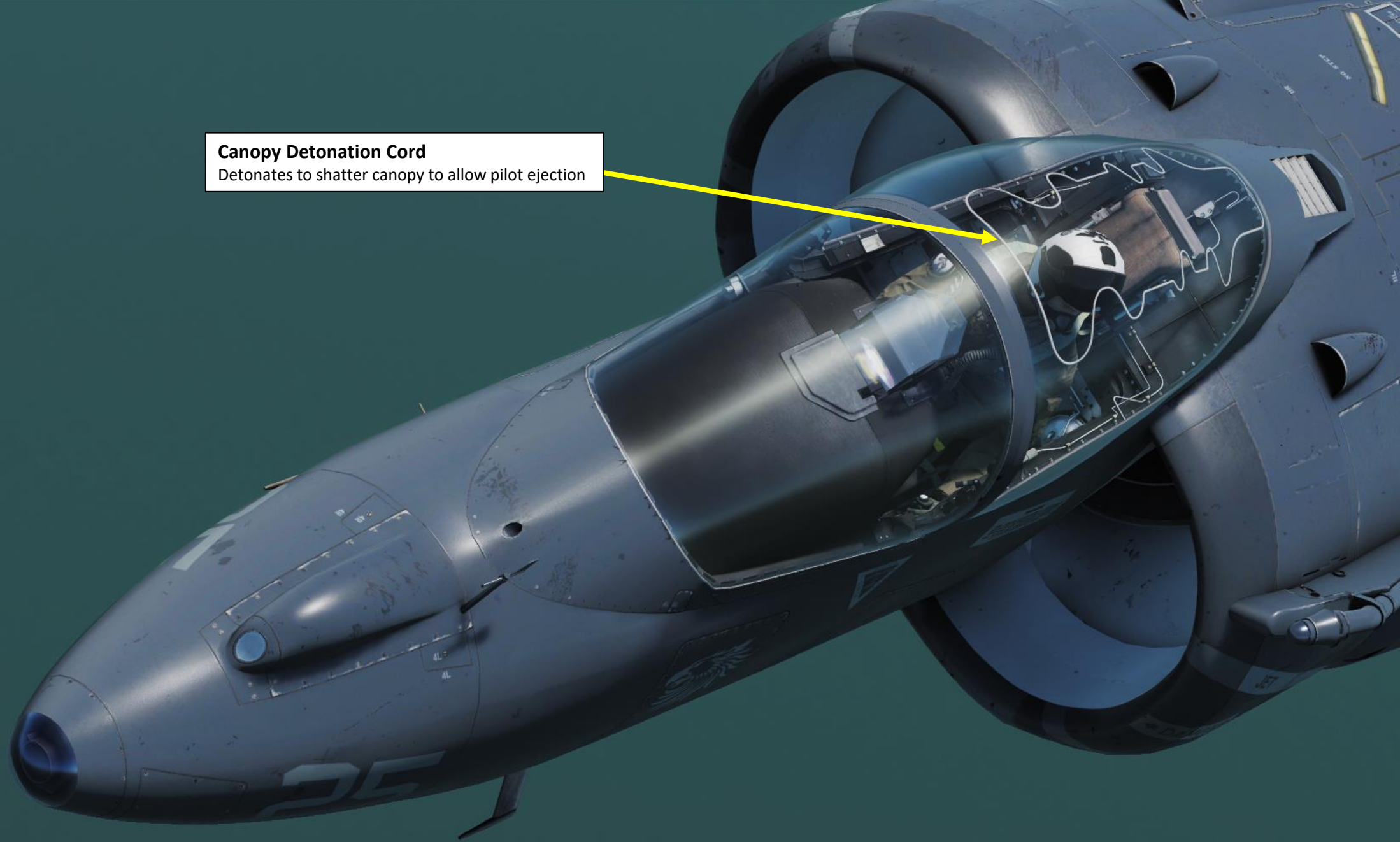

**Canopy Detonation Cord**  
Detonates to shatter canopy to allow pilot ejection

## PART 3 – COCKPIT & GAUGES

AV-8B  
HARRIER II



Tip: Pilot body can be toggled ON/OFF with "RSHIFT+P"

AV-8B  
HARRIER II

**PART 3 - COCKPIT & GAUGES**



**DECS (Digital Engine Control System) Switch**

UP = ON  
DOWN = OFF

**Fuel Shutoff Lever**

UP = OFF (Fuel Valve Closed)  
DOWN = ON (Fuel Valve Open)  
*NOTE: The Fuel Lever will automatically lock in the DOWN position. To unlock the lever, use the "LWIN+F" key binding.*

**Fuel Shutoff Lever Lock Release Button**

Key Binding: LWin + F

**LIDS (Lift Improvement Devices System) Switch**

AFT = NORMAL  
FWD = RETRACT

**Oxygen Switch**

AFT = OFF  
FWD = ON

**Engine RPM Selector Switch**

AFT = LOW  
FWD = HIGH

*Note: Selector switch will make the engine tachometer display either the low-pressure compressor speed (HIGH speed) or the bypass fan speed (LOW speed)*

**EFC (Engine Fuel Control) Switch**

AFT = POS 2 (DECU 2)  
FWD = POS 1 (DECU 1)

*NOTE: This switch selects which engine DECU (Digital Engine Control Unit) is used to control fuel flow and engine parameters, as there are two DECUs available for redundancy.*

**Water Tank Dump Switch**

DUMP: Dumps contents of water injection tank  
OFF: Normal Operation

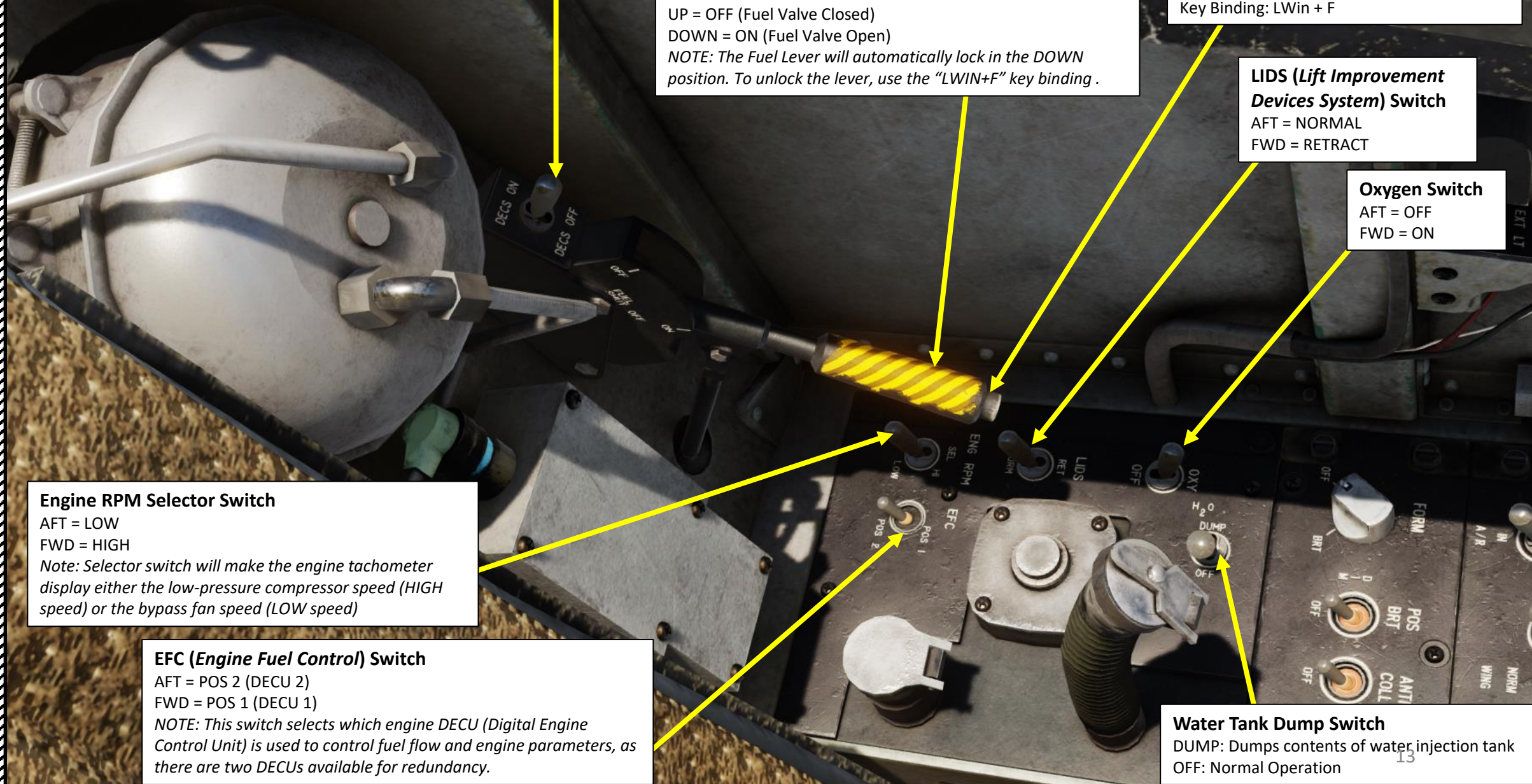

**Air Refueling (A/R) Probe Switch**  
AFT = FUEL PROBE IN/RETRACTED  
MIDDLE = FUEL PROBE OUT/EXTENDED  
FWD = Leaves probe extended and pressurizes fuel tank (no fuel transfer)

**Formation Lights Brightness Knob**  
OFF / BRIGHT

**Position Lights Switch**  
AFT = OFF  
FWD = BRIGHT

**Anti-collision Lights Switch**  
AFT = OFF  
FWD = BRIGHT

**Auxiliary Lights Switch**  
AFT = OFF  
FWD = BRIGHT

**Fuel Proportioner Switch**  
AFT = OFF  
FWD = ON

**Throttle Friction Switch**

**Manual Fuel Switch**  
AFT = OFF  
FWD = ON

**Rudder Trim Switch**

**Fuel Booster Pump Switch (Left/Right)**  
AFT = DC OPERATED (use if pump is failed)  
MIDDLE = OFF  
FWD = NORMAL

**Wing Fuel Dump Switch (Left / Right)**  
AFT = OFF  
FWD = Dumps contents of selected fuel tank

**Flood Lamps**  
Scroll mousewheel to change orientation



**SEAT CHECKLIST**  
REMOVE THREE SAFETY PINS  
EMER RELEASE HANDLE DN & LKD  
PERSONAL SERVICES CONNECTED  
LH & RH RISERS CONNECTED  
LH & RH LAP BELTS CONNECTED  
GROUND SAFETY DEVICE DN & LKD

**EMERGENCY HANDLE**  
CANOPY FRACTURE  
ROTATE UP TO RELEASE  
PULL TO FIRE

**Seat Adjustment Switch**



**External Lights Master Switch**  
AFT = OFF  
MIDDLE = NVG (Night Vision Goggles)  
FWD = NORMAL



### Seat Checklist

- Remove three safety pins
- Emergency release handle down & locked
- Personal services connected
- Left hand & right hand risers connected
- Left hand & right hand lap belts connected
- Ground safety device on & locked

### Emergency Handle – Canopy Fracture

- Rotate up to release
- Pull to fire

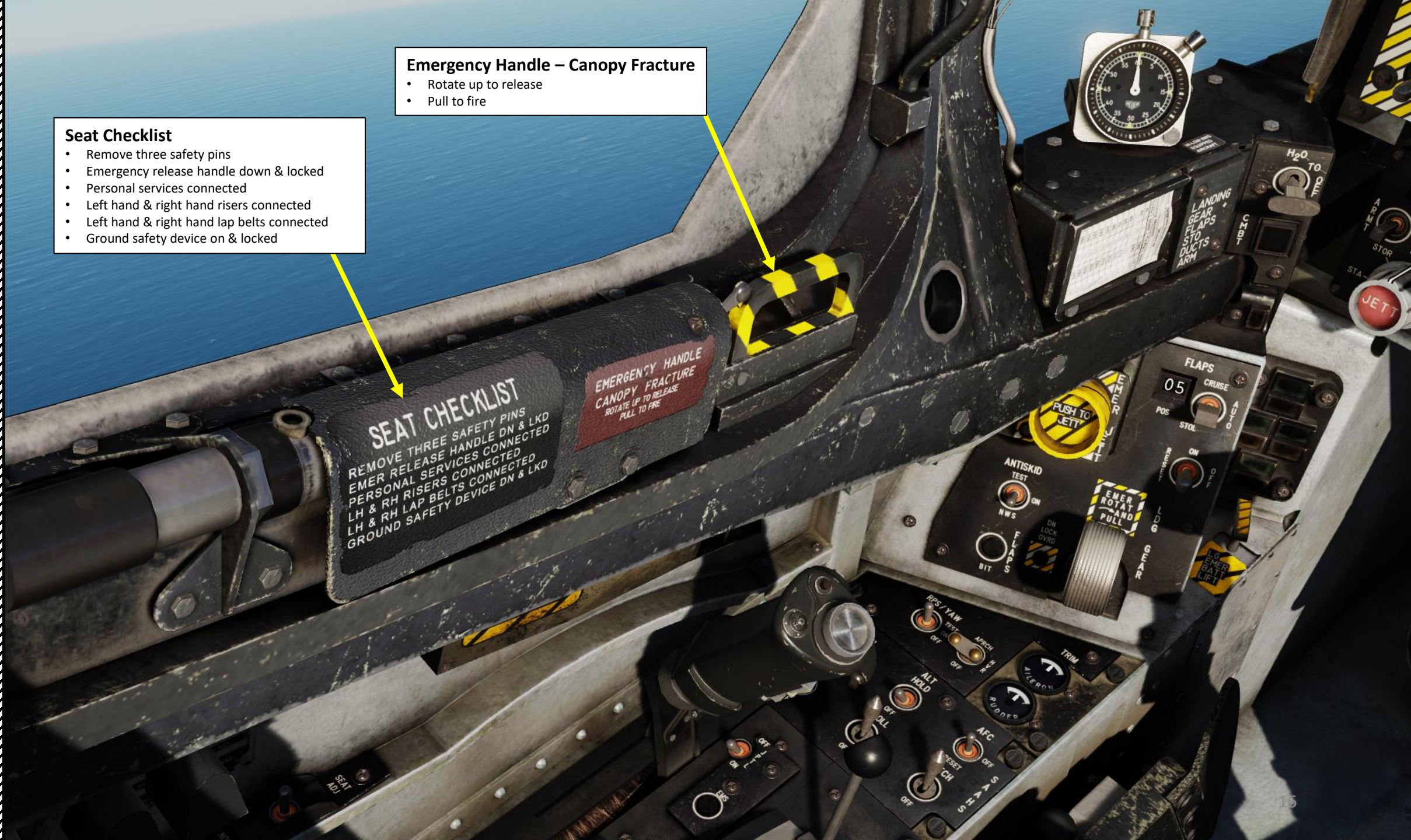

Throttle

**JPTL (Jet Pipe Temperature Limiter) Button**  
AFT = ON  
FWD = OFF

**EMS (Engine Monitoring System) Pilot Record Button**  
When depressed, EMU (Engine Monitoring Unit) records engine parameters, which will be available for the ground maintenance crews after flight.

**STO (Short Takeoff & Landing) Stop Lever**  
Blocks Nozzle Angle Lever to selected position

**Nozzle Angle Control Lever Friction Knob**

**Nozzle Angle Control Lever**  
Controls angle of engine nozzles

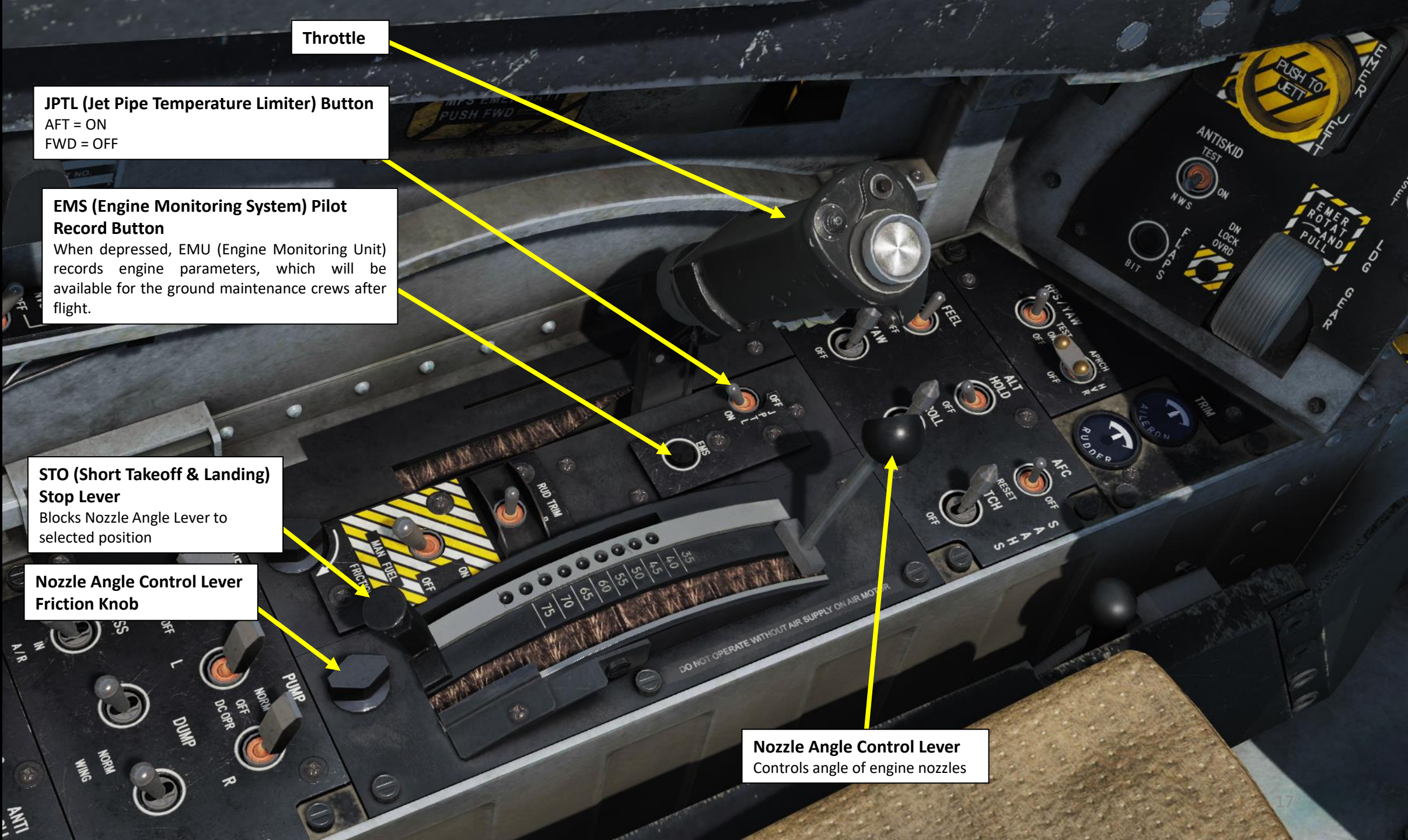

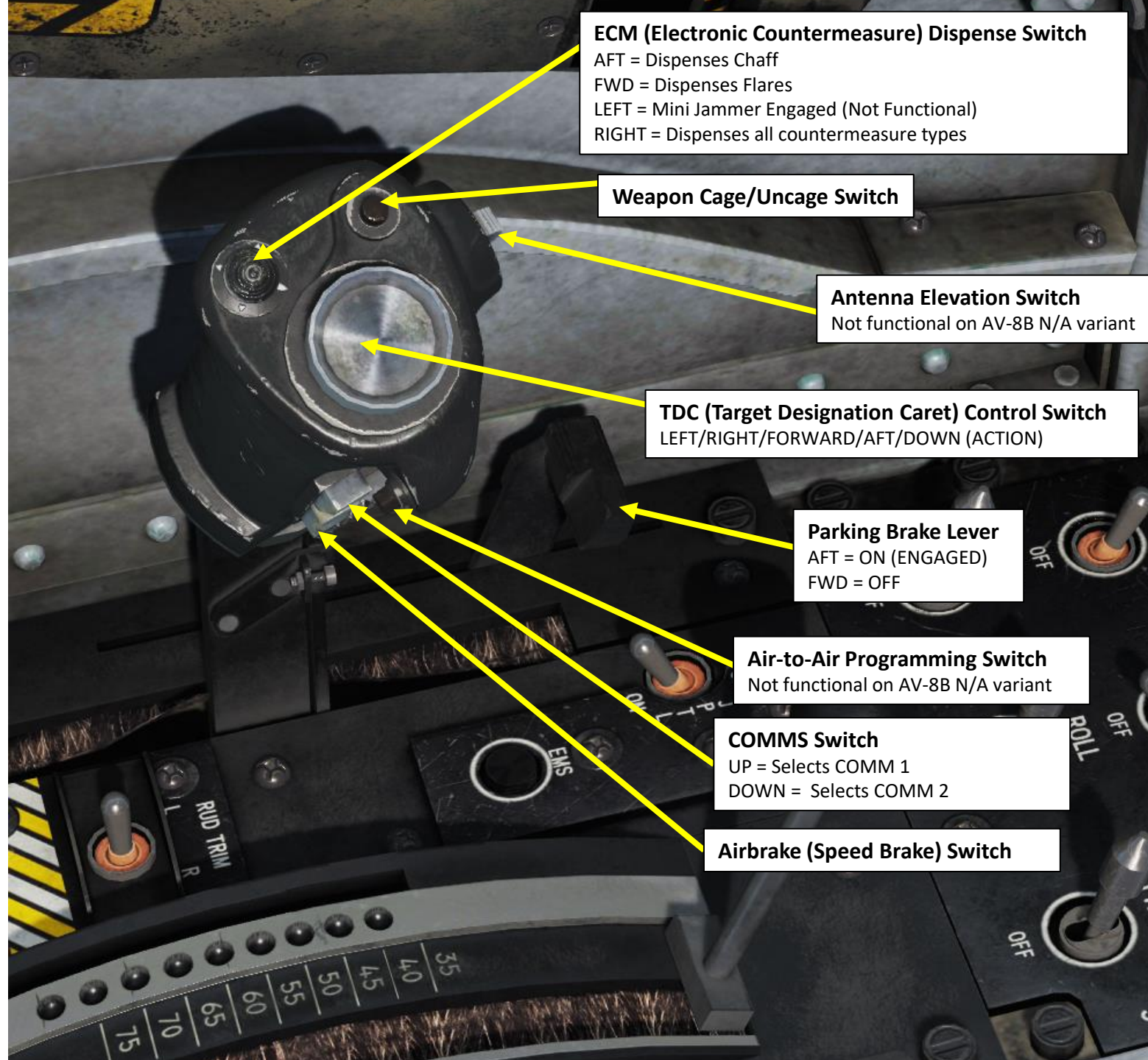

**ECM (Electronic Countermeasure) Dispense Switch**  
AFT = Dispenses Chaff  
FWD = Dispenses Flares  
LEFT = Mini Jammer Engaged (Not Functional)  
RIGHT = Dispenses all countermeasure types

**Weapon Cage/Uncage Switch**

**Antenna Elevation Switch**  
Not functional on AV-8B N/A variant

**TDC (Target Designation Caret) Control Switch**  
LEFT/RIGHT/FORWARD/AFT/DOWN (ACTION)

**Parking Brake Lever**  
AFT = ON (ENGAGED)  
FWD = OFF

**Air-to-Air Programming Switch**  
Not functional on AV-8B N/A variant

**COMMS Switch**  
UP = Selects COMM 1  
DOWN = Selects COMM 2

**Airbrake (Speed Brake) Switch**



**Throttle Cutoff Lever**  
Only clickable when  
throttle is at IDLE

**Yaw Stability Augmentation System Switch**  
AFT = OFF  
FWD = ON

**Q-Feel Unit Switch**  
AFT = OFF  
FWD = ON  
*Note: Since the Harrier's aircraft control surfaces are hydraulically-actuated, stick force is not felt by the pilot unless an artificial force feedback system, or "Q-Feel" system gives the pilot a force feedback based on the aircraft's airspeed, or "q", which is the dynamic pressure of the aircraft.*

**RPS (Rudder Pedal Shakers)/YAW Switch**  
AFT = OFF, RPS disabled  
MIDDLE = ON, RPS enabled  
FWD = TEST

**SAAHS:  
STABILITY AUGMENTATION & ATTITUDE HOLD SYSTEM**

**Landing/Taxi Lights Switch**  
AFT = OFF  
MIDDLE = HOVER  
FWD = APPROACH

**SAAHS Altitude Hold Mode Switch**  
AFT = OFF  
FWD = ON (ENGAGED)

**Roll Stability Augmentation System Switch**  
AFT = OFF  
FWD = ON

**Pitch Stability Augmentation System Switch**  
AFT = OFF  
FWD = ON

**SAAHS AFC (Automatic Flight Controls) Mode Switch**  
AFT = RESET  
MIDDLE = OFF  
FWD = ON

**Aileron Trim Indicator**

**Rudder Trim Indicator**

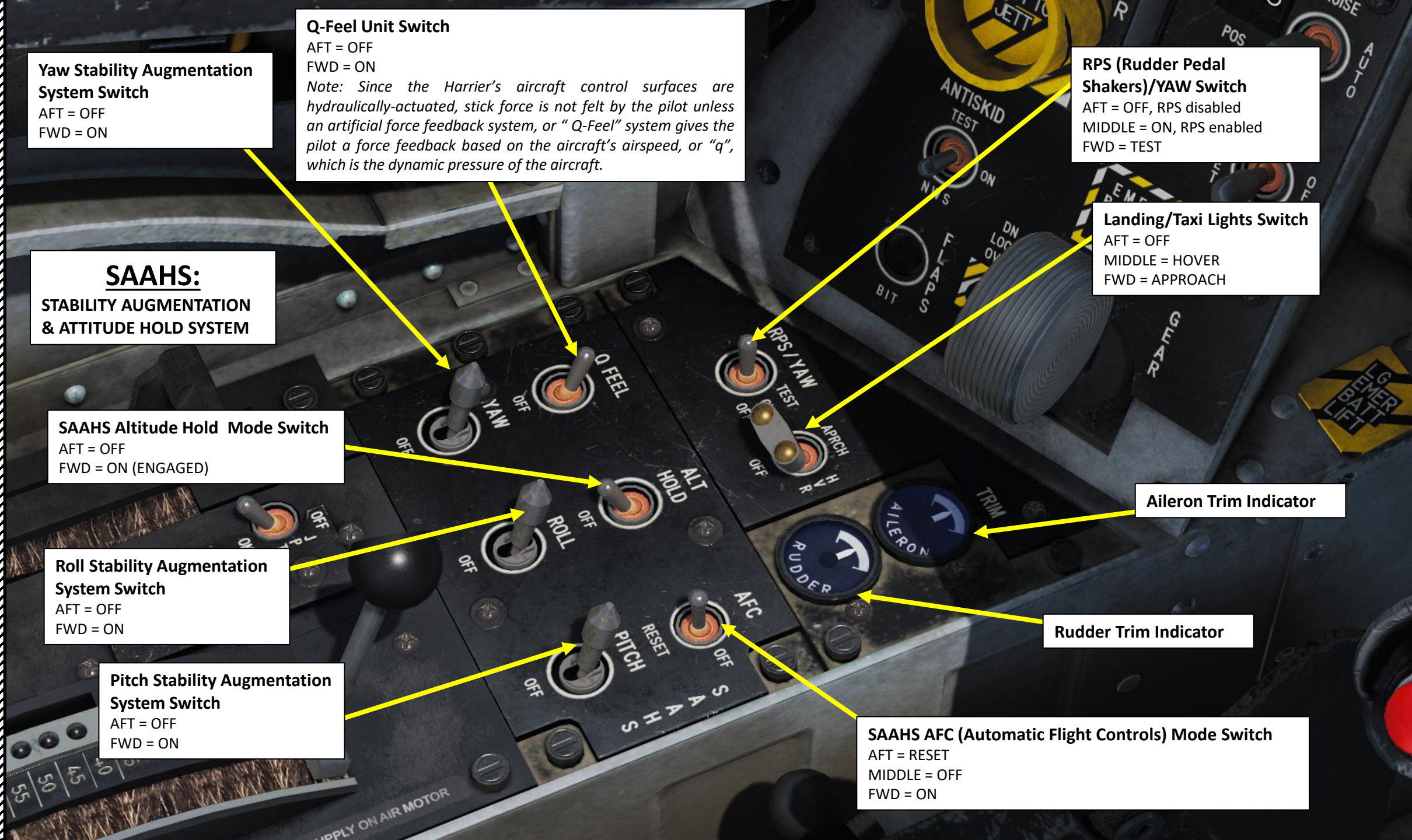

Magnetic Azimuth Detector Table



Flaps Position Angle (degrees)



Emergency Jettison Button



**Landing Gear Position Indicator**  
GREEN = Deployed  
AMBER = In Transition  
EXTINGUISHED = Up & Locked  
Note: **M** is for Main Landing Gear, **N** is for Nose Landing Gear, **L** is for Left Wing and **R** is for Right Wing Landing Gear

**Anti-skid Switch**  
UP = TEST  
MIDDLE = ON  
DOWN = Nosewheel Steering



**Flaps Mode Switch**  
UP = Cruise Mode  
MIDDLE = Automatic Mode  
DOWN = STOL (Short Takeoff & Landing) Mode

Flaps BIT (Built-In Test) Button



**Landing Gear Emergency Battery Lever**  
DOWN = OFF  
UP = ON

Landing Gear Down Lock Override Button



**Flaps Power Switch**  
LEFT = RESET  
MIDDLE = ON  
RIGHT = OFF

**Landing Gear Lever**  
DOWN = Gear Extended  
UP = Gear Retracted



System: Magnetic Azimuth Detector			
To Fly	Steer	To Fly	Steer
N	0	180	180
15	15	195	195
30	30	210	210
45	45	225	225
60	60	240	240
75	75	255	255
90	90	270	270
105	105	285	285
120	120	300	300
135	135	315	315
150	150	330	330
165	165	345	345



Clock

**Water Injection Switch**  
 UP = Takeoff Mode  
 MIDDLE = OFF  
 DOWN = Landing Mode

**CMBT (Combat Thrust) Activated Indicator**  
 Flashes after 2.5 minutes of CMBT usage

**Armament Delivery Mode**

AUT: Automatic  
 CIP: CCIP, Continuously Computed Impact Point  
 DSL: Depressed Sight Line  
 DIR: Direct

**Fuzing Control**

**Weapon Quantity Control**

**Weapon Multiple Control**

**Weapon Interval Control**

**Weapon Manual Control**

NORM: Normal  
 N/T: Nose & Tail Fuzing  
 N: Nose Fuzing  
 T: Tail Fuzing

**ASCM (Armament Stores Management Control Indicator) Panel**

**IR (Infrared) Cooling Switch**

Applies manual cooling to all sidewinder-equipped stations. You shouldn't be turning it on at all unless you have a system failure that prevents the sidewinder seeker head from cooling or need to cool sidewinder's while on the ground for preflight checks.

**Station Selection Button & Indication**

**Selective Jettison Control**

STA: Selected stations  
 STOR: Selected stores  
 SAFE: Safety Position  
 CMBT: Combat  
 FUEL: External Fuel Tanks  
 PUSHBUTTON: Jettisons selected ordnance

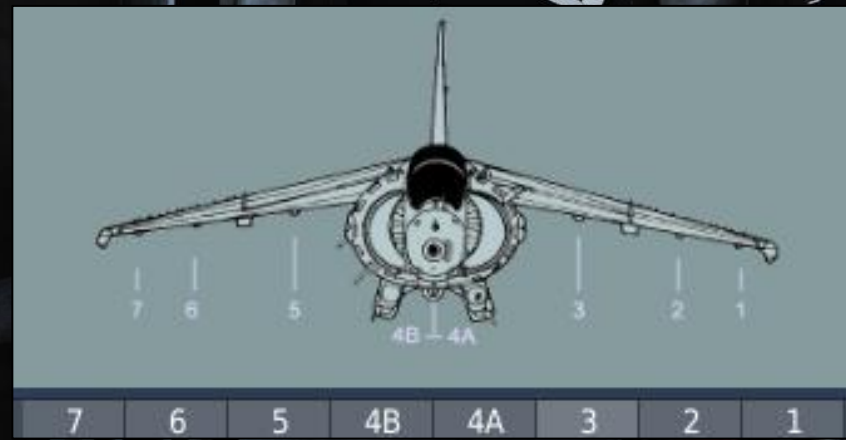

**Standby Magnetic Compass**

Whiskey compass is used as a backup

**Navigation Master Mode Button**

(HUD, Heads-Up Display mode)

**Air-to-Ground Master Mode Button**

(HUD, Heads-Up Display mode)

**Flood Lamps**

Scroll mousewheel to change orientation

**Canopy Handle**

Key Binding: LCTRL+R

**Flare Salvo Button**

**VSTOL (Vertical Short Takeoff & Landing)**

Master Mode Button

(HUD, Heads-Up Display mode)

**Master Arm Switch**

UP = ON  
DOWN = OFF

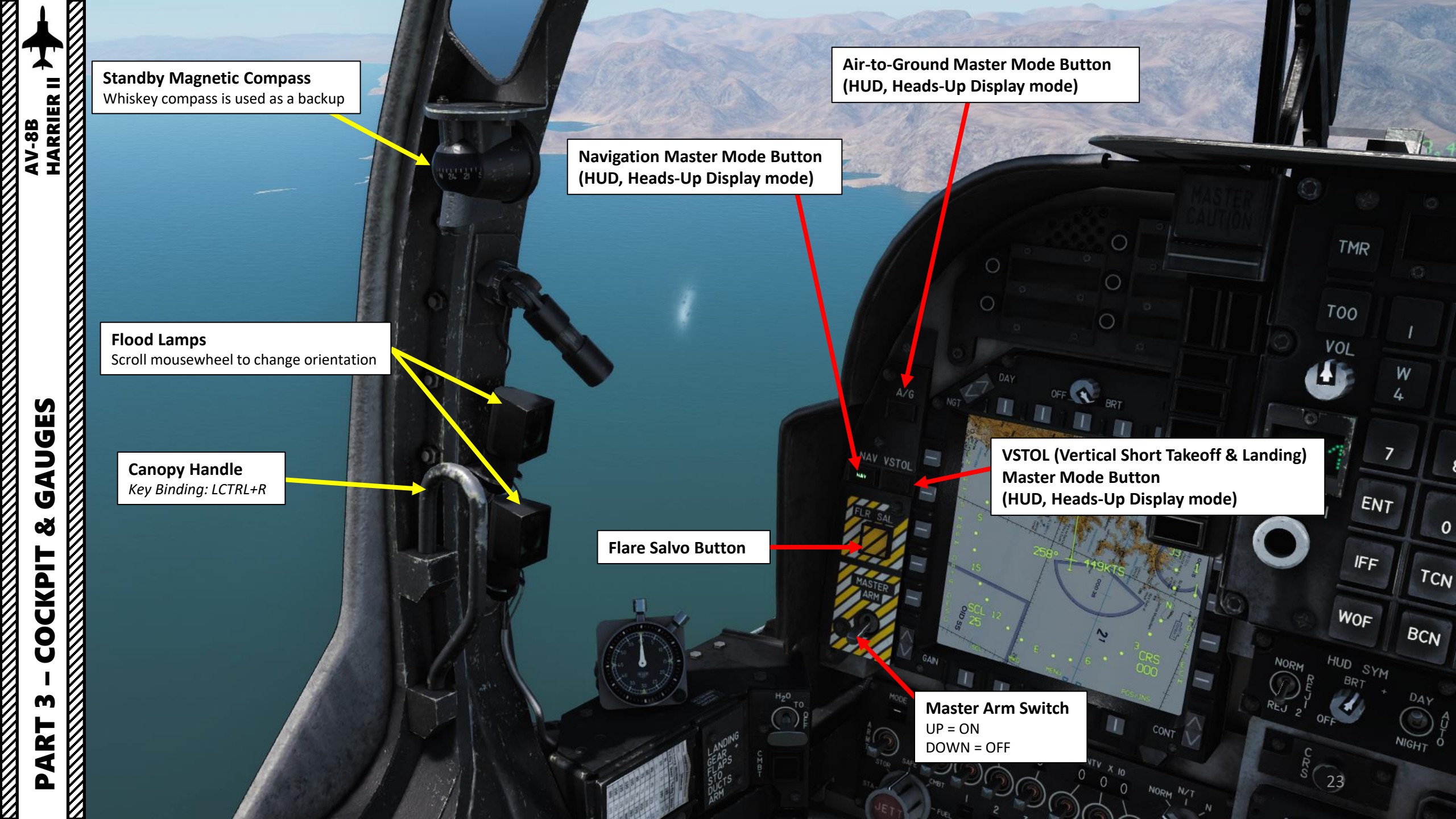

ODU (Option Display Unit)  
Option 1 Button & Indication

ODU (Option Display Unit)  
Option 2 Button & Indication

ODU (Option Display Unit)  
Option 3 Button & Indication

ODU (Option Display Unit)  
Option 4 Button & Indication

ODU (Option Display Unit)  
Option 5 Button & Indication



MODE FUZ QTY MULT INTV X 10 N/T N  
SA FE 0 0 0 0 0 0 0

MPCD (Multi-Purpose Color Displays)  
Mode Switch  
Day/Night



MPCD (Multi-Purpose Color Displays)  
Symbology Brightness Control



MPCD (Multi-Purpose Color Displays)  
Brightness Control



MPCD (Multi-Purpose Color Displays)  
Gain Control



MPCD (Multi-Purpose Color Displays)  
Contrast Control



NAV VSTOL

NAV

FLR SAL

MASTER ARM

MODE FUZ QTY MULT INTV X 10 NORM N/T N  
SA FE 0 0 0 0 0 0 0

NORM REJ 2

HUD SYM BRT + OFF

DAY NIGHT AUTO

VIDEO BRT

CRS

8 9 10 11 12

25 DI - VE

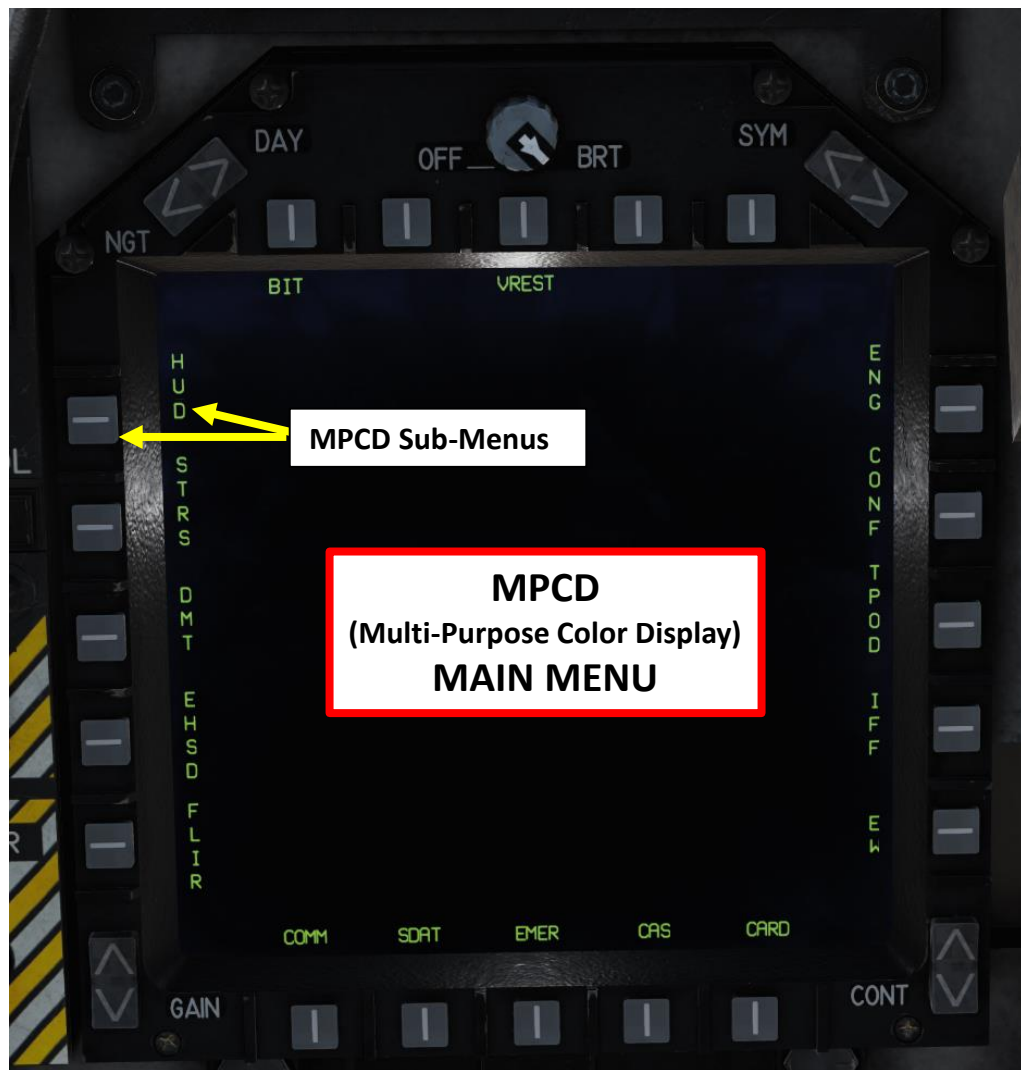

### MPCD Sub-Menus

- FLIR: NAVFLIR (Navigation Forward-Looking Infrared) Display
- EHSO: Electronic Horizontal Situation Display
- DMT: Dual Mode Tracker display
- STRS: Stores Page
- HUD: Heads-Up Display repeater
- BIT: Built-In Test page
- VRST: VSTOL-REST (Vertical & Short Takeoff & Landing) calculator page
- ENG: Engine parameters page
- CONF: Software configuration page
- TPOD: Targeting Pod (LITENING II) page. Blank if no TPOD is loaded.
- IFF: Identify-Friend-or-Foe Data page.
- EW: Electronic Countermeasures/Warfare page. Displays RWR (Radar Warning Receiver)
- CARD: Pre-programmed kneeboard card display page.
- CAS: Close Air Support page.
- EMER: Emergency Checklist Cards page.
- SDAT: System Data page.
- COMM: Communication data page.

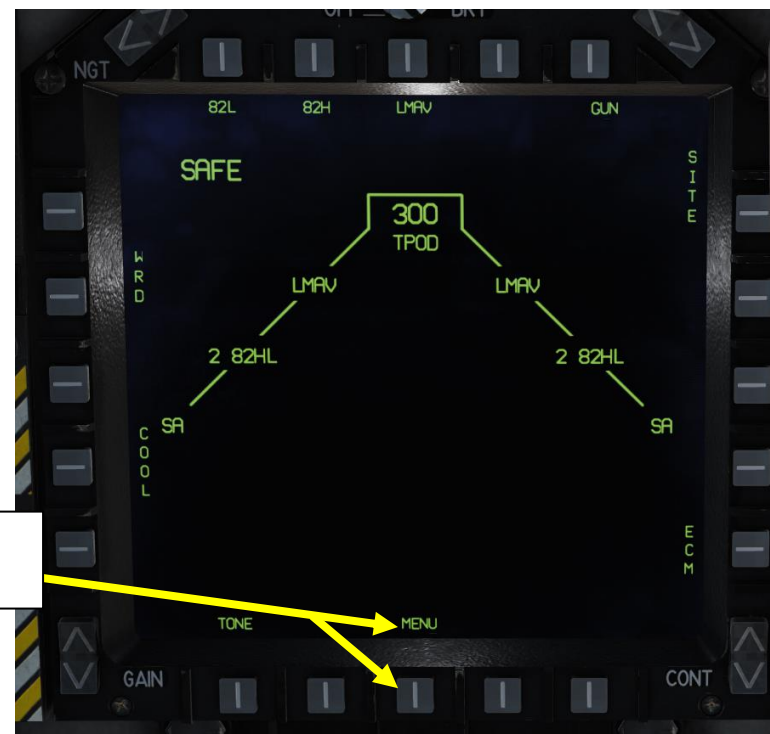

MPCD Main Menu Accessible from every page



MPCD  
FLIR MENU

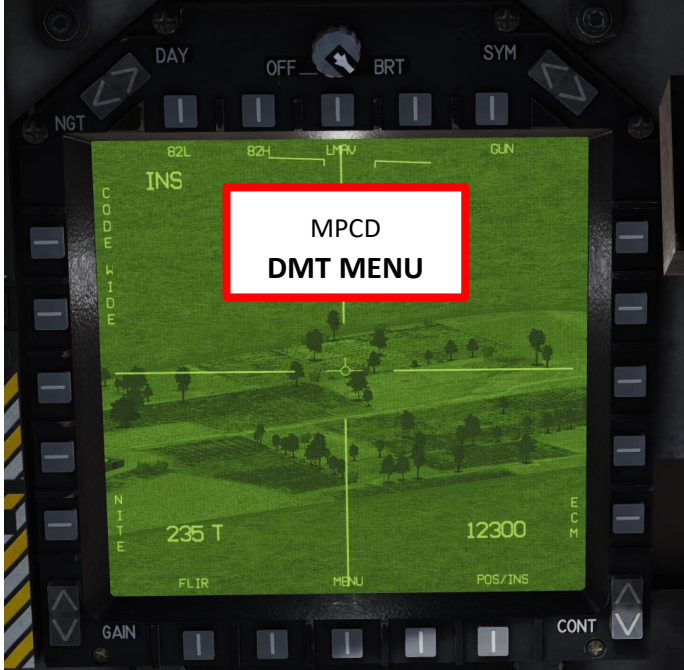

MPCD  
DMT MENU



MPCD  
STRS MENU



MPCD  
ENG MENU

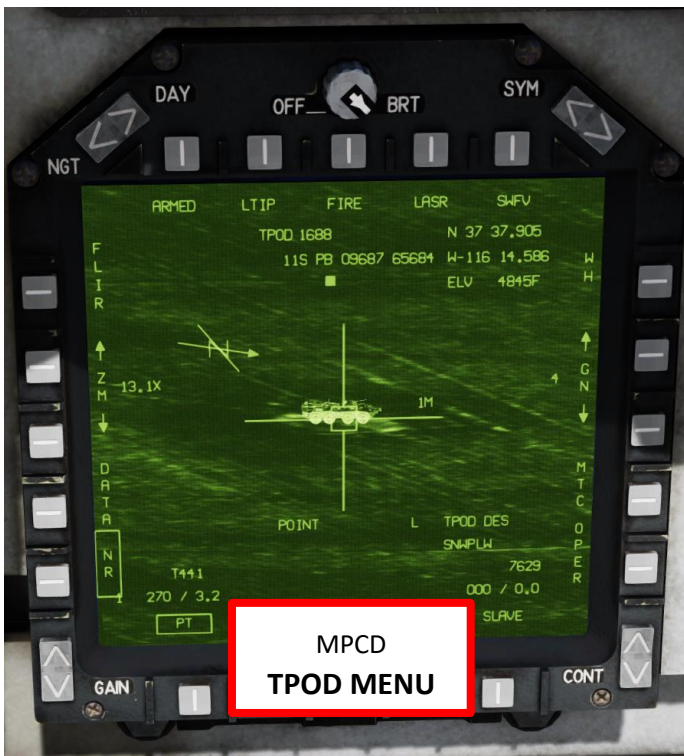

MPCD  
TPOD MENU



MPCD  
EW MENU





MPCD  
**EHSD (Electronic Horizontal Situation Display) MENU**

**TACAN Data**  
Bearing (degrees)      Distance (Nm)  
Time-to-Go to TACAN Station (minutes:seconds)

**Waypoint Data**  
Bearing (degrees)      Distance (Nm)  
Time-to-Go to Waypoint (minutes:seconds)

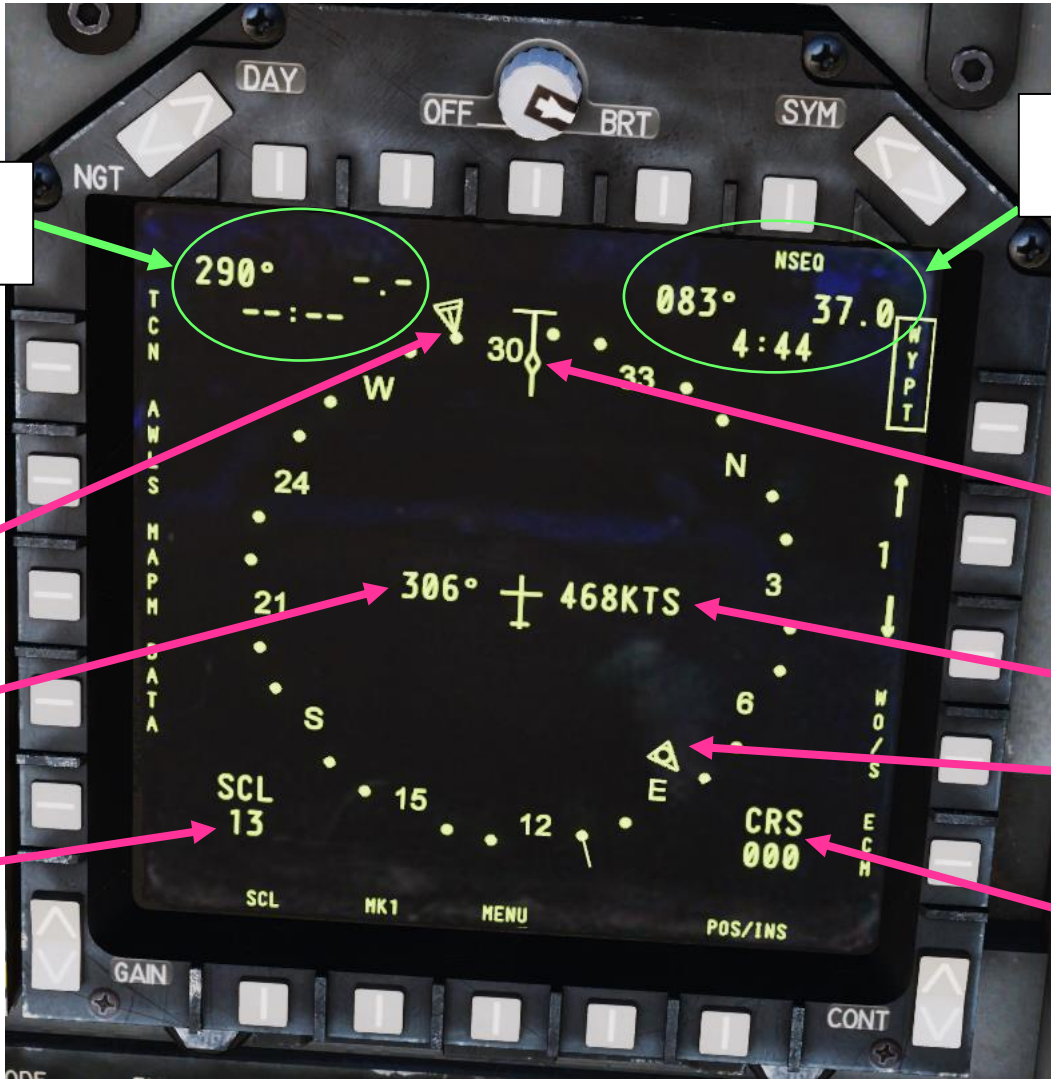

TACAN bearing pointer

Ground Track (deg)

EHSD Map Scale

Aircraft ground track pointer

Ground Speed (kts)

Waypoint Bearing Pointer

Selected Course

**RIGHT Refuel Light**

- Flashing: internal right wing tank or right external tank is full.
- Illuminated (steady): both right wing and right external tanks are full.

**READY Refuel Light**

- Illuminates when you are cleared for air-to-air refueling.
- Extinguishes during contact.

**LEFT Refuel Light**

- Flashing: internal left wing tank or left external tank is full.
- Illuminated (steady): both left wing and left external tanks are full.



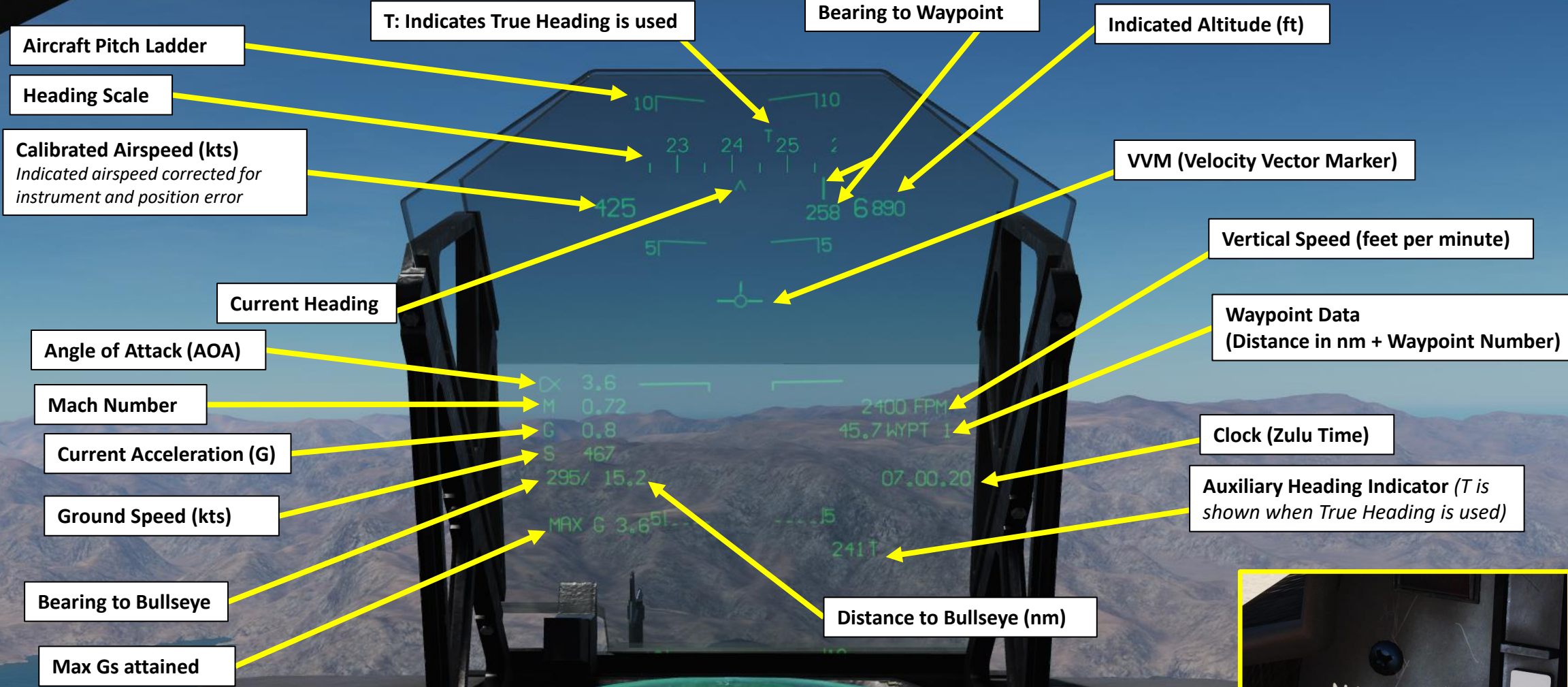

HEADS-UP DISPLAY (NAV MODE)



Angle of Attack (AoA)  
Analog Scale

Digital RPM (%)

Digital Jet Pipe Temperature  
(JPT) in deg C

Power Margin (J, JPT or R, RPM)  
and Water Flow Indication

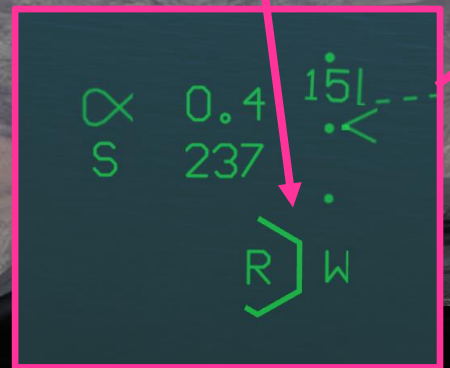

Depressed Attitude  
Symbol (Witch Hat)

Vertical Speed Analog Scale

Digital Nozzle Position Indicator  
in degrees (N)

Digital Flap Position Indicator  
in degrees (F)

Side Slip Indicator



HEADS-UP DISPLAY (VSTOL MODE)

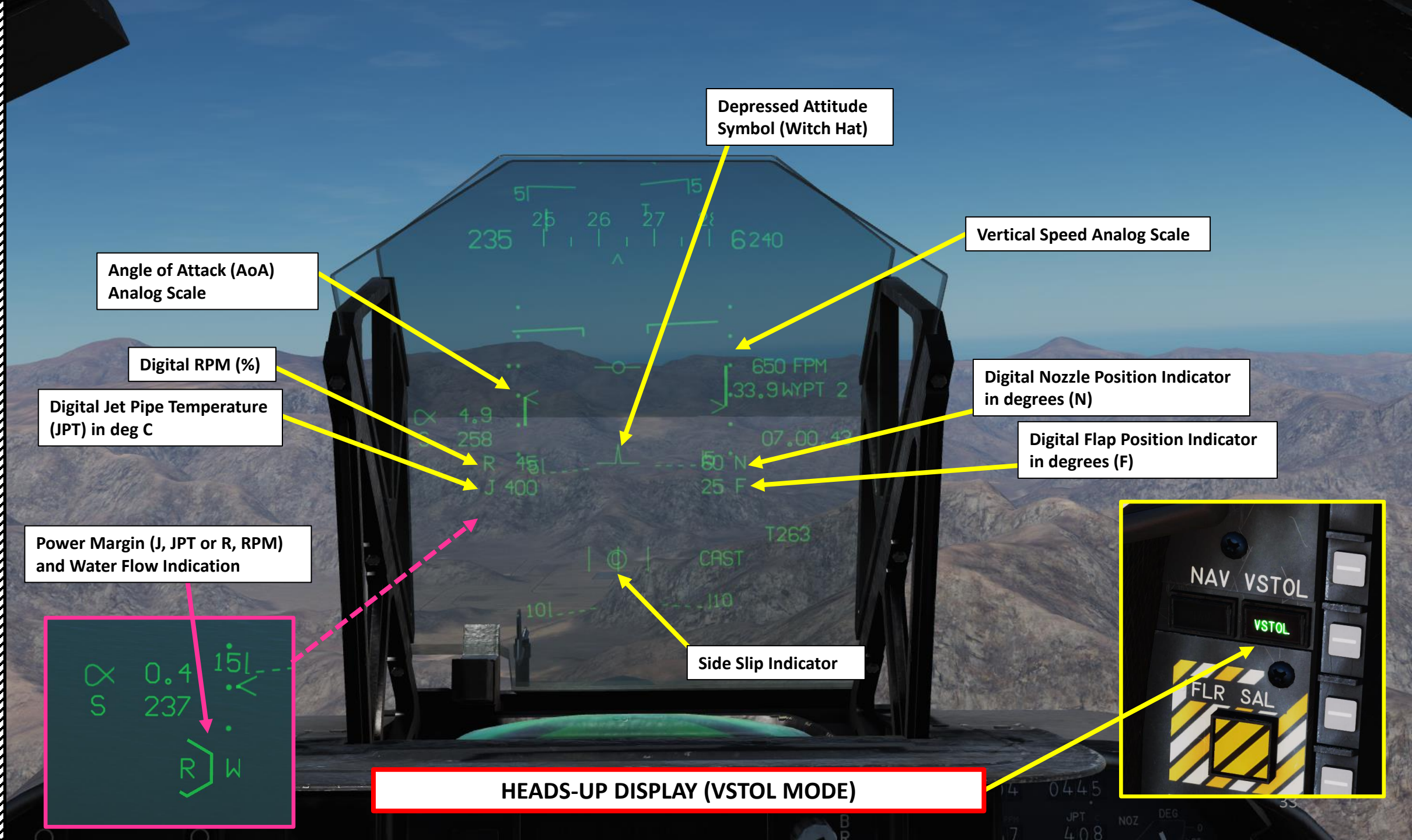

**UFC (Upfront Control) Display**  
Shown: COMM 1 Frequency

Keypad

Display Brightness Control

**Function Mode Keys**  
TMR: Timer  
TOO: Target-of-Opportunity

**COMM1 & COMM2 Radio UFC**

- Power/Volume Knob
- Radio Channel Display (M = Manual)
- Channel Selector (scroll mousewheel)

**Function Mode Keys**

ENT: Enter (validates & saves entered values)  
 IFF: Sets UFC for IFF system  
 TCN: Sets UFC for TACAN  
 AWL: Sets UFC for All Weather Landing System  
 WPN: Sets UFC for Weapons delivery programming  
 WOF: Waypoint Over Fly (INS position update)  
 BCN: Radar Beacon Identification System ON/OFF  
 ALT: Sets UFC to configure aircraft's altimeter  
 EM CON: Emission Control System ON/OFF

**Specialty Input Keys**

I/P: Identification-of-Position (used by IFF)  
 SVE: Save (not functional)

**Master Caution**  
Push to Reset

**Master Warning**  
Push to Reset

MASTER  
CAUTION

MASTER  
WARNING

**Warning Lights**

- **FIRE**: engine fire detected
- **LAW**: Low Altitude Warning
- **FLAPS**: Flap system failure
- **L TANK**: Left fuel tank system overpressure or overtemperature
- **R TANK**: Right fuel tank system overpressure or overtemperature
- **HYD**: Both HYD1 and HYD2 hydraulic systems are failed
- **GEAR**: Landing Gear unsafe/fails to extend.
- **OT**: Overtemperature (Engine JPT limits exceeded)
- **JPTL**: Jet Pipe Temperature Limiter control inoperative
- **EFC**: Engine Fuel Control boxes DECU1 and DECU2 are both failed
- **GEN**: AC generator is offline

**Caution Lights**

- **L FUEL**: left fuel system level is low (steady when less than 750 lbs, flashing when less than 250 lbs)
- **R FUEL**: right fuel system level is low (steady when less than 750 lbs, flashing when less than 250 lbs)
- **15 SEC**: JPT (Jet Pipe Temperature) above normal lift rating (flashes after 15 sec)
- **MFS**: Manual Fuel System ON
- **BINGO**: Fuel below bingo (return to base) setting
- **H<sub>2</sub>O**: Less than 15 seconds of water injection remaining.

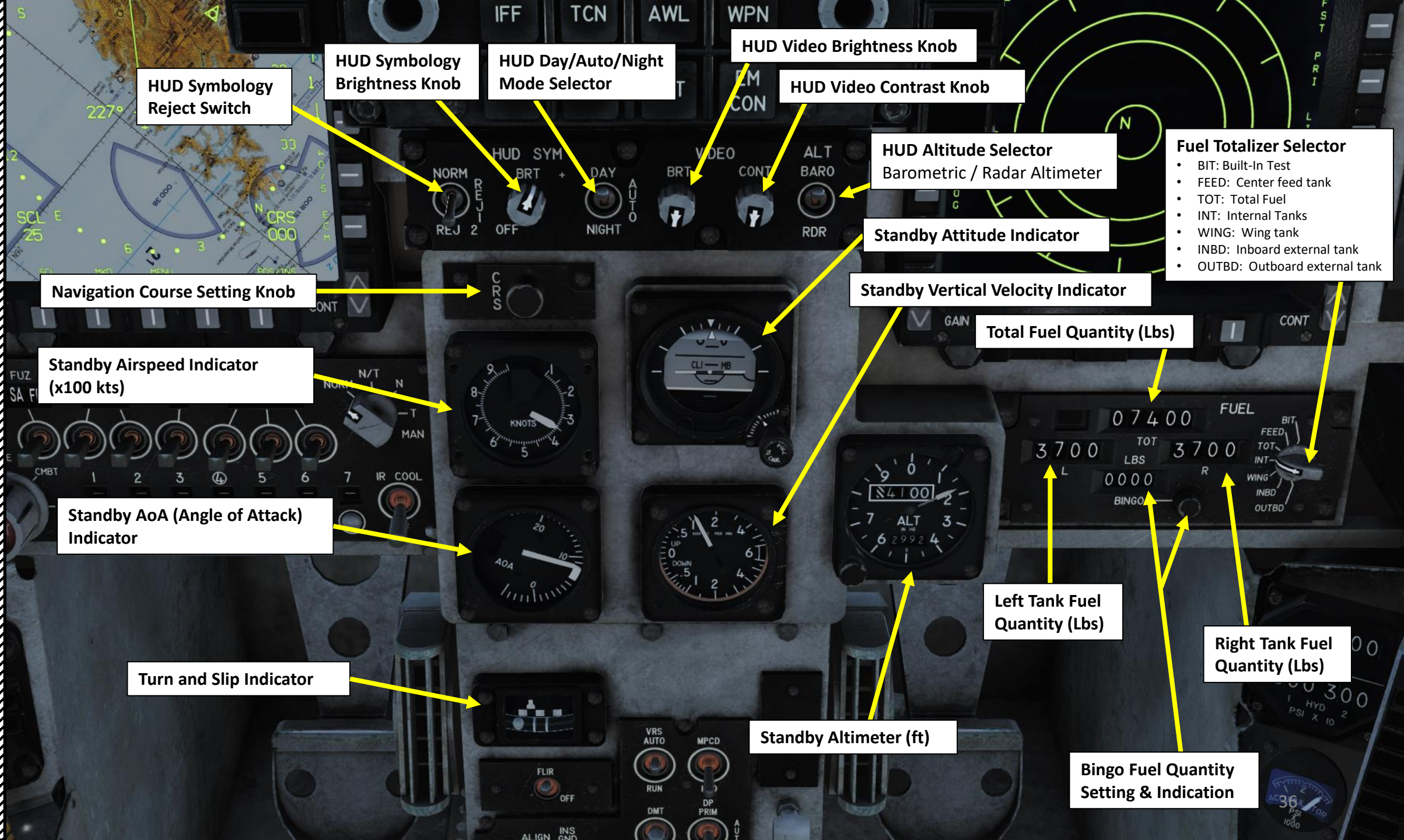

HUD Symbology Reject Switch

HUD Symbology Brightness Knob

HUD Day/Auto/Night Mode Selector

HUD Video Brightness Knob

HUD Video Contrast Knob

HUD Altitude Selector Barometric / Radar Altimeter

Fuel Totalizer Selector

- BIT: Built-In Test
- FEED: Center feed tank
- TOT: Total Fuel
- INT: Internal Tanks
- WING: Wing tank
- INBD: Inboard external tank
- OUTBD: Outboard external tank

Navigation Course Setting Knob

Standby Airspeed Indicator (x100 kts)

Standby AoA (Angle of Attack) Indicator

Turn and Slip Indicator

Standby Attitude Indicator

Standby Vertical Velocity Indicator

Total Fuel Quantity (Lbs)

Left Tank Fuel Quantity (Lbs)

Right Tank Fuel Quantity (Lbs)

Standby Altimeter (ft)

Bingo Fuel Quantity Setting & Indication

HUD SYM REJ 2 OFF

HUD SYM BRT + NIGHT

DAY AUTO

VIDEO BRT

VIDEO CONT

ALT BARO RDR

CRS

8 7 6 5 4 3 2 1

KNOTS

20 10 0

AOA

TURN AND SLIP

CLI MB

5 4 3 2 1

UP DOWN

9 0 1 2 3 4 5 6

ALT

07400

FUEL

3700

TOT LBS 3700

0000

BINGO

BIT FEED TOT INT WING INBD OUTBD

VRS AUTO

MPCD

DMT

DP PRIM

ALIGN

INS GND

AUT

**DMT (Dual Mode Tracker) Toggle Switch**  
ON / OFF

**Video Recorder System (VRS) Switch**  
AUTO / RUN

**Video Recorder System (VRS) Display Selector**  
MPCD / HUD

**FLIR Power Switch**  
UP = ON  
DOWN = OFF

**Dual Processor (DP) Mode Selector Switch**  
PRIMARY / AUTO / ALTERNATE

**INS (Inertial Navigation System) Mode Selector**

- OFF: No Power to INS
- TEST: INS BIT (Built-In Test)
- GB: Not used
- GYRO: Emergency mode
- IFA: Initiates INS In-Flight Alignment
- NAV: INS Navigation mode
- INS GND: INS Ground Align mode
- SEA: INS Sea Align mode

**Mission Computer (MC) Mode Switch**  
OVERRIDE/AUTO/OFF

**Probe (PRB) Heat Mode Switch**  
HEAT/AUTO

**Sensor Select Switch**  
AFT = DMT: LST/TV  
FWD = INS: IRMV/EOMV  
LEFT = MAP Center/Decenter  
RIGHT = FLIR/HUD-BH/WH  
DOWN (PUSHED) = HUD Scene Reject/TPOD

**Trim Hat Switch  
(Pitch & Bank)**

**Waypoint Increment Button**

**Air-to-Ground Bomb Pickle Button**  
Releases bombs or launches rockets or  
Maverick air-to-ground missiles

**Trigger (front of stick)**  
Fires gun or launches Sidewinder or Sidearm  
missile

**Air-to-Air Weapon Select Switch**  
AFT = A/A Sidewinder SEAM Mode  
FWD = A/A Sidewinder Boresight Mode  
DOWN (PUSHED) = Gun Mode

**Emergency SAAHS Disconnect Switch**  
Disengages SAAHS (Stability Augmentation and Attitude  
Hold System)

**Air-to-Ground Target Undesignate / Nosewheel Steering  
Button**



Harness Adjustment Lever

Seat Ejection Handle

Tachometer: Compressor (HI) or fan (LO) RPM

EDP (Engine Display Panel) BIT (Built-In Test) Button

Engine Reaction Control System Duct Pressure Indicator (psi)

Fuel Flow Indicator (lbs/min)

Stabilator Position (Trim) Indicator  
Shown: nose down (↓) 2 deg

RWR (Radar Warning Receiver) Control Knob  
OFF / ON / Volume

**Expendables Dispenser Control Knob**  
 OFF: No Power  
 AUT: Dispenser selected automatically  
 UP: Dispensers on top of aft fuselage used first  
 DOWN: Dispensers on bottom of aft fuselage used first  
 RWR: Option not available

**ECM (Electronic Countermeasure) Control Knob**  
 OFF: Removes power to DECM pod  
 STBY: Powers DECM pod but does not emit signal  
 BIT: DECM pod Built-In Test  
 RCV: Smart Standby (pod emits based on signal received)  
 RPT: Continuous jamming signal (repeat)

JPT (Jet Pipe Temperature) Indicator (deg C)

Nozzle Angle Indicator (deg)

**Threat Lights**

- SAM: SAM launch detected
- CW: Ground Tracking (Continuous Wave) radar is locked on aircraft
- AI: Air Intercept radar is locked on aircraft (flashes if launch is detected)
- AAA: Anti-Aircraft Artillery gun radar is locked on aircraft.

EDP (Engine Display Panel) Brightness Control

Water Quantity Indicator (lbs)

Water Injection Flow Light

Clock

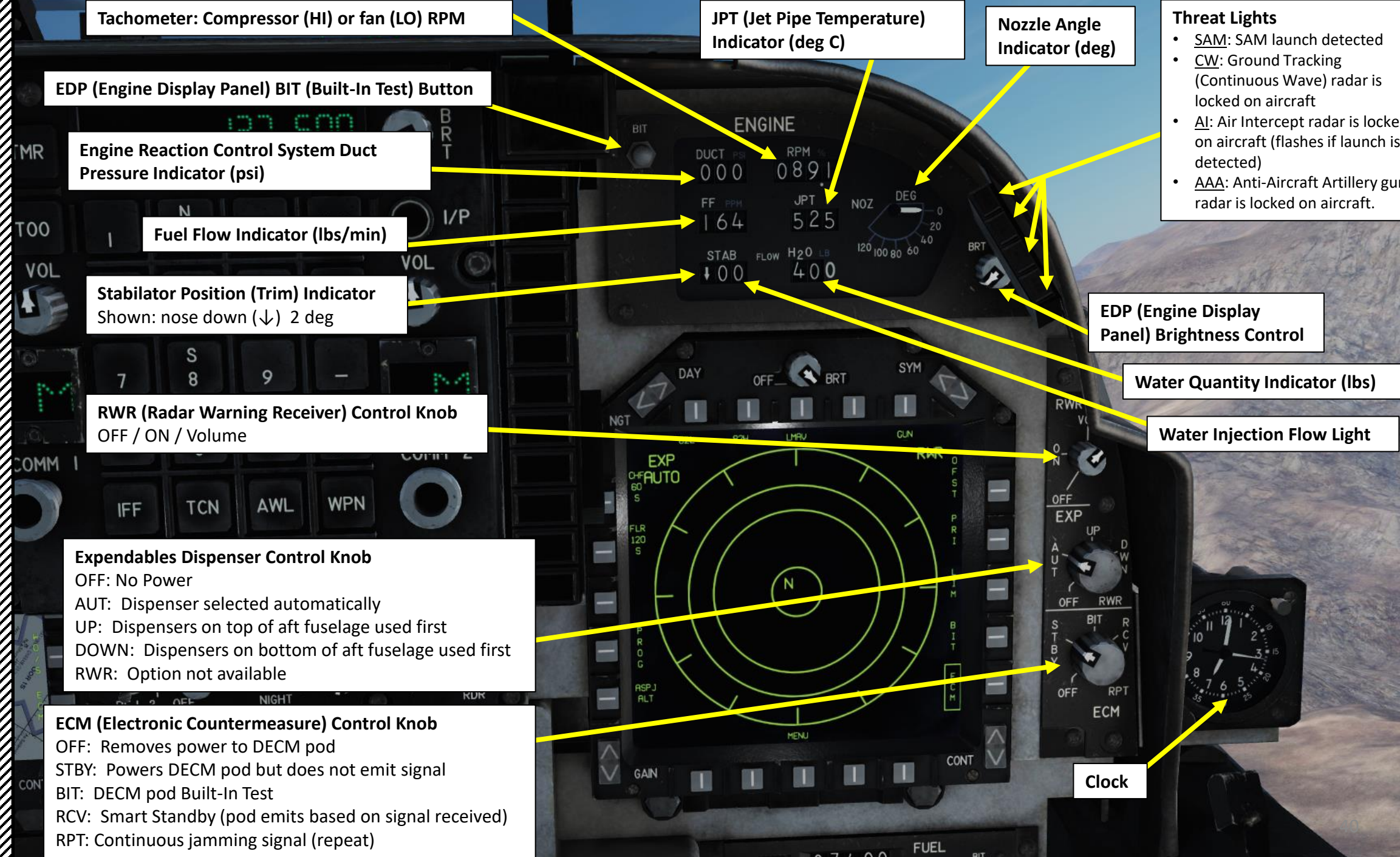



**Flood Lamps**

Scroll mousewheel to change orientation

**Canopy Handle**

Key Binding: LCTRL+C

**Canopy Locking Lever**

FWD: LOCKED  
AFT: UNLOCKED

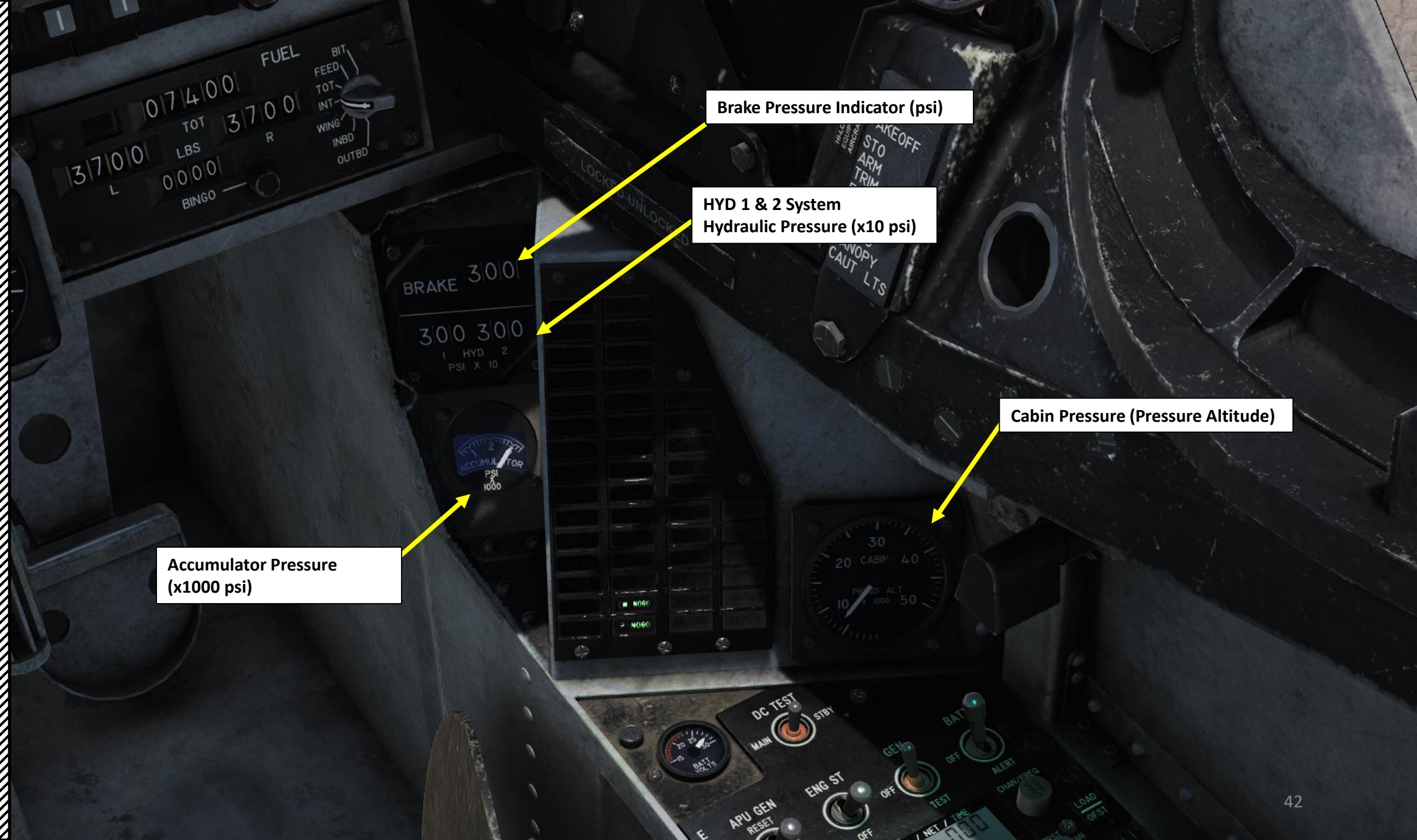

Brake Pressure Indicator (psi)

HYD 1 & 2 System  
Hydraulic Pressure (x10 psi)

Accumulator Pressure  
(x10000 psi)

Cabin Pressure (Pressure Altitude)



**CAUTION / ADVISORY LIGHT PANEL**

<b>OXY</b> OBOGS (On-Board Oxygen Generation System) malfunction	<b>WSHLD</b> Windshield hot		
<b>HYD 1</b> Hydraulic System 1 pressure greater than 1400 psi	<b>HYD 2</b> Hydraulic System 2 pressure greater than 1400 psi		
<b>L PUMP</b> Left fuel boost pump pressure low	<b>R PUMP</b> Right fuel boost pump pressure low		
<b>L TRANS</b> Low air pressure to left feeder tank	<b>R TRANS</b> Low air pressure to right feeder tank		
<b>FLAPS 1</b> Flaps 1 channel failed	<b>FLAPS 2</b> Flaps 2 channel failed	<b>AUT FLP</b> Auto flap mode or ADC failed	
<b>PROP</b> Fuel proportioner off or failed	<b>LIDS</b> LIDS (Lift Improvement Device System) not in correct position	<b>OIL</b> Oil pressure low	
<b>APU GEN</b> APU (Auxiliary Power Unit) selected and emergency generated failed		<b>GPS</b> GPS not valid	
<b>DEP RES</b> Departure Resistance reduced (aircraft more prone to depart from controlled flight)	<b>DC</b> Main transformer-rectifier failed	<b>STBY TR</b> Standby TRU (Transformer-Rectifier Unit) inoperative or offline	
<b>CS COOL</b> Cockpit avionics cooling fan failed	<b>LOAD</b> Fuel asymmetry over VL (Vertical Landing) limit	<b>CANOPY</b> Canopy not closed and locked	
<b>INS</b> Inertial Navigation System aligning or failed	<b>SKID</b> Anti-Skid system malfunction	<b>EFC</b> DECU 1 or 2 (Digital Engine Control Unit) failed	<b>NWS</b> Nosewheel steering malfunction
<b>AFC</b> AFC (Automatic Flight Controls) malfunction or deselected	<b>CIP AUT</b> Computed delivery mode not available	<b>H<sub>2</sub>O SEL</b> Airspeed over 250 kts and water injection switch is not set to OFF	<b>APU</b> APU (Auxiliary Power Unit) operating
<b>PITCH</b> Pitch stabilization augmentation system off or failed	<b>IFF</b> IFF (Identify-Friend-or-Foe) system off, not zeroized or not responding.	<b>SPD BRK</b> Gear up and speed brake extended or gear down and speed brake not 25 deg	<b>DROOP</b> Ailerons dropped
<b>ROLL</b> Roll stabilization augmentation system off or failed	<b>AFT BAY</b> Aft avionics bay ECS (Environmental Control System) failed		
<b>YAW</b> Yaw stabilization augmentation system off or failed	<b>CW NO GO</b> CW (continuous wave) radar jammer failure.	<b>P JAM</b> Pulse-Doppler radar jammer pod active	<b>JMR HOT</b> Jammer pod overtemperature
<b>ENG EXC</b> Engine exceedance (overspeed, overtemperature or over-g) detected	<b>P NO GO</b> Pulse-Doppler radar jammer failure.	<b>CW JAM</b> CW (continuous wave) radar jammer pod active.	<b>REPLY</b> IFF responding to Mode 4 interrogation.

**DC Test Switch**

LEFT: MANUAL  
MIDDLE: OFF  
RIGHT: STANDBY

**Generator Switch**

FWD: GEN/ON  
MIDDLE: OFF  
AFT: TEST

**Battery Switch**

FWD: BATT/ON  
MIDDLE: OFF  
AFT: ALERT

**DC Voltmeter (Volts)**

**APU (Auxiliary Power Unit) Generator Switch**

- FWD: Reset
- MIDDLE: ON (with battery set to BATT, GTS (Gas Turbine Starter) drives the APU provided it is not in the engine start mode)
- AFT: OFF

**Engine Start (ENG ST) Switch**

FWD: Engine Start ON  
AFT: OFF

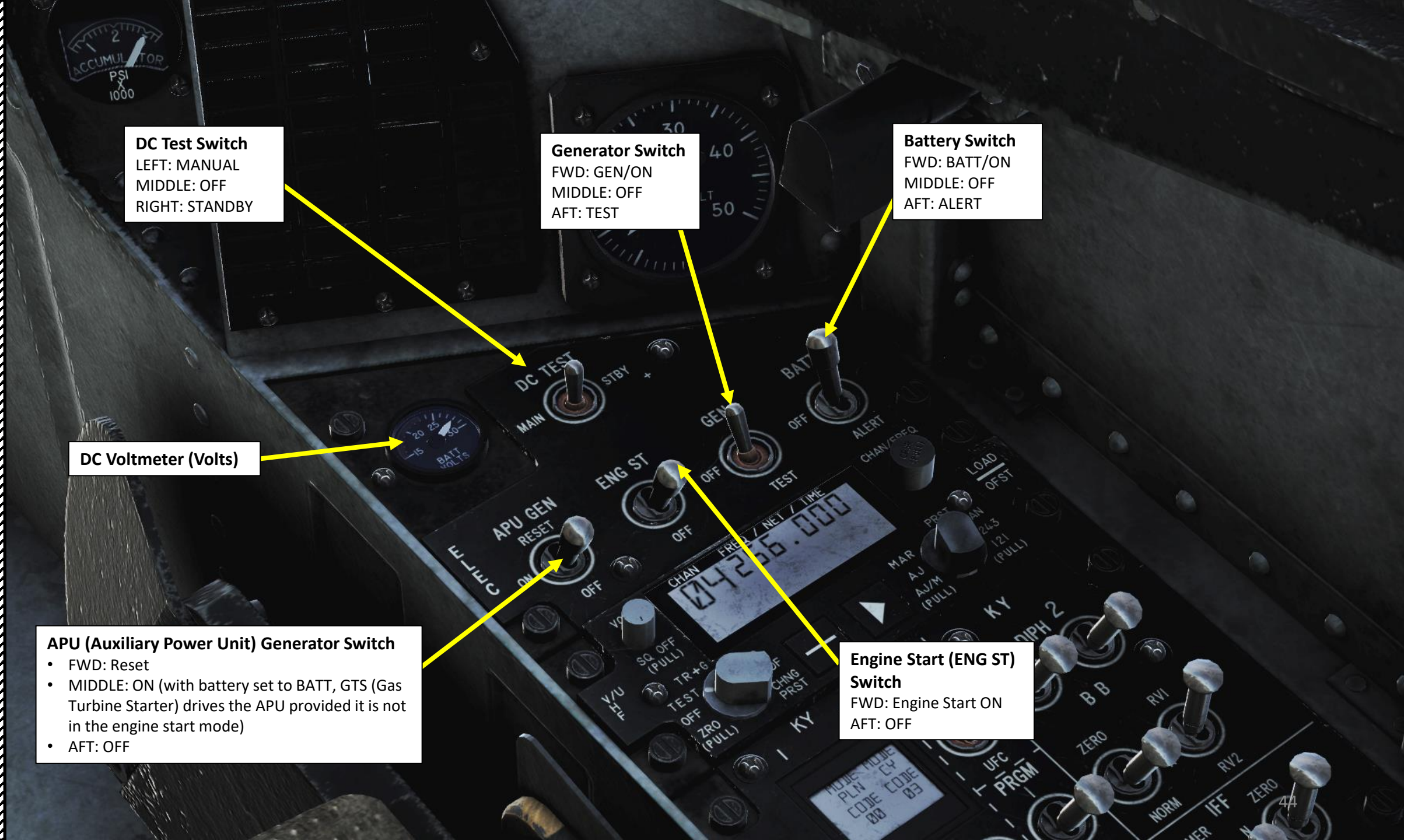

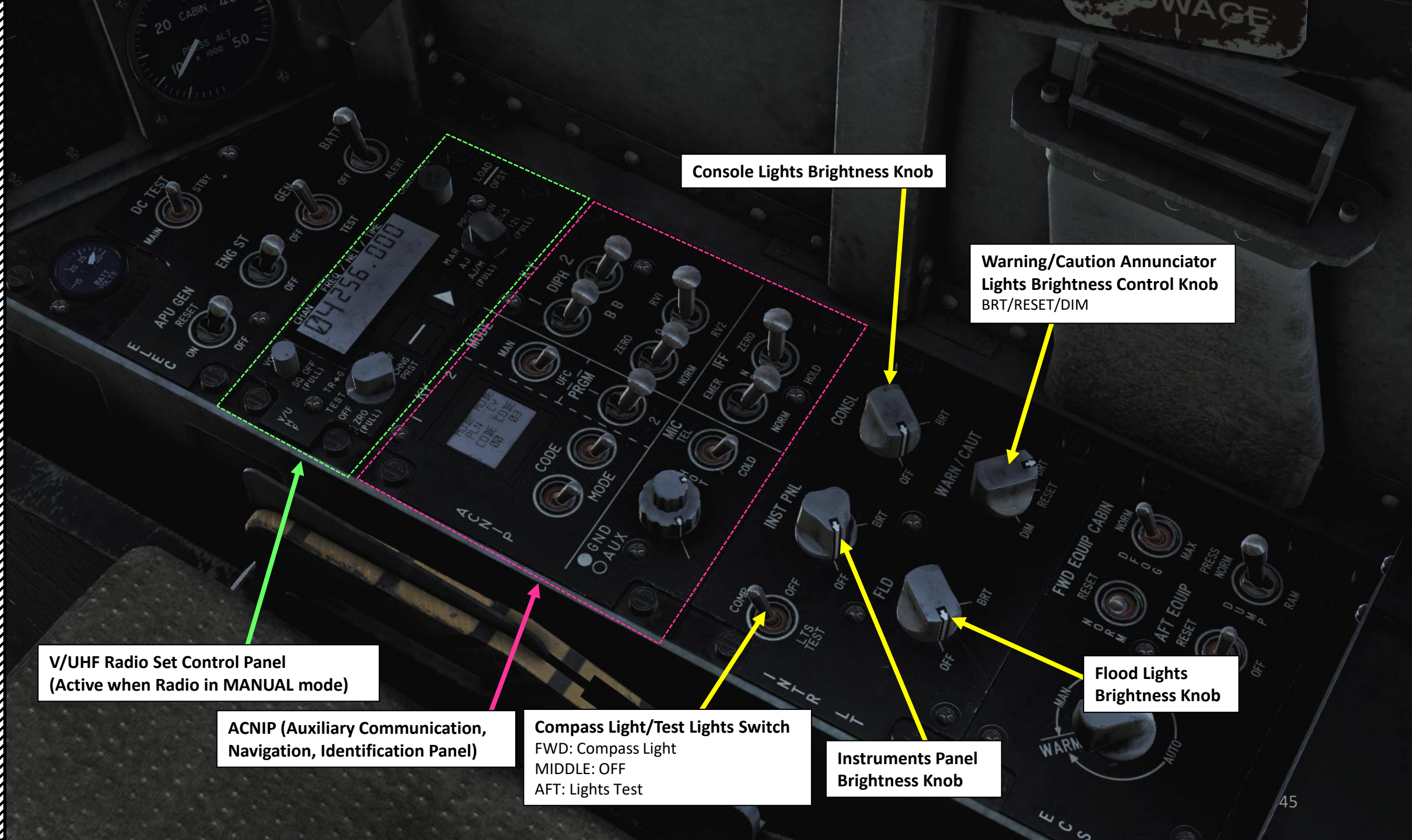

Console Lights Brightness Knob

Warning/Caution Annunciator  
Lights Brightness Control Knob  
BRT/RESET/DIM

V/UHF Radio Set Control Panel  
(Active when Radio in MANUAL mode)

ACNIP (Auxiliary Communication,  
Navigation, Identification Panel)

Compass Light/Test Lights Switch  
FWD: Compass Light  
MIDDLE: OFF  
AFT: Lights Test

Instruments Panel  
Brightness Knob

Flood Lights  
Brightness Knob

V/UHF Active Manual Frequency Selected

V/UHF Preset Channel Selected

V/UHF Time (Not simulated)

V/UHF Network (Not simulated)

V/UHF RSC Volume Control Knob  
Turned: Volume  
Pulled: Squelch OFF

V/UHF RSC Channel Frequency Tuner

**V/UHF RSC (Radio Set Control) Channel Frequency Mode Selector**

- AJ/M: Not simulated
- AJ: Not simulated
- MAR: Selects one of 57 preset maritime channels. Not simulated
- PRST: CRS Switch changes selected preset channel.
- MAN: CRS Switch changes the frequency for the selected channel.
- 243: Turns on receivers for the 243.000 Mhz emergency frequency.
- 121: Turns on receivers for the 121.000 Mhz tactical frequency. Not simulated

**V/UHF Ancillary Mode Switch**  
Positions cursor under various mode options. Used with ancillary mode pointer to select or deselect ancillary modes.

**V/UHF Ancillary Mode Pointer**  
Positions pointer to select or deselect ancillary mode option defined by the – pushbutton.

**V/UHF RSC (Radio Set Control) Channel Operational Mode Selector**

- Pulled (ZRO): Not Simulated
- OFF: Turns RCS OFF
- TEST: Selects internal BIT (Built-In-Test).
- TR+G: Selects Receiver/Transmitter and GUARD receivers
- TR: Selects Receiver/Transmitter
- ADF: Automatic Direction Finder (not equipped on Harrier)
- CHNG PRST: Preset Channel Change

**V/UHF Radio Control Mode Switch**

- MAN: Manual Mode (radio is controlled by the Radio Control Set panel)
- UFC: Up-Front Controller Mode (radio is controlled by the UFC and ODU, Option Display Unit)

**Radio Program 1/2 Switch**  
 Selects which radio transmitter is active

**KY58 Secure Speech System Unit 1 Diphase/Baseband (DIPH/BB) Selector**

**KY58 Secure Speech System Unit 2 Diphase/Baseband (DIPH/BB) Selector**

**KY-58 Remote Variable Codes Load Switch**  
 RV1: Not Simulated  
 RV2: Not Simulated

**KY-58 Secure Speech System Unit #1 and Unit #2 Code and Mode Selected**  
 The secure speech system is used for ciphering (coding) or deciphering (decoding) audio routed through the KY-58 cipher unit No. 1 (KY-1) or KY-58 unit No. 2 (KY-2).

**KY58 Cipher Zero Norm Switch**

**IFF (Identify-Friend-or-Foe) Zero/Hold Switch (Not Simulated)**

**KY-58 Unit #2 Code/Mode Switch (Not Simulated)**

**IFF (Identify-Friend-or-Foe) Emergency/Normal Switch (Not Simulated)**

**KY-58 Unit #1 Code/Mode Switch (Not Simulated)**  
 Used to select a desired KY58 operating mode and code

**ICS (Intercommunication System) Mic (Microphone) Operational Mode Switch**  
 TEL / HOT MIC / COLD MIC

**ICS (Intercom System) Ground Volume Knob**

**ICS (Intercom System) Auxiliary Volume Knob**  
 Can be used to tune volume of aural warnings (i.e. Bitchin' Betty)

**Defogging Switch**  
FWD: Normal  
MIDDLE: Defog  
AFT: Maximum Defog

**Flood Lamps**

**Cockpit Pressure Switch**  
FWD: Normal Pressure regulator  
MIDDLE: Dump cockpit pressure  
AFT: Ram air

**Aft Equipment Bay Cooling Switch**  
FWD: Reset  
MIDDLE: ON  
AFT: OFF

**ECS (Environmental Control System) Cabin Temperature Controller Knob**

**Forward Equipment Bay Cooling Switch**  
FWD: Reset  
AFT: Normal

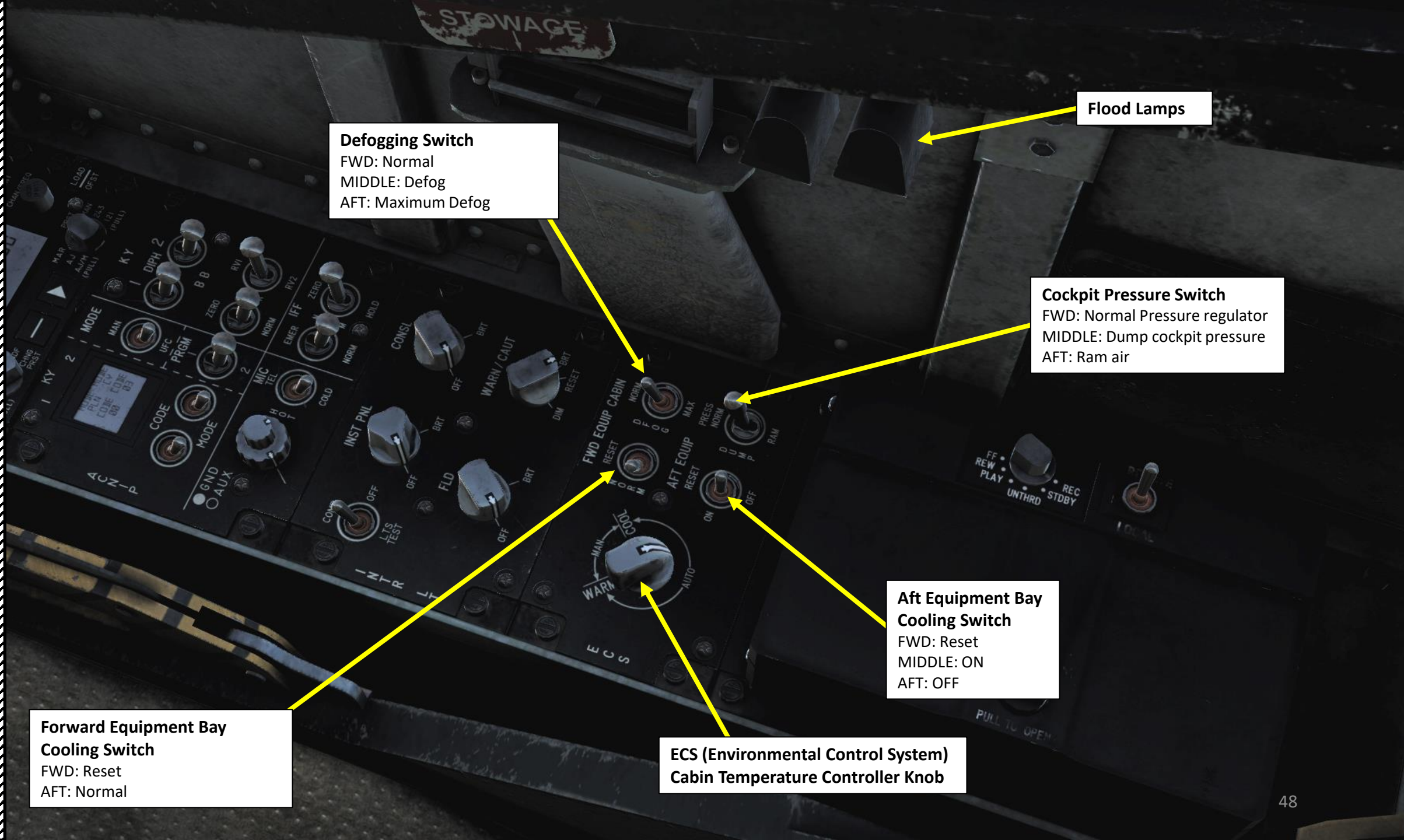

Altitude	100	150	200	250	300	350	400	450	500	550	600	650	700	750	800	850	900	950	1000
Speed	150	175	200	225	250	275	300	325	350	375	400	425	450	475	500	525	550	575	600
Speed	150	175	200	225	250	275	300	325	350	375	400	425	450	475	500	525	550	575	600

NVG (Night Vision Goggle)  
and Video Recorder Stowage



Seat Ground Safety Lever  
RETRACTED (DOWN): Safety OFF  
EXTENDED (UP): Safety ON





Ground Power Switches

SWITCH	POSITION	EQUIPMENT		
STORES	ACP	ARMAMENT CONTROL PANEL		
	SMS	STORES MANAGEMENT COMPUTER ARMAMENT CONTROL PANEL	TACTS	DECM/ASPJ
MISC	ON	TACAN EXT LTS	RWR	
DISP/FLT	ON	HUD EDP FLIR INVERTER UFC VRS	L/R MPCD VRS DSS DVMS ADC SAAHS	TURN AND SLIP INDICATOR STANDBY ATTITUDE INDICATOR STANDBY ALTIMETER STANDBY REFERENCE ALTIMETER VIBRATOR DISPLAY PROCESSOR-GENERATOR
CNI	MC	MISSION COMPUTER		
	ALL	MISSION COMPUTER CNI DATA COMPUTER RADAR ALTIMETER RADAR BEACON KY-58	UHF/VHF NO.1 UHF/VHF NO.2 ECM RWR IFF	INS DVMS RADAR DECM/ASPJ
IGN ISO	ON OFF	REFER TO ENGINE FUEL SYSTEM, PARAGRAPH 2.3.6.2		
JPTL TEST	MAX OFF AMPL	REFER TO ENGINE CONTROLS, PARAGRAPH 2.4.6		

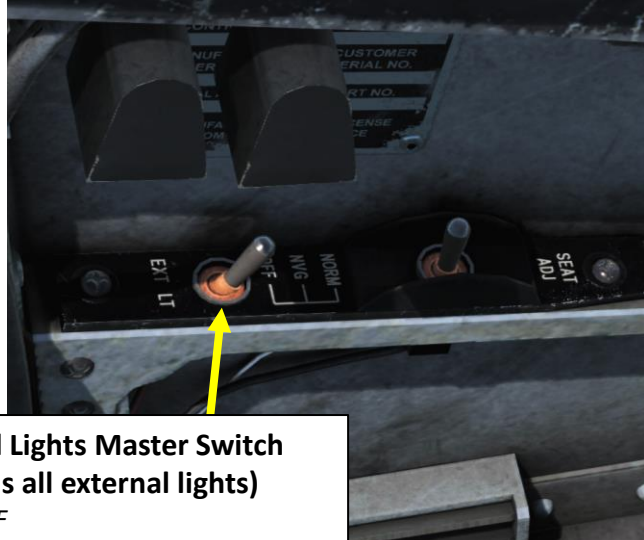
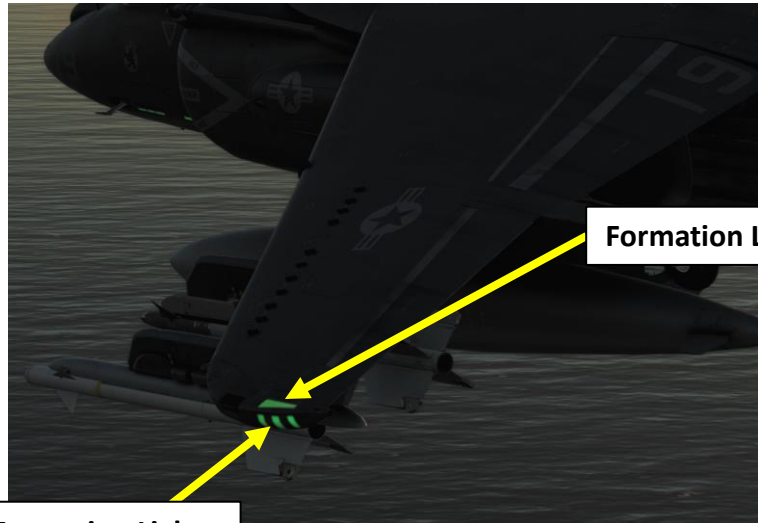
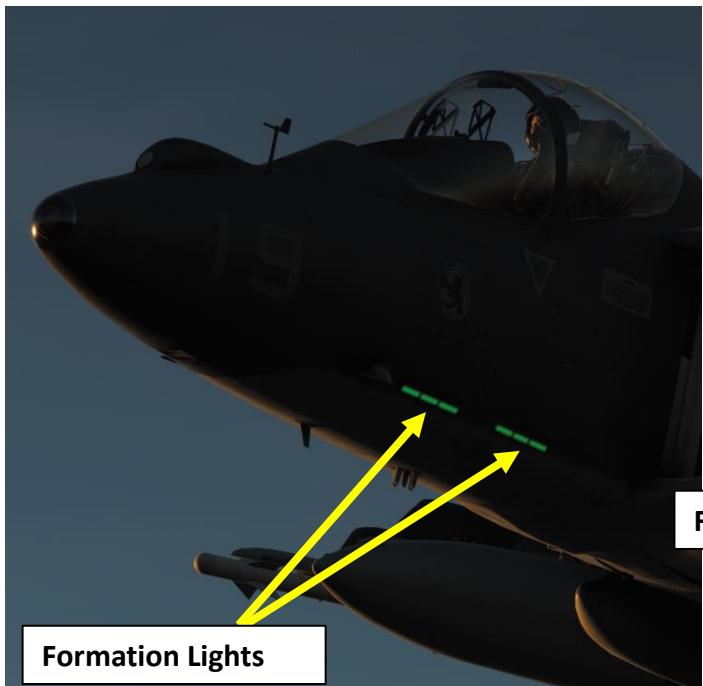

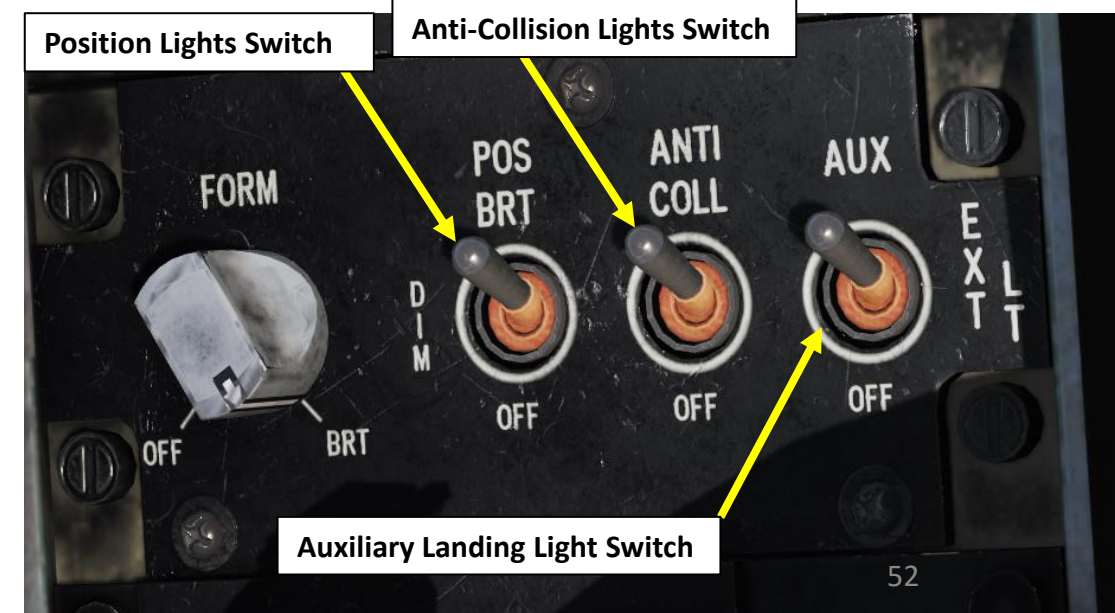
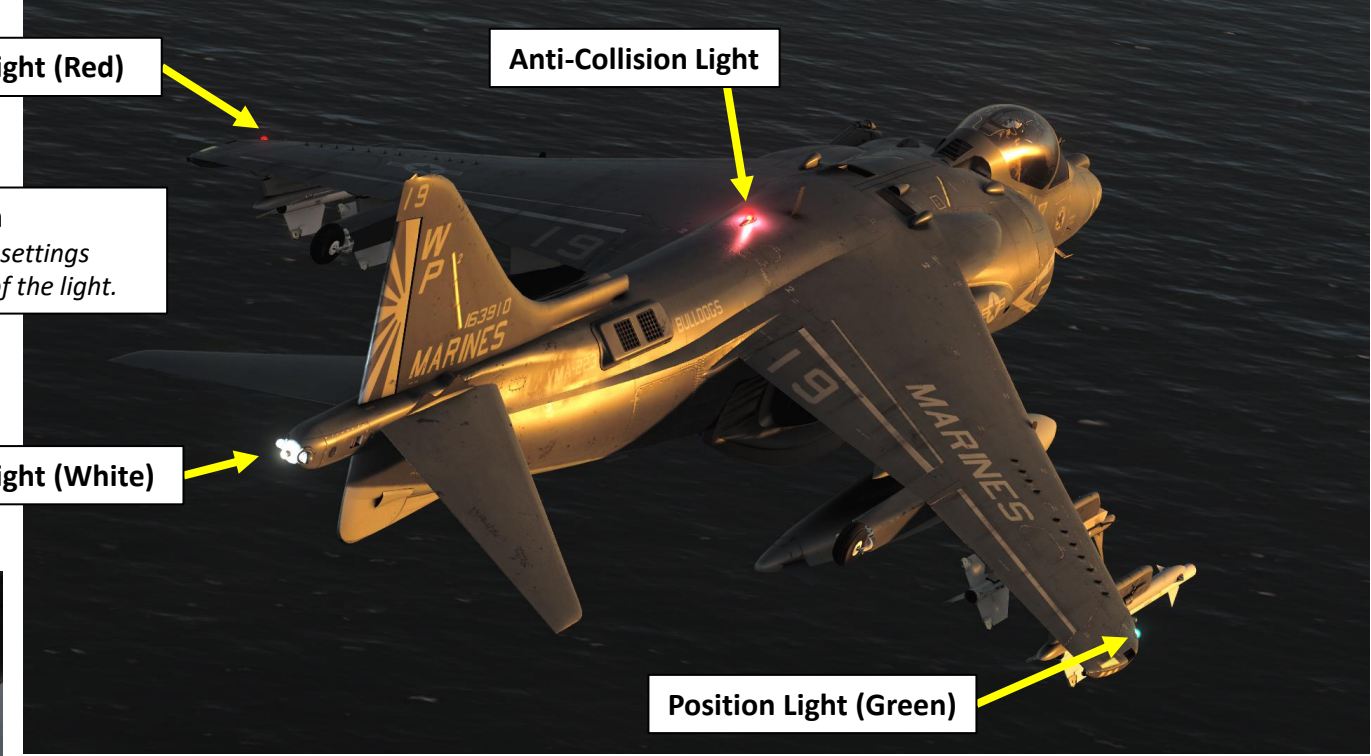
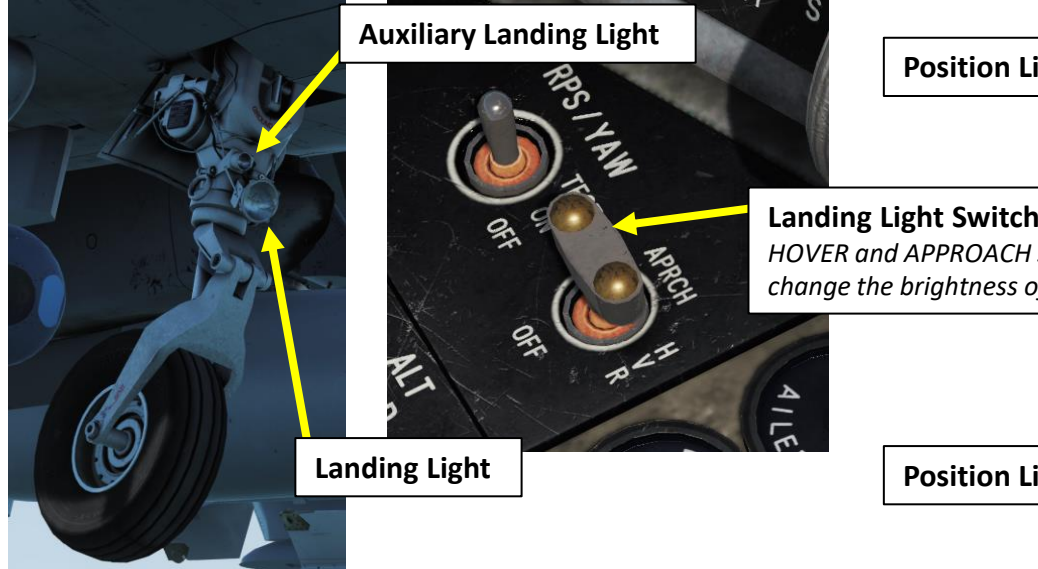

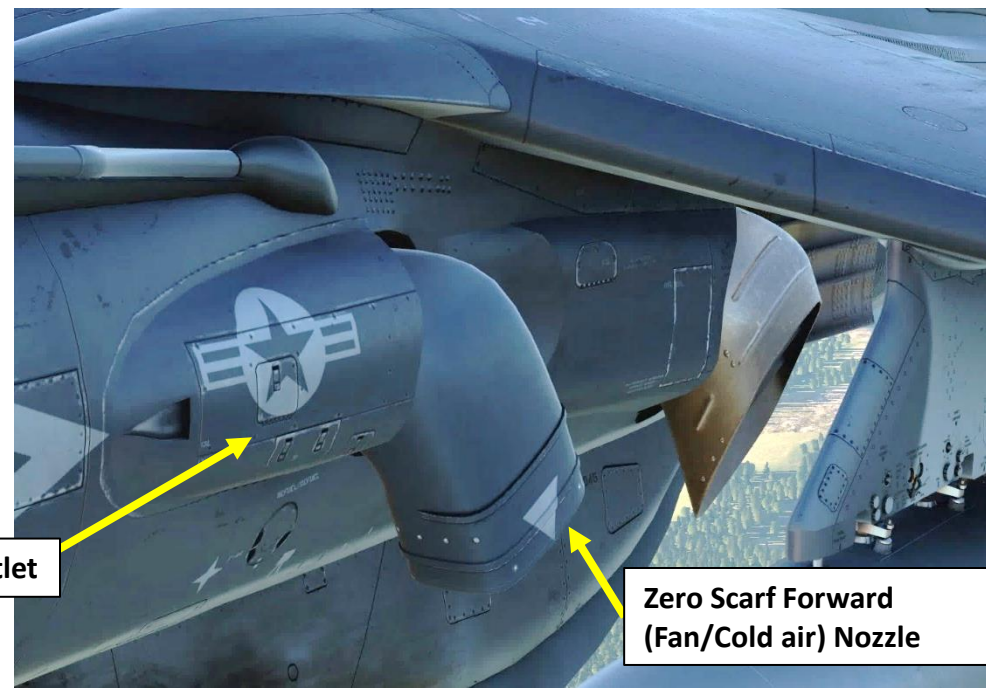

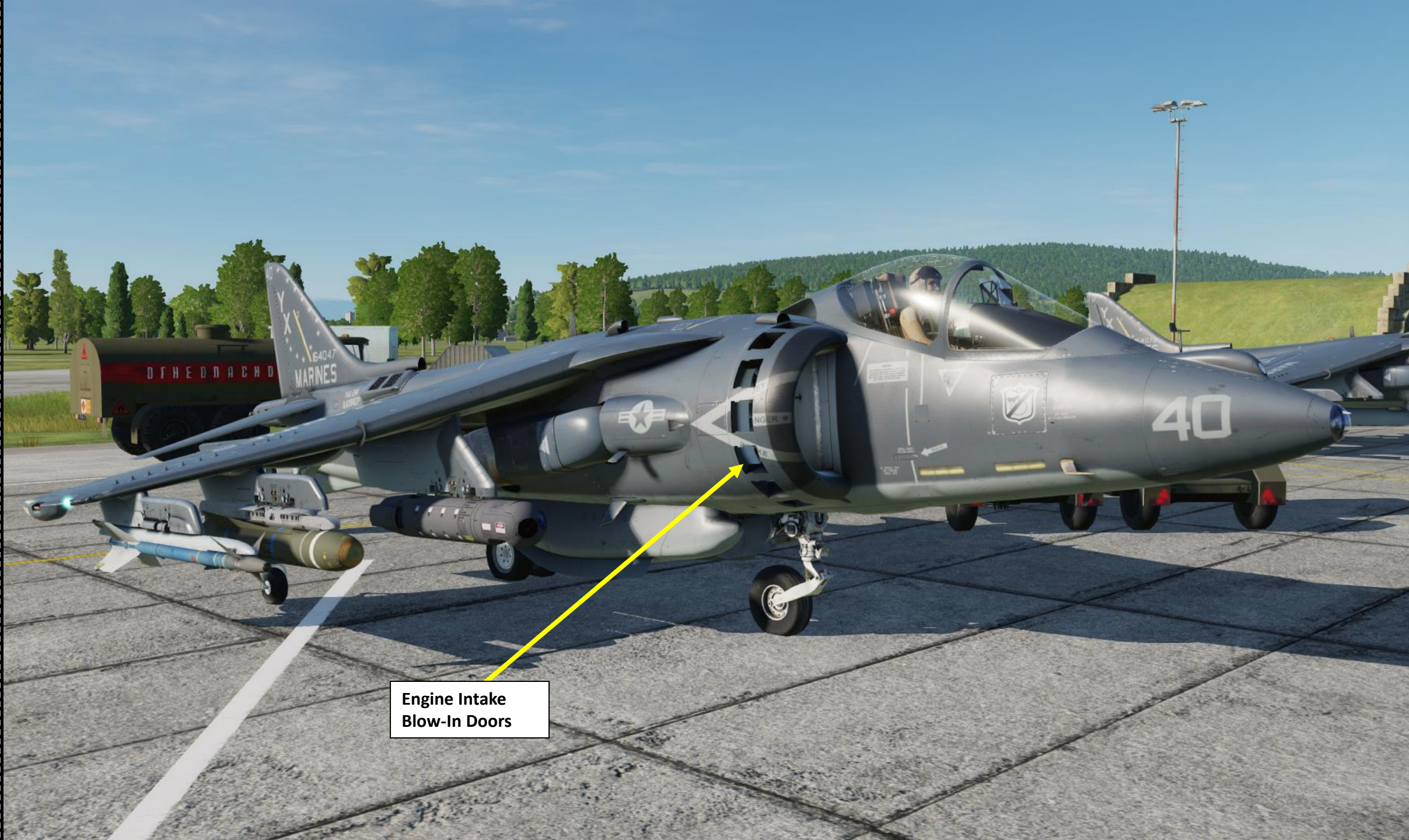

Engine Intake  
Blow-In Doors

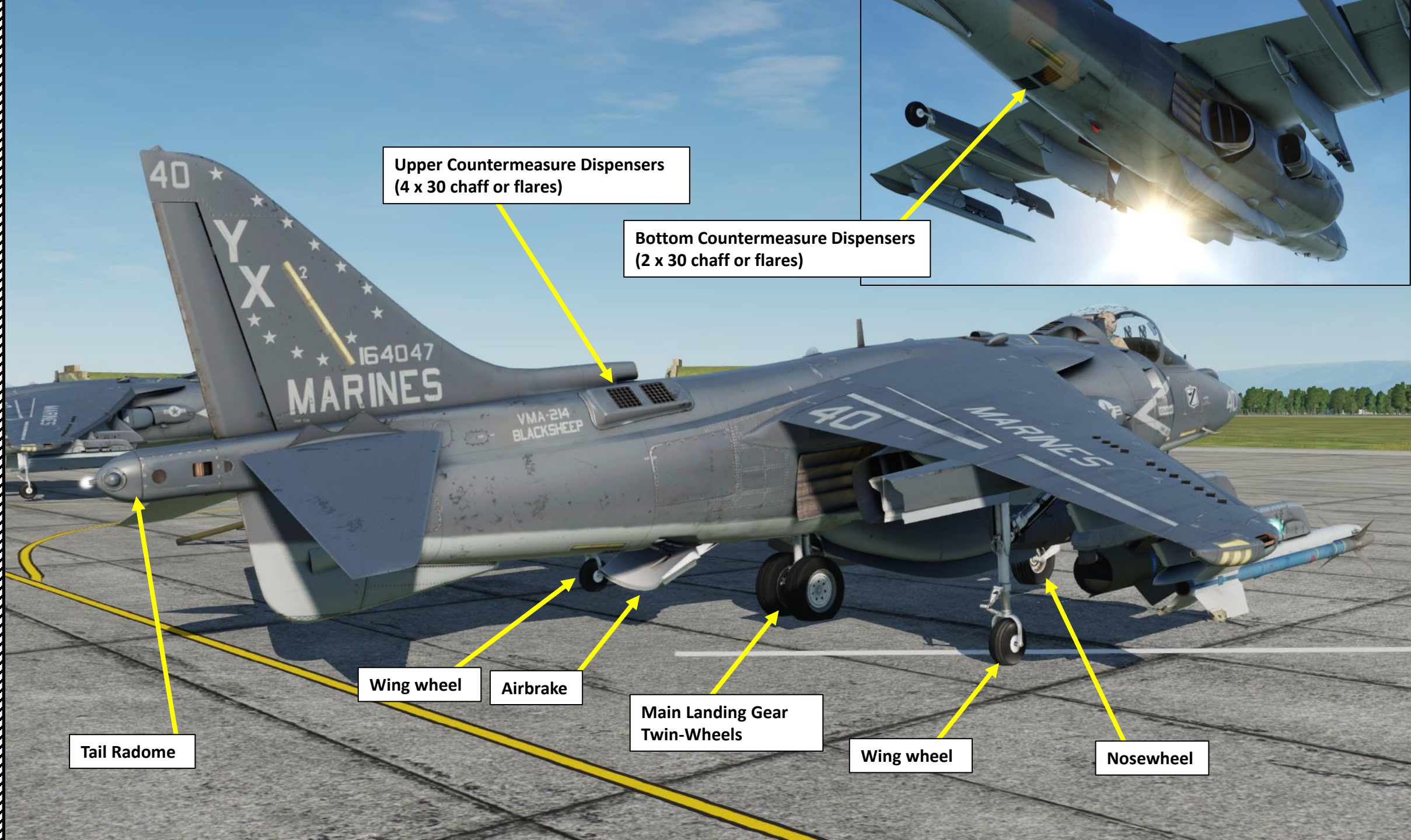

Upper Countermeasure Dispensers  
(4 x 30 chaff or flares)

Bottom Countermeasure Dispensers  
(2 x 30 chaff or flares)

Tail Radome

Wing wheel

Airbrake

Main Landing Gear  
Twin-Wheels

Wing wheel

Nosewheel

APU (Auxiliary Power Unit)  
Intake

APU (Auxiliary Power Unit)  
Exhaust Port





**Yaw Vane**  
*Used to get direction of wind relative to you.  
When hovering, you should make sure to keep it  
straight to hover into the wind direction.*





LIDS: Fence Deployed

LIDS: Strakes

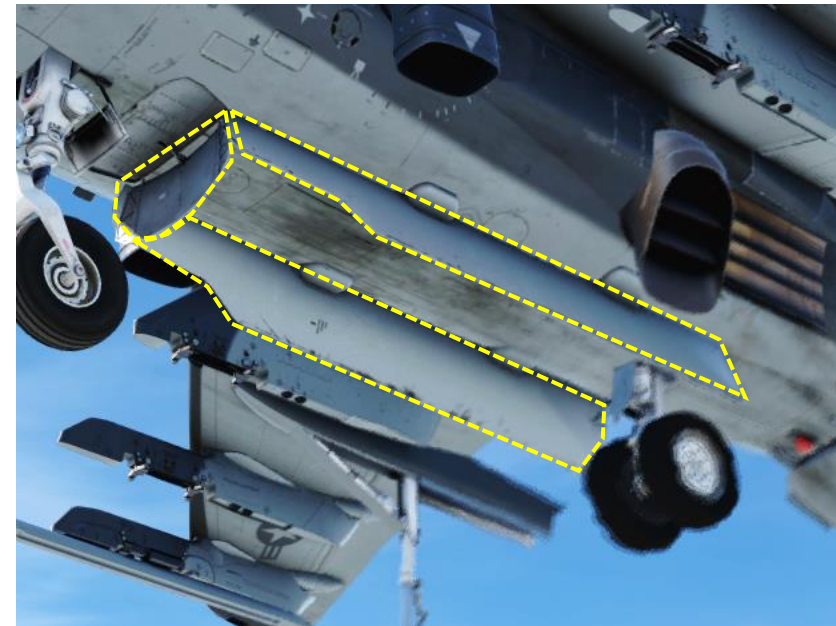

LIDS: Fence Retracted

**LIDS: Lift Improvement Device System**

The LIDS itself can be seen as the small wing-like structures or "Strakes" on the underside, underneath the nozzles. The LIDS switch controls the "fence" panel, which is located just behind the main landing gear to prevent the recirculating air cushion from escaping out the front.

When the harrier is in hover at low altitude, the recirculating air from the exhaust is harnessed to essentially form a cushion to provide additional lift during vertical landing.

LIDS are also designed to reduce the effect of hot gas ingestion (HGI) through recirculation of exhaust gases into the engine intake when operating vertically, since an increase in inlet temperature can cause a significant loss of thrust. This reduces HGI substantially.

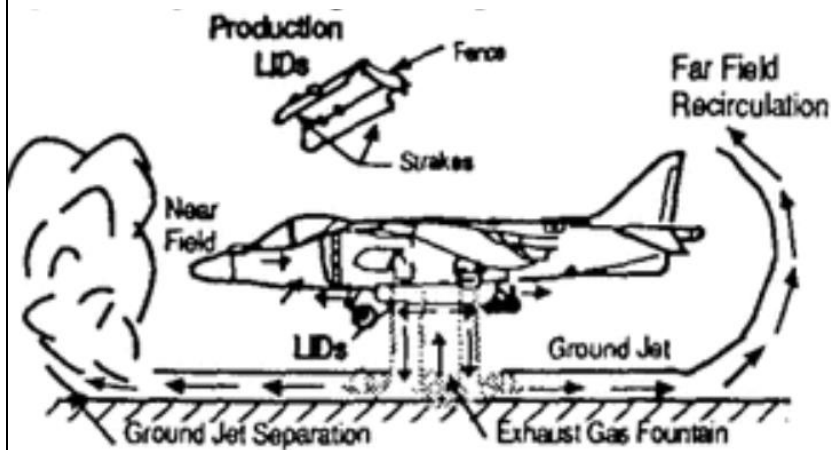
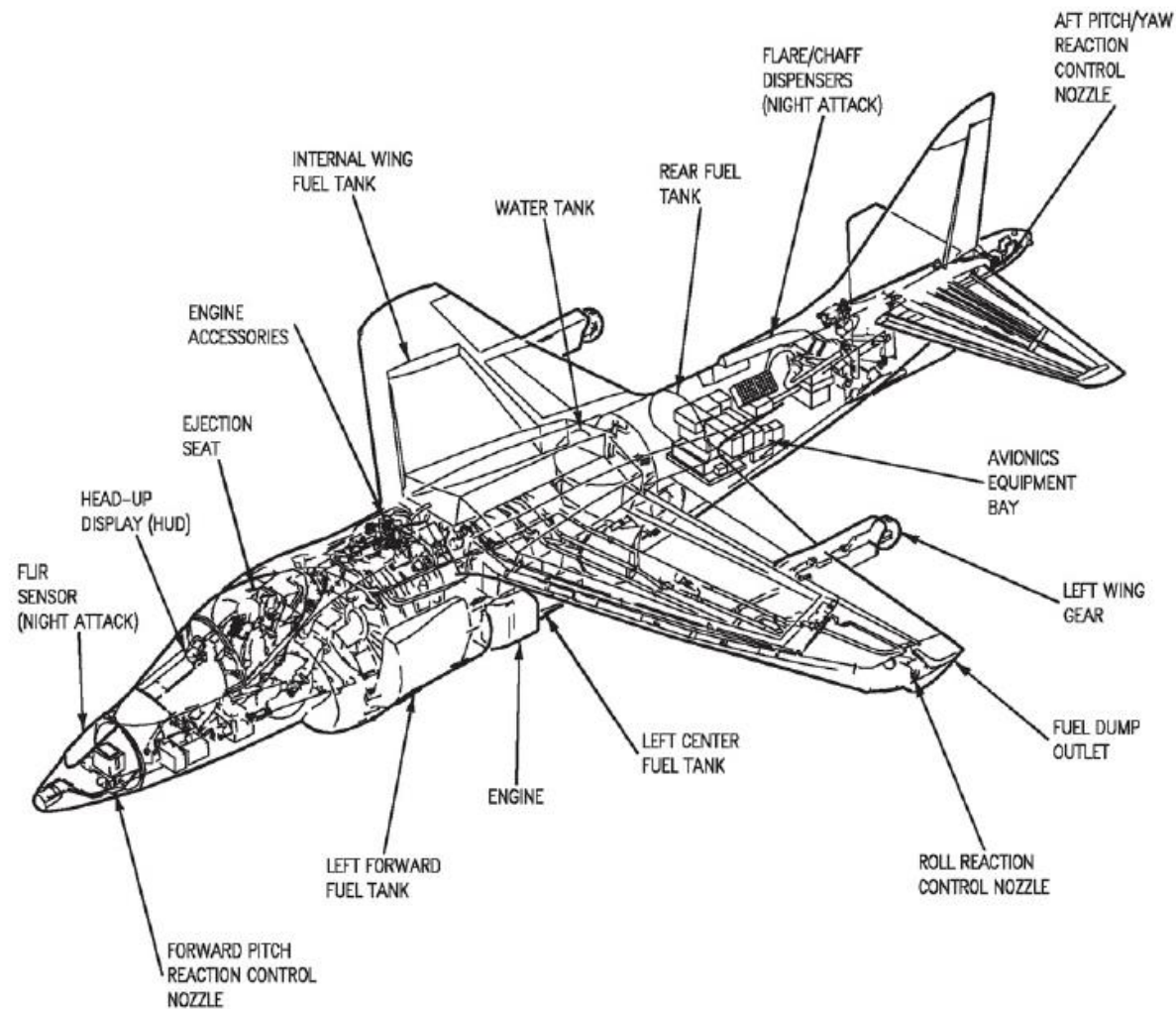

Figure 2. AV-8B HGI Phenomenon



AV-8B  
161573 THRU 164547



AIR BLEEDS-3rd STAGE LP

- ENGINE BAY VENTILATION
- REAR NOZZLE BEARING COOLING
- PRECOOLER-COOLANT FOR 6th STAGE BLEED (-40B/-40BA NON RADAR)
- PRECOOLER-COOLANT FOR 8th STAGE BLEED AIR (-40BA RADAR ONLY)

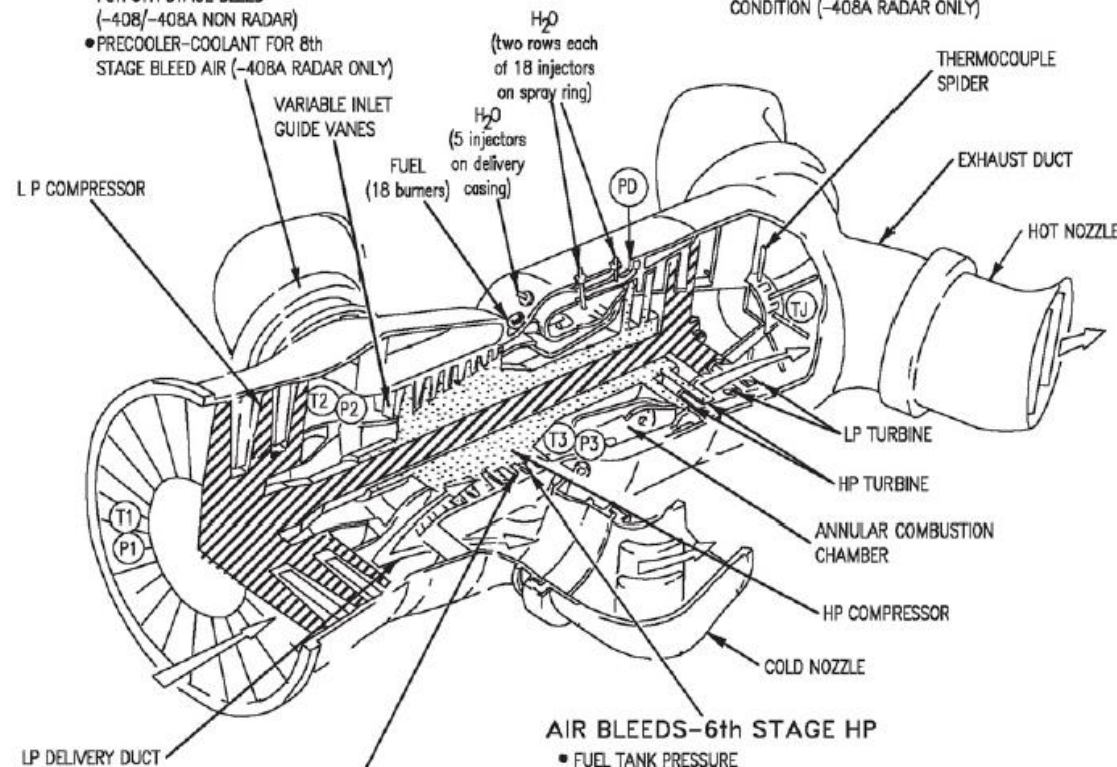

- AIR BLEEDS-8th STAGE HP
- REACTION CONTROLS PD
  - ON-BOARD OXYGEN P3 GENERATING SYSTEM PD
  - 25mm GUN SYSTEM
  - EQUIPMENT BAY AND COCKPIT CONDITION (-40BA RADAR ONLY)

AIR BLEEDS-6th STAGE HP

- FUEL TANK PRESSURE
- H<sub>2</sub>O PUMP
- EQUIPMENT BAY AND COCKPIT CONDITIONING
- ANTI-G SYSTEM
- CANOPY SEALS
- ENGINE NOZZLE DRIVE

NOTES

DELIVERY AIR PRESSURES

- P1 intake
- P2 LP Compressor
- P3 HP Compressor
- PD P3 duct differential when bleed demand made

DELIVERY AIR TEMPERATURES

- T1 intake
- T2 LP Compressor
- T3 HP Compressor
- TJ Exhaust duct

**Aircraft Designation**

The Tail Number you enter in the Mission Editor are actually the last three digits of the aircraft's Bureau Number (BuNo), or the USN/USMC serial number. For tactical aircraft, the BuNo is unrelated to the aircraft's "Side Number" (the one you see painted on the nose and flaps). The "Side Number" you see on the aircraft is the first the first BuNo digits reversed so that there is no obvious correlation.

**As an example:** "810" entered in the Tail # field of the mission editor will give "18" on the aircraft's "Side Number".

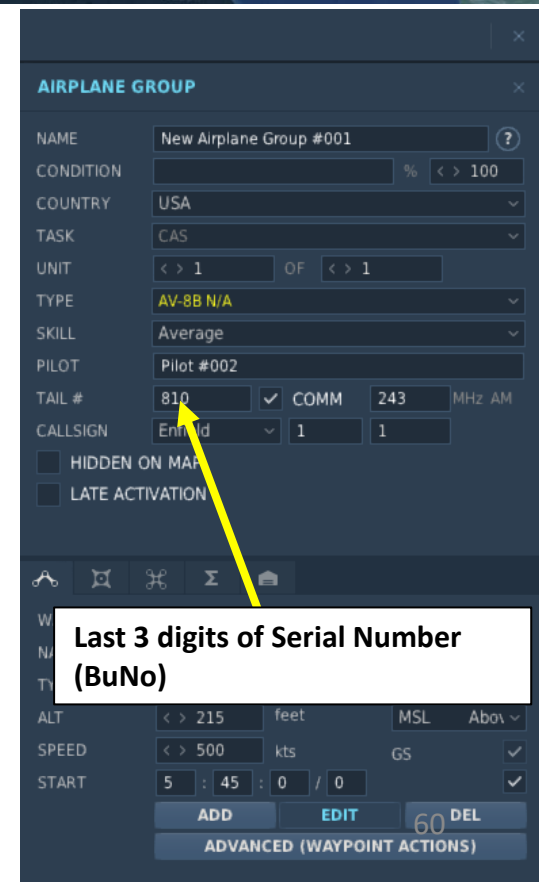
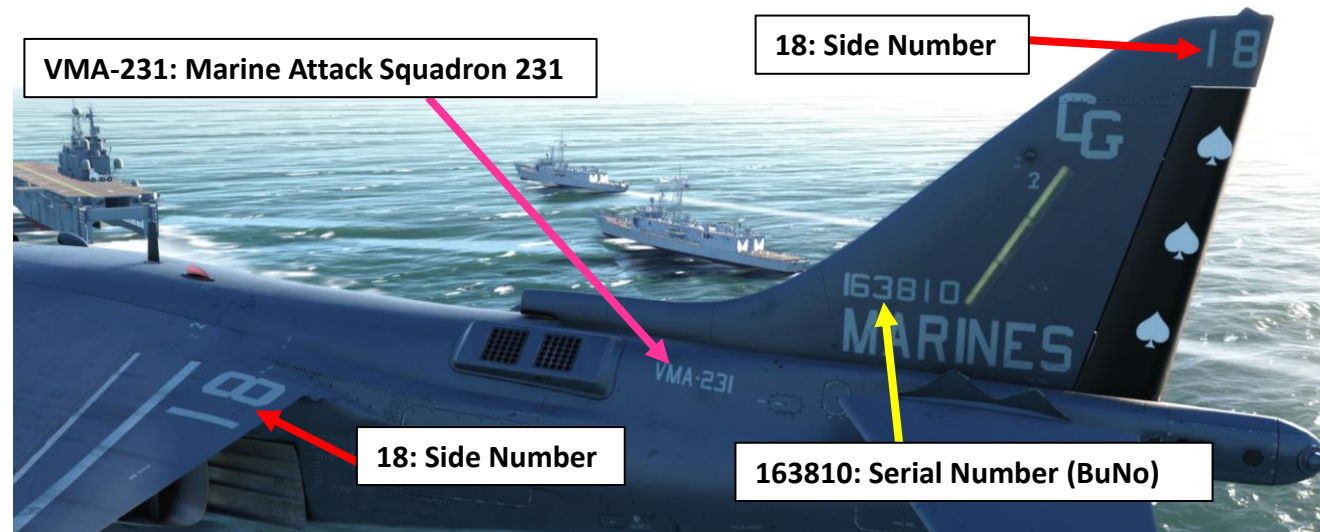



NVGs are stored in this box

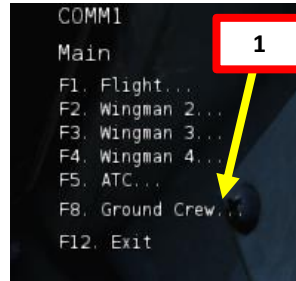

1

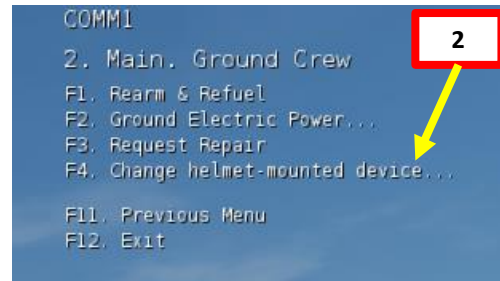

2

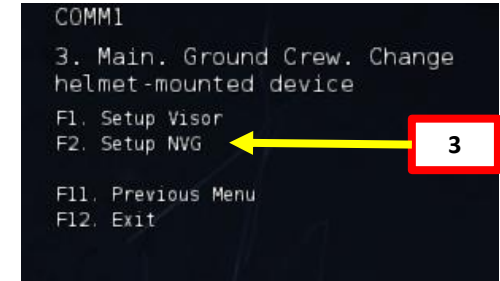

3

**Note 1:** You must contact the ground crew to equip either the Helmet Visor or Night Vision Goggles (NVGs). Using “\”, then F8 (Ground Crew), then F4 (Change helmet-mounted device) then either F1 or F2 for your desired helmet type.

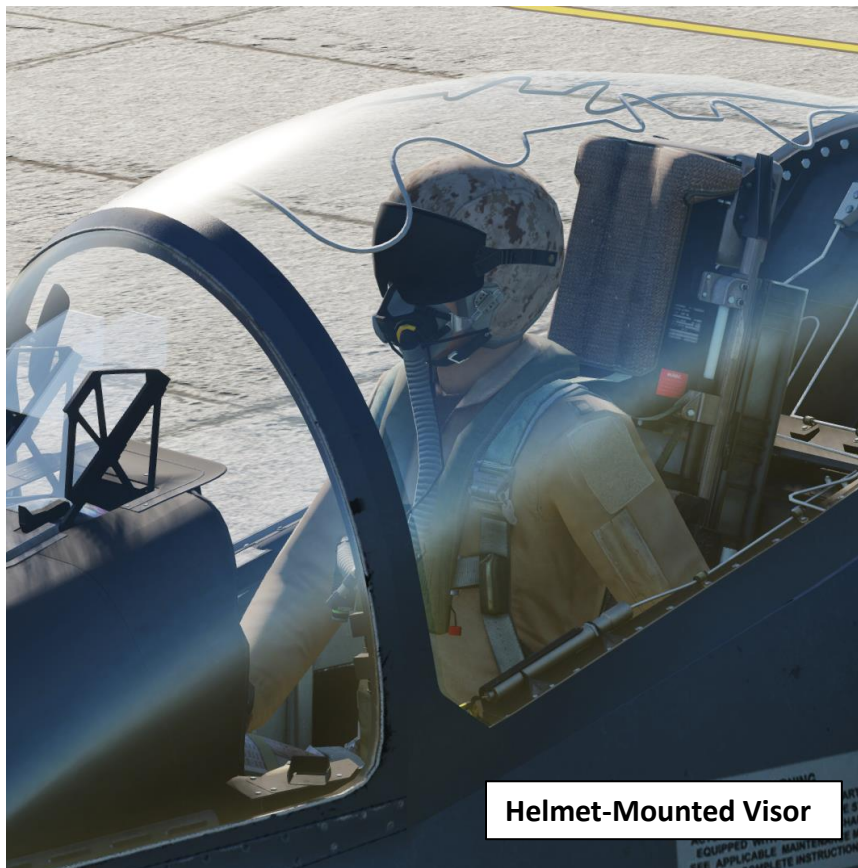

Helmet-Mounted Visor



Night Vision Goggles

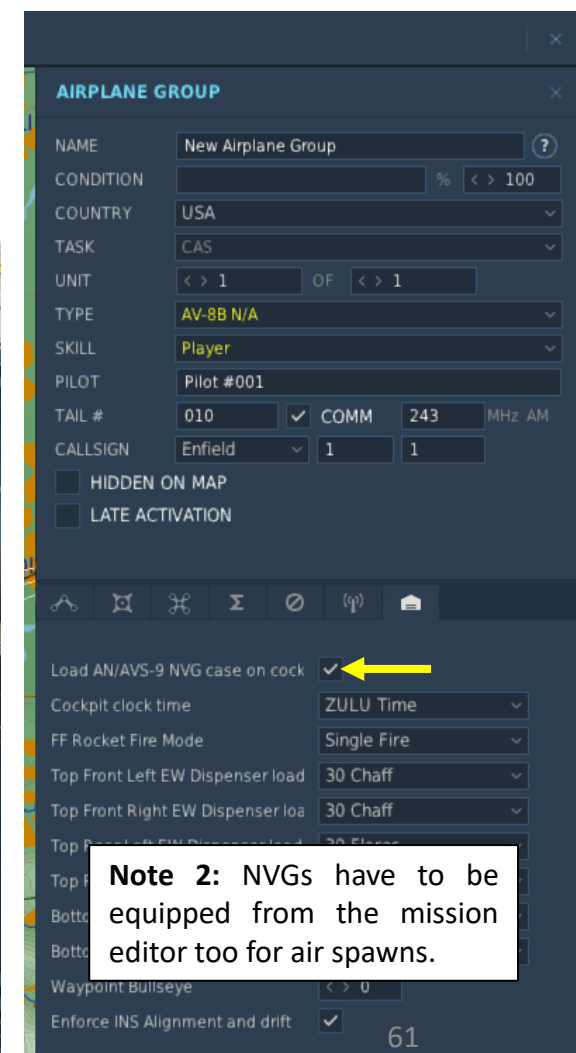

**Note 2:** NVGs have to be equipped from the mission editor too for air spawns.



**FLASHLIGHT CONTROL**  
ON/OFF: LALT + L



**NIGHT VISION GOGGLES**  
ON/OFF: LSHIFT + N  
NVG BRIGHTNESS DOWN: CUSTOM BINDING  
NVG BRIGHTNESS UP: CUSTOM BINDING

CONTROL OPTIONS		
AV8BNA	Pilot & Seat Controls	Reset category to default
Clear cat		
Action	Category	Keyboard
Eject (3 times)	Pilot & Seat Controls	LCtrl + E
Helmet Visor/NVG Toggle	Pilot & Seat Controls	LShift + N
Hide/Show Control Stick	Pilot & Seat Controls	RCtrl + RWin + S
Hide/Show Pilot Body	Pilot & Seat Controls	RCtrl + RWin + P
Hide/Show Throttle	Pilot & Seat Controls	RCtrl + RWin + T
Mirrors TOGGLE	Pilot & Seat Controls	LShift + M
NVG Brightness Down	Pilot & Seat Controls	
NVG Brightness Up	Pilot & Seat Controls	
Switch the Helmet Visor for NVG and viceversa	Pilot & Seat Controls	

## PRE-START-UP

1. Close and Lock Canopy. Confirm that CANOPY caution is extinguished.
2. LIDS (Lift Improvement Device System) Switch – NORM (AFT)
3. Oxygen Switch – ON (FWD)
4. SAS (Stability Augmentation System) Pitch Switch – ON (FWD)
5. SAS (Stability Augmentation System) Roll Switch – ON (FWD)
6. SAS (Stability Augmentation System) Yaw Switch – ON (FWD)
7. Q-Feel switch – ON (FWD)
8. Rudder Pedal Shaker (RPS/YAW) Switch – ON (MIDDLE)
9. Anti-Skid Switch – ON (MIDDLE)

1a – Set Locking Lever AFT (UNLOCKED)

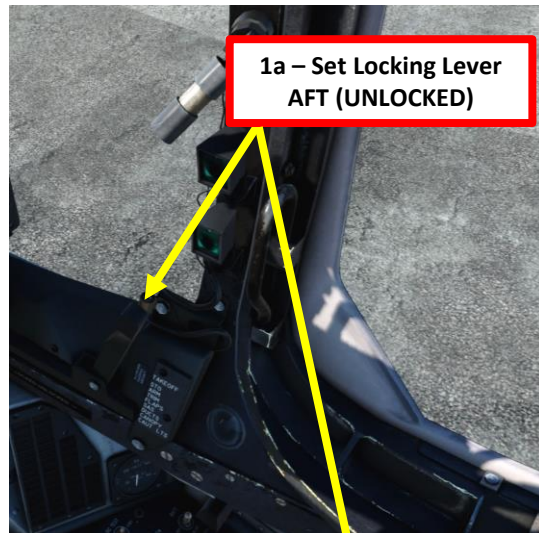

1b – Click on Canopy Handle to close canopy



1c – Set Locking Lever FWD (LOCKED)

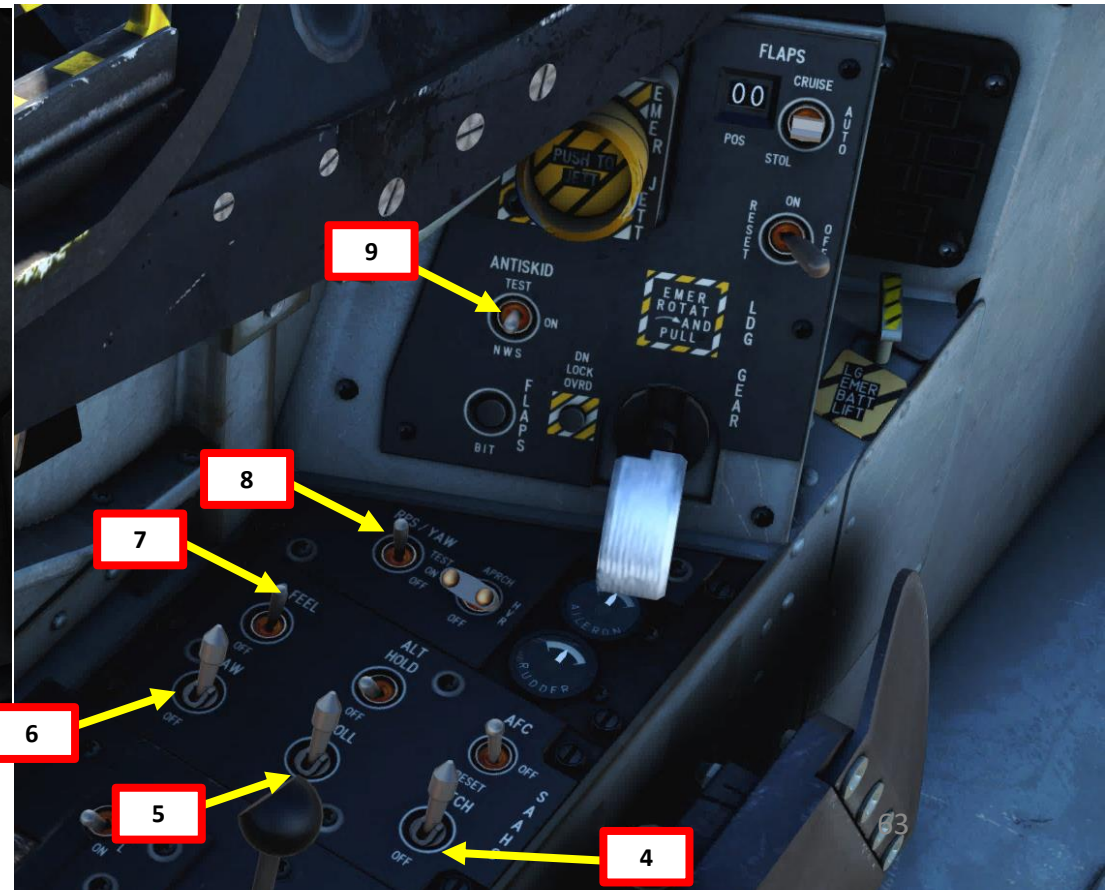
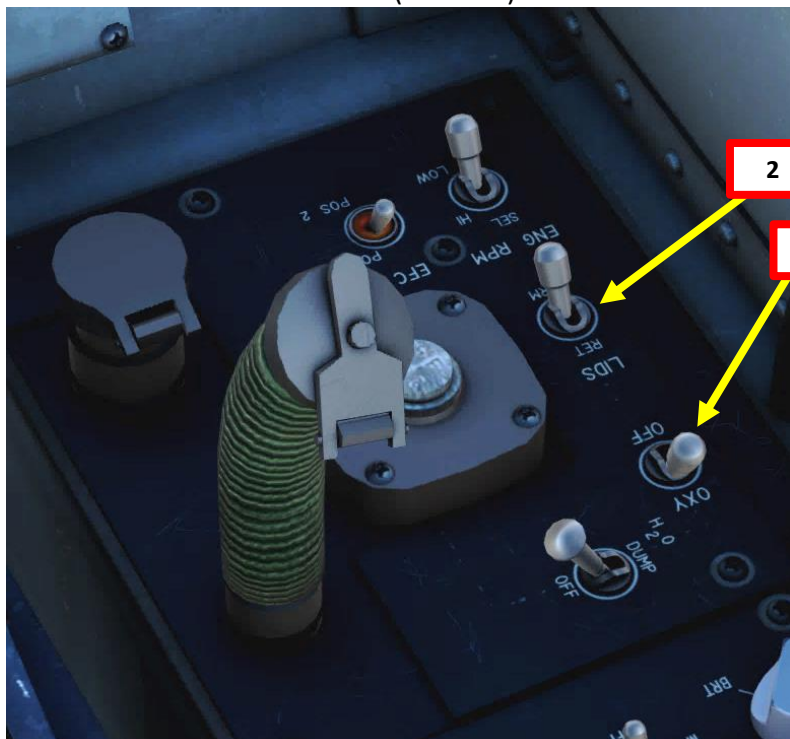

## START-UP PROCEDURE

The Harrier is equipped with a GTS (Gas Turbine Starter), also referred to as APU (Auxiliary Power Unit). Many aircraft use the APU to provide pneumatic pressure for the engine starter, but the Harrier uses an electrical starter instead.

The GTS serves a dual purpose: to provide electrical power when the engine main generators are OFF and to provide a starting mechanism for the engine. The GTS/APU has two operation modes:

- Mode 1: APU Generator Mode  
This mode is used on ground to recharge the battery and supply electrical power to avionics systems. This is achieved when the APU GEN switch is turned on.
- Mode 2: Starter Mode  
This mode is used to spool the engine electrical starter and is automatically selected by the ENG ST switch.

**DIRECT ENGINE START:** If the ENG ST (START) switch is held and the GTS/APU is not running, the GTS starts and accelerates to operating speed within 25 seconds. When the engine attains self-sustaining speed, the GTS automatically disengages and the engine start switch returns to OFF. If the GTS does not match operating speed within 25 seconds or the main engine is not self-sustaining within 40 seconds, the GTS automatically shuts down and the engine start switch returns to OFF.

**TRANSLATION ENGINE START** If the ENG ST (START) is held and the GTS/APU is already running in APU GEN mode, the APU generator drops offline, the APU switch automatically returns to OFF, the 40-second GTS shutdown protection circuit is activated and the main engine is automatically engaged for start.

Take note that the GTS/APU cannot run both modes at the same time. Additionally, if the APU is turned on before takeoff and the main engine-driven generator is operating, the APU will automatically shut down when the aircraft reaches 325 kts.

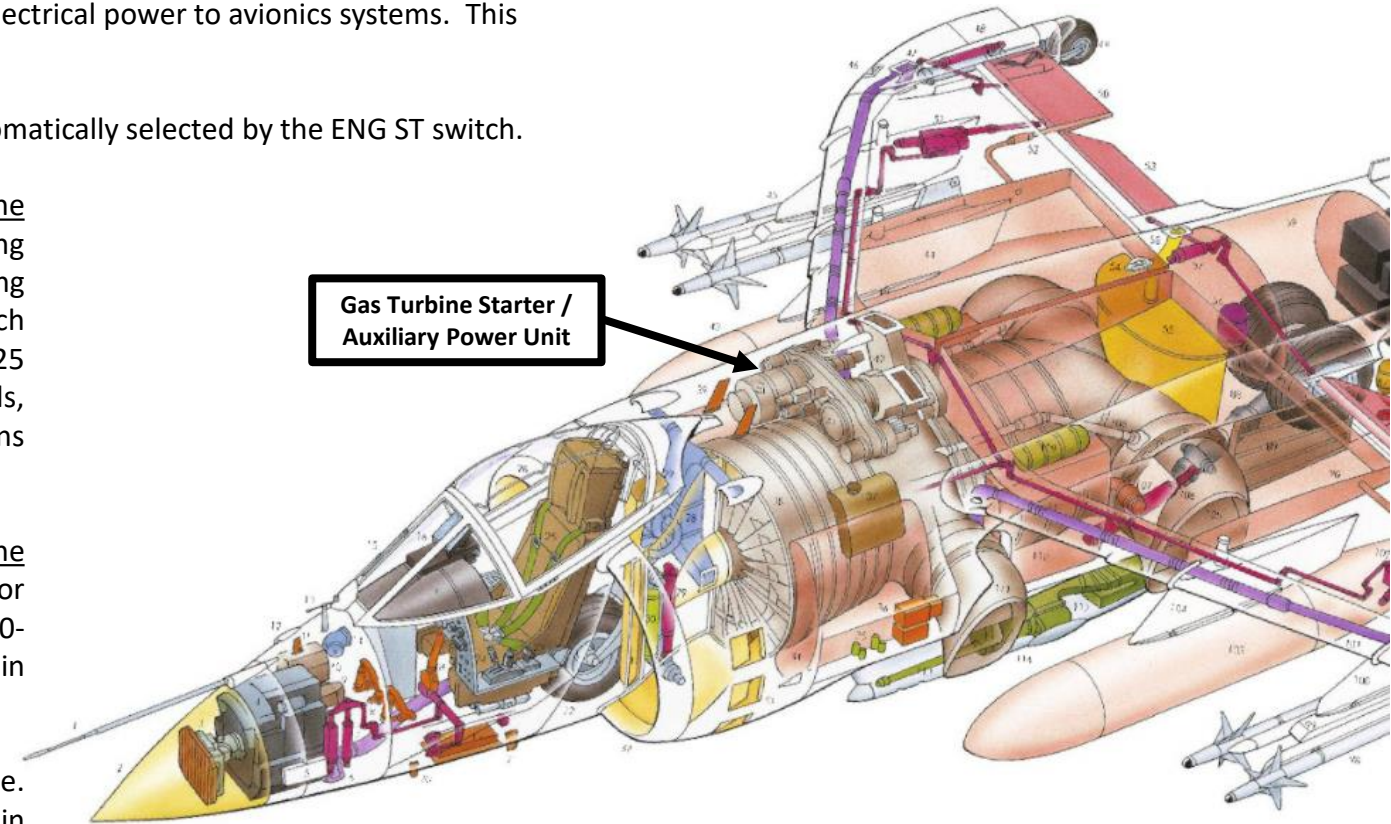

# START-UP PROCEDURE

1. Parking Brake Lever – ON (AFT)
2. Battery Switch – BATT (FWD)
3. Main Generator Switch – GEN (FWD)
4. Check that Voltmeter is at least 24.5 V
5. Engine RPM Switch – LOW
6. EFC (Engine Fuel Control) Switch – POS 2
7. Left/Right Boost Pump Switches – NORM (FWD)
8. Fuel Flow Proportioner – ON (FWD)
9. JPTL (Jet Pipe Temperature Limiter) Switch – ON (AFT)
10. Manual Fuel Switch – OFF (AFT)
11. Throttle – OFF (fully AFT)
12. Set Nozzle position lever – Between AFT and 10 deg
13. Fuel Shutoff Handle – ON (DOWN)
14. DECS (Digital Engine Control System) switch – ON

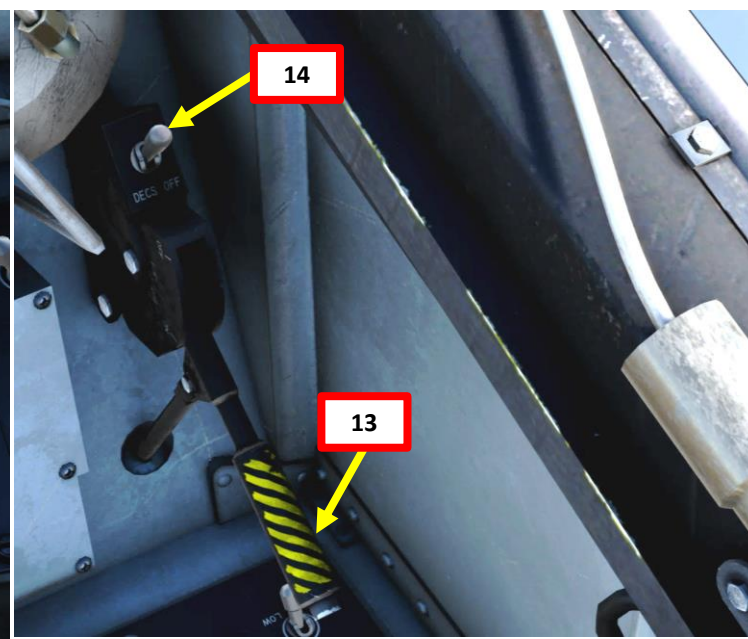
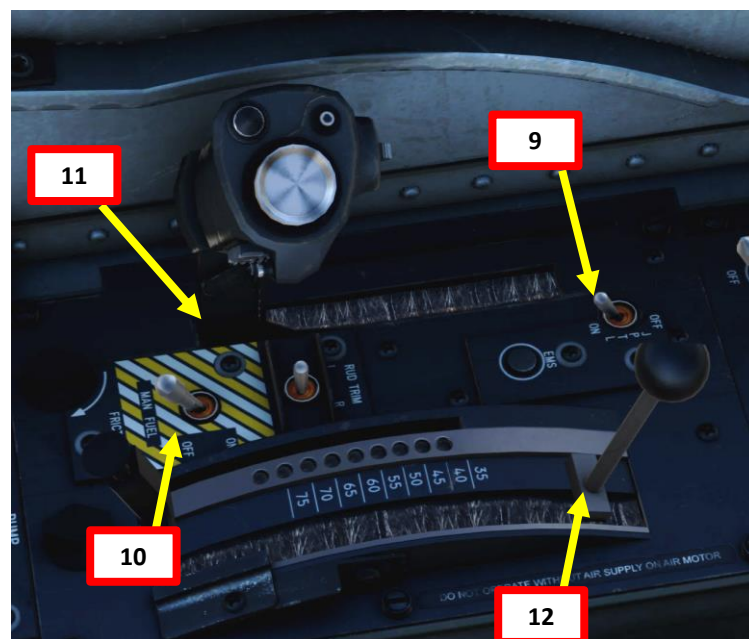
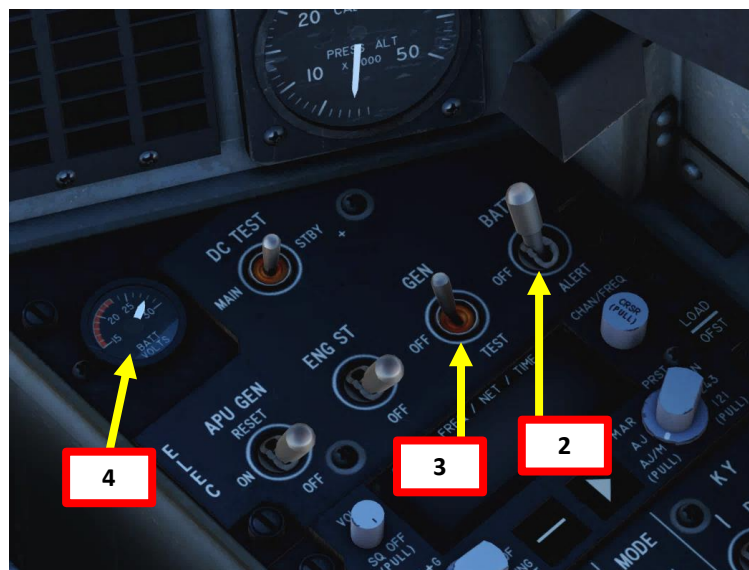
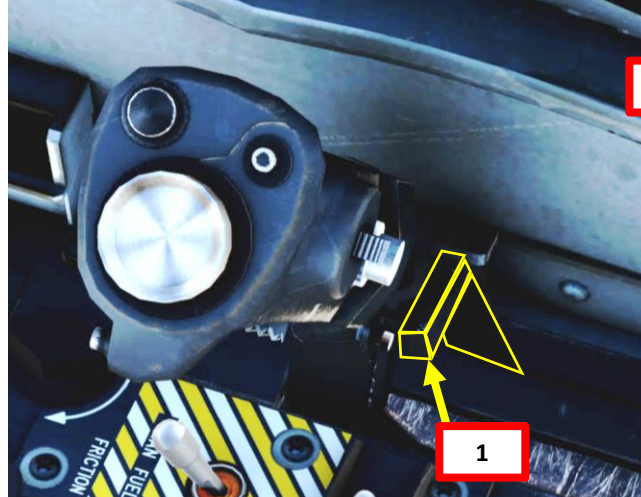

# START-UP PROCEDURE

- 15. *Optional:* APU GENERATOR switch – ON
- 16. *Optional:* Confirm that APU advisory is ON
- 17. *Optional:* Confirm that APU GEN light is OUT
- 18. Press the Master Warning Reset switch to get rid of the aural warning messages
- 19. Set Left and Right MPCD brightness knobs
- 20. Click on « ENG » OSB (Option Select Button) to set right MPCD to the Engine Data page

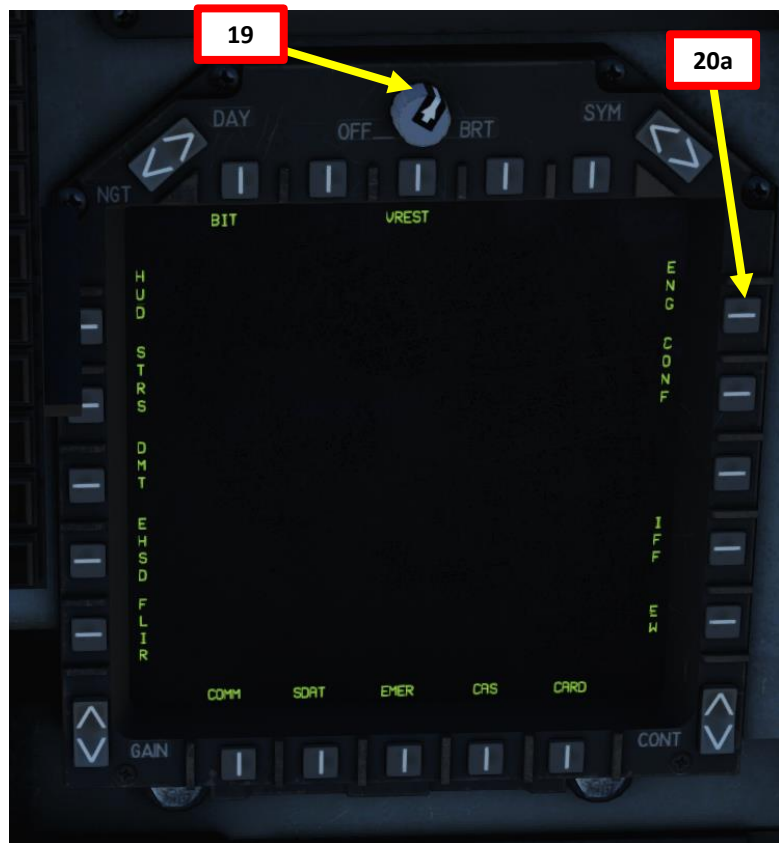
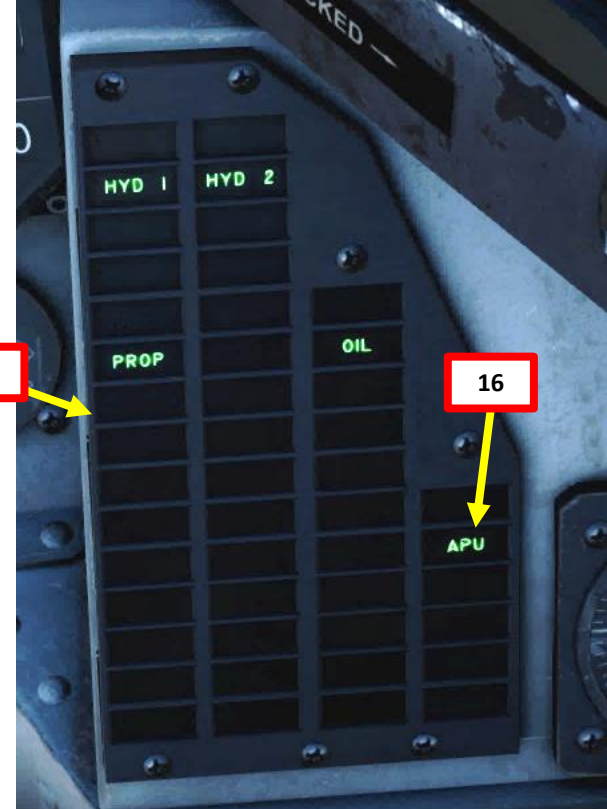

# START-UP PROCEDURE

21. Set Engine Start Switch – ENG ST
  - On a direct engine start (GTS/APU is OFF), the GTS normally lights off in about 5 seconds automatically, after which the engine begins to rotate.
  - On a translation engine start (GTS/APU is already started), there is a 10 second deceleration of the APU (Auxiliary Power Unit) before the GTS (Gas Turbine Starter) engages to start the engine.
22. Once engine RPM starts rising, move throttle lever forward to GROUND IDLE position. The throttle will mechanically stop at GROUND IDLE since the parking brake lever acts as a safety stopper.
23. Check that Engine Start switch automatically resets at OFF prior to 15 % RPM. If it doesn't, set it to OFF manually to prevent damage to the GTS.
24. Check that RPM stabilizes at IDLE RPM (between 28.4 and 29 % RPM)
25. Check that JPT (Jet Pipe Temperature) does not exceed 545 deg C.
26. Check that HYD 1 and HYD 2 Pressure stabilize at 3000 +/- 200 psi.
27. Check that brake accumulator Pressure stabilizes at 3000 +/- 200 psi.
28. Set Nozzle position lever to 10 deg (will prevent excessive wear on the tail plane and flaps due to the heat and jet efflux acting on those control surfaces)

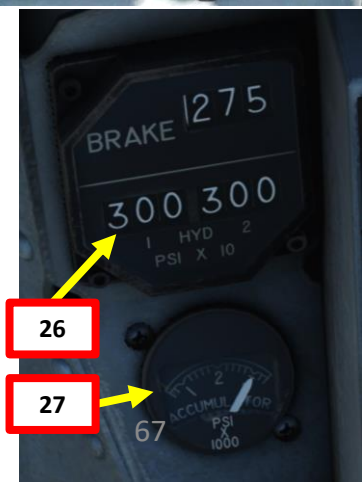
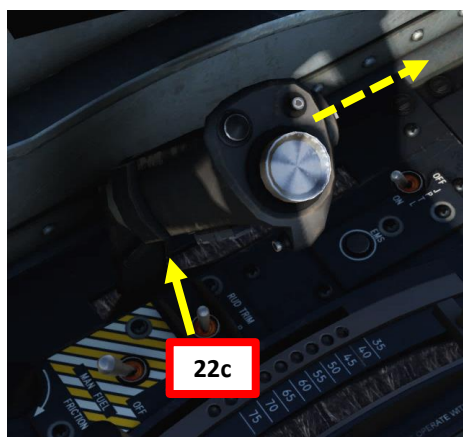
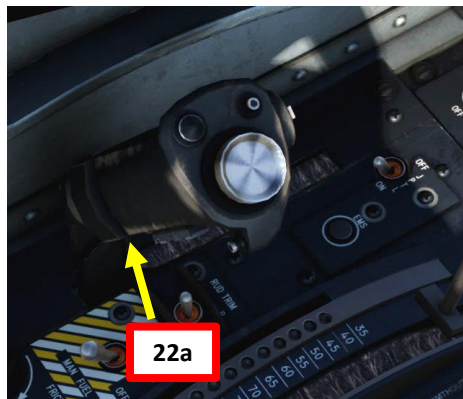
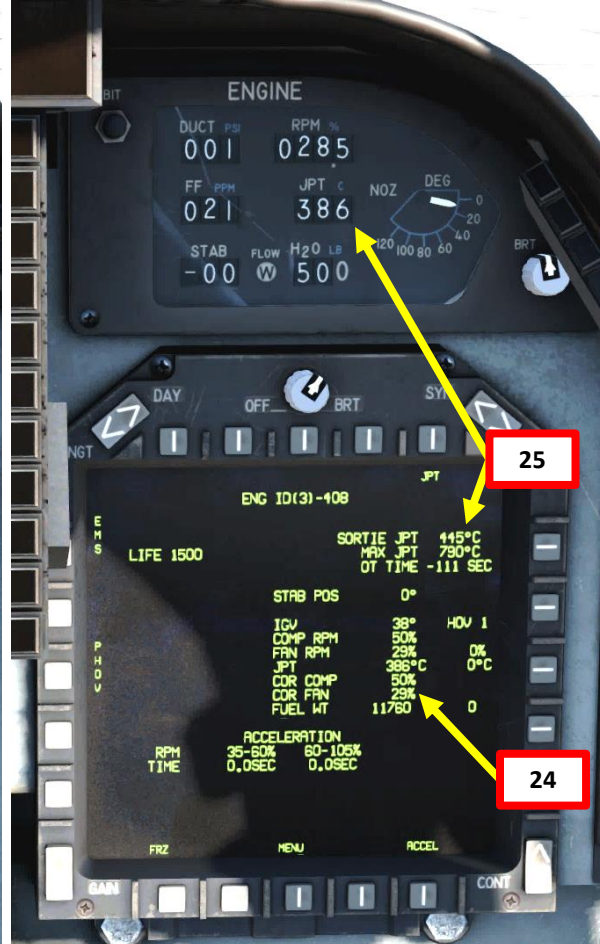

# START-UP PROCEDURE

29. Set Seat Ground Safety Lever – DOWN
30. Set Flaps Power Switch – ON (MIDDLE)
31. Set Flaps Mode Switch – CRUISE (UP)
32. Set RWR (Radar Warning Receiver) Switch – ON
33. Set EXP (Expendables Decoy Dispenser) Switch – AUTOMATIC
34. Set DECM (Defensive Electronic Countermeasure) Switch - STBY
35. Set left MPCD Brightness knob and click on « EHSD » OSB (Option Select Button) to set left MPCD to the Electronic Horizontal Situation Display page

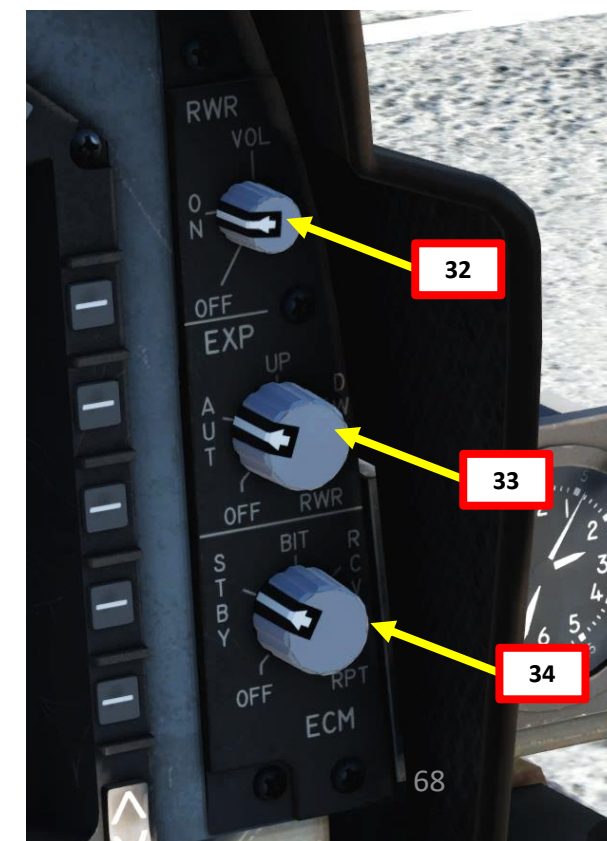
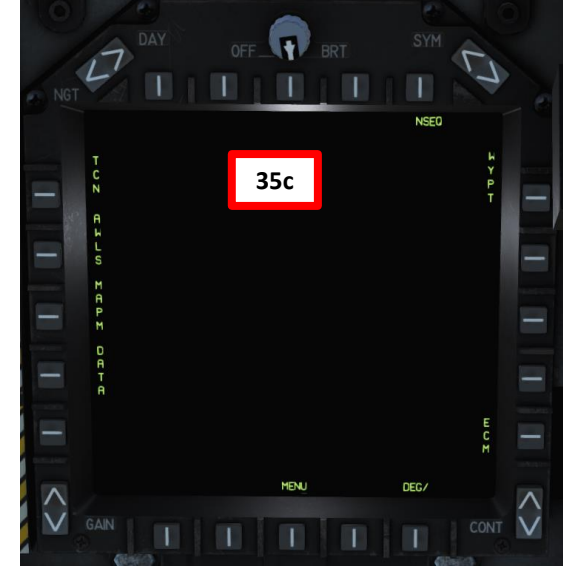
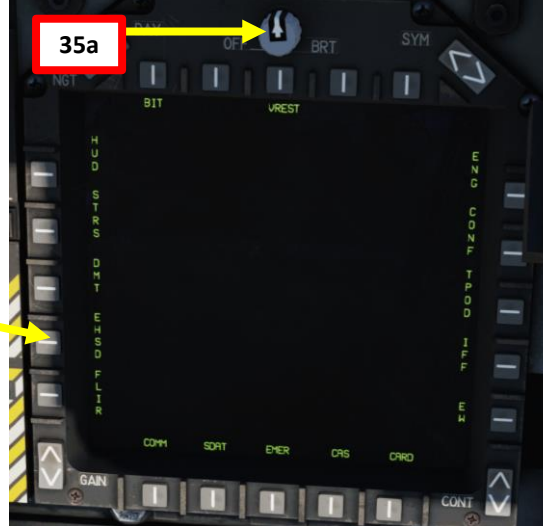

## INS ALIGNMENT OVERVIEW

The ASN-139 INS (Inertial Navigation System) has four **alignment modes**:

- **SEA**: alignment performed aboard a carrier by plugging in a SINS (Sea INS) cable. Uses the carrier's own inertial navigation system to achieve INS precision.
- **GND**: Ground mode can only be performed with the aircraft on land.
- **IFA (GPS)**: In-Flight Alignment uses the aircraft's built-in GPS (Global Positioning System). This alignment can be performed anywhere.
- **GYRO**: Degraded mode which provides a quick alignment process, but present position data is not available. This alignment can be performed anywhere.

Note: There are three INS **alignment sub-modes**:

- **SHDG**: (Stored heading alignment): Uses pre-existing heading for Ground & Sea modes, which accelerates alignment process.
- **Manual Sea Alignment**: performs a manual alignment without the carrier's SINS (Sea INS).
- **GPS airborne alignment**: available for IFA



**IMPORTANT: ALWAYS MAKE SURE YOUR PARKING BRAKE IS ENGAGED (LEVER AFT) DURING ALIGNMENT!**



**Before starting INS alignment, always make sure the INS Mode switch is set to OFF.**

## INS ALIGNMENT PROCEDURE OVERVIEW

The main alignment sequence is the same for all modes and sub-modes, times for each sequence is in parenthesis:

- a. **Cage (3 seconds)**: The INS is aligned with the aircraft fuselage.
- b. **Warm-Up (time depends on ambient temperature)**: Gyros and accelerometers are heated to their operational temperature of 170°F (76.67°C) at a rate of 2.5°F per second.
- c. **Spin (13 seconds)**: Gyros are spun up to 22,500 rpm.
- d. **Level (9 seconds)**: INS platform is leveled with respect of local vertical.
- e. **Wide Angle Gyrocompass (WAG) (time depends on alignment mode/sub-mode)**: INS determines True North to within about 2°.

The approximate time for WAG depends on alignment time:

- **GND**: 66 seconds.
- **SEA (SINS)**: 80 seconds.
- **SEA (manual)**: 240 seconds
- **IFA (Not moving)**: 80 seconds.

At this step the IMU is ready and a QAL number will be shown in the MPCD along with the word HDG.

- f. **Small Angle Alignment (SAA) (20 seconds)**: INS computes heading, tilts, and gyro mini-biases to the fine degree necessary. The beginning of SAA is indicated by the HDG legend displayed across from the QUAL digits on the MPCD.

### INS Alignment Procedure

#### All modes

1. Make sure that the INS mode selector is in the OFF position.
2. Select EHSD o the MPCD (either left or right).
3. Select DATA on the MPCD.
4. Select AC (aircraft data) on the MPCD.
  - a. Aircraft present position will be shown.
  - b. UFC/ODU will enter Aircraft Position mode.
  - c. The following ODU options are available:
    - i. Option 1: POS (Lat/Lon position coordinates).
    - ii. Option 2: MVAR (Local magnetic variation).
    - iii. Option 3: WIND (Wind Direction and Speed).
    - iv. Option 4: SHIP (Carrier heading and speed).
    - v. Option 5: THDG (Aircraft true heading).
5. Enter AC initial present position (IPP) latitude and longitude.
6. Enter local magnetic variation (MVAR) if the value shown is 0.
7. Place the INS mode selector in the selected alignment mode: SEA< GND, IFA or GYRO. The alignment process will start immediately if the required data has been entered.
8. When the alignment is finished place the INS mode selector knob either in NAV (for degraded mode navigation) or IFA (for GPS coupled navigation).



# INS ALIGNMENT OVERVIEW

The difference between UNALIGNED, SAVED HEADING ONLY and PRE-ALIGNED is what data is already available in the INS when starting the alignment.

- **UNALIGNED:** You have to input IPP (Initial Present Position) data, magnetic variation and align the INS.
- **SAVED HEADING ONLY:** You still have to align the INS, but present position data is already in the system and you can bypass one of the steps. It has a faster alignment period.
- **PREALIGNED:** The INS is aligned from the get go.

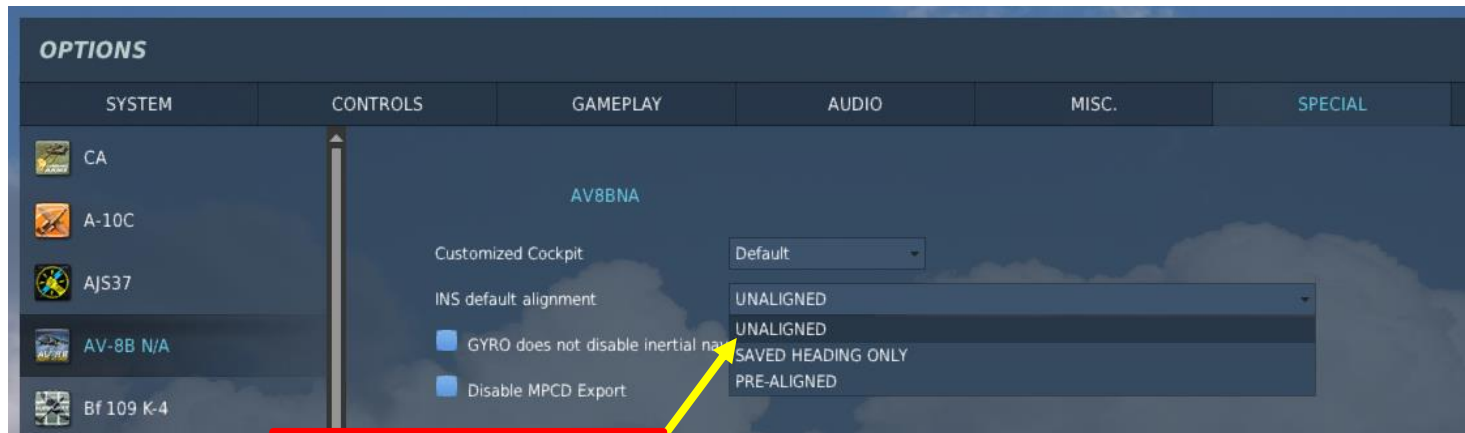

Alignment options: unaligned, saved heading, or pre-aligned.

Unaligned  
(Requires alignment on IPP)

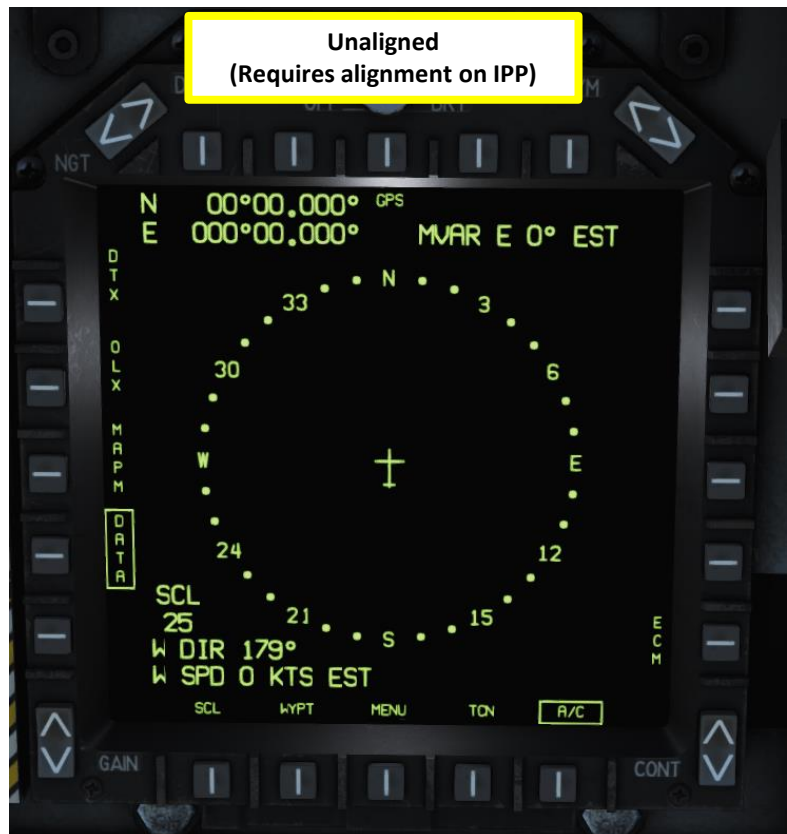

Saved Heading Only  
(Requires alignment on IPP)



Pre-Aligned  
(Does not require alignment on IPP)



# INS ALIGNMENT (GROUND)

36. Set IPP (Initial Present Position) if the aircraft is not pre-aligned, then start GND INS (Inertial Navigation System) alignment phase. Steps preceded by « \* » are not required if the « PRE-ALIGNED » option is ticked in the Special Options tab.

- Make sure parking brake is engaged
- Set DISPLAY Brightness Knob to BRT
- \* Select MENU->EHSD->DATA->A/C menu on the MPCD.
- \* Press « RSHIFT+K » to open up kneboard and check your Initial Position. Write down your coordinates (i.e. **42°14'35" North 42°02'14" East** in deg, min, sec) and magnetic variation (**6.2 deg East**). Keep in mind that the coordinate input to the Up-Front Controller is in deg, min, sec, while the displayed coordinate format on the EHSD is in deg, min decimals.

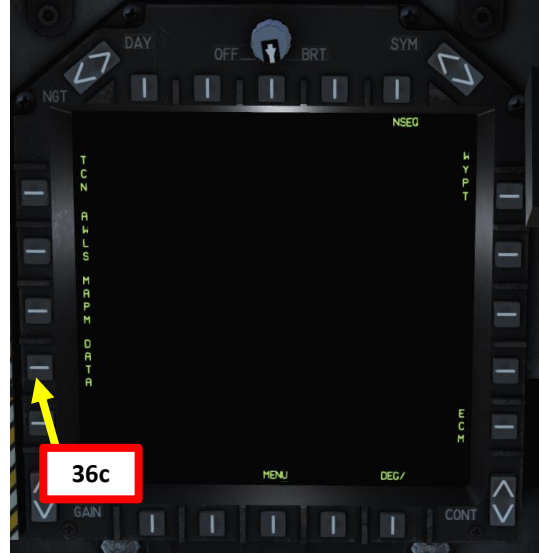

**AV-8B NIGHT ATTACK WORKSHEET**

GAU-12 Gun Pod: **LOADED**  
 Gun Ammo: **300 ROUNDS**  
 FF Rocket Fire Mode: **SINGLE**  
 RS + RA + [0]  
 AN/AVS-9 NVG Case: **RS + RA + [9]**

**WARNING:**  
 VALUES CAN ONLY BE  
 MODIFIED WHEN THE  
 ENGINE IS OFF

STATION	1	2	3	4	5	6	7
WEAPON				0L	I	K	N
NUMBER	1	1	1	1	1	1	1

**ECM Dispenser Pod:**

1. Top Front Left:	30 CHAFF	RS + RA + [1]
2. Top Front Right:	30 CHAFF	RS + RA + [2]
3. Top Rear Left:	30 FLARES	RS + RA + [3]
4. Top Rear Right:	30 FLARES	RS + RA + [4]
5. Bottom Left:	30 FLARES	RS + RA + [5]
6. Bottom Right:	30 FLARES	RS + RA + [6]

**Initial Position**

1. Latitude:	42 : 14 : 35 N	← 36d
2. Longitude:	042 : 02 : 14 E	
3. Altitude:	49 FEET	
4. Mag Var:	6.2 E	



## INS ALIGNMENT (GROUND)

36. Set IPP (Initial Present Position) if the aircraft is not pre-aligned, then start GND INS (Inertial Navigation System) alignment phase. Steps preceded by « \* » are not required if the « PRE-ALIGNED » option is ticked in the Special Options tab.

- d) \* Press « RSHIFT+K » to open up kneeboard and check your Initial Position. Write down your coordinates (i.e. **42°14'35" North** **42°02'14" East** in deg, min, sec) and magnetic variation (**6.2 deg East**). Keep in mind that the coordinate input to the Up-Front Controller is in deg, min, sec, while the displayed coordinate format on the EHSD is in deg, min decimals.
- e) \* Press the POS (Position) ODU (Option Display Unit) to select the coordinate Latitude (":" will appear next to it when selected).
- f) \* On the UFC, press « 2 » (N) to select North coordinates, type « **421435** », then « ENT » to enter them.
- g) \* Press on the POS ODU again to select the coordinate Longitude.
- h) \* On the UFC, press « 6 » (E) to select East coordinates, type « **0420214** », then « ENT » to enter them. Don't forget to add the 0 at the beginning.
- i) \* Enter the correct MVAR (Magnetic Variation) based on where you are. Press the ODU next to MVAR (":" will appear next to it when selected), press « 6 » (E) to select East coordinates, and then type « **6.2** », then « ENT » to enter the magnetic variation of 6.2 East deg.

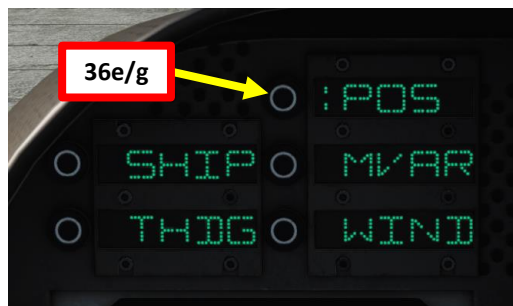
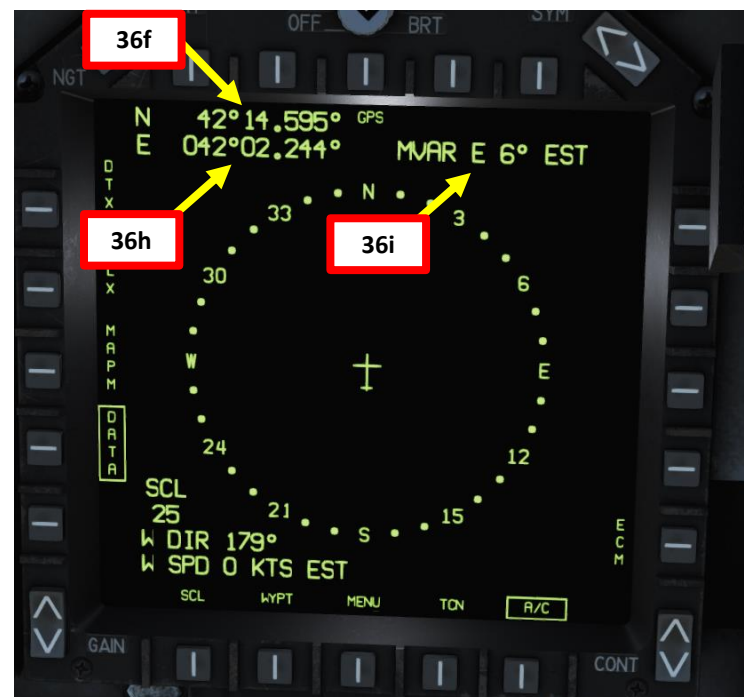

# INS ALIGNMENT (GROUND)

36. Set IPP (Initial Present Position) if the aircraft is not pre-aligned, then start GND INS (Inertial Navigation System) alignment phase. Steps preceded by « \* » are not required if the « PRE-ALIGNED » option is ticked in the Special Options tab.

- j) Set INS mode switch to ALIGN GND INS.
- k) During the first 1 to 2 minutes of alignment, the indicator has ATT NOT OK displayed to the right of QUAL (Alignment Quality).
- l) Once the message QUAL 0.7 OK appears, you can consider your alignment to be complete.
- m) Set INS mode switch to IFA (In-Flight Alignment coupled with GPS).

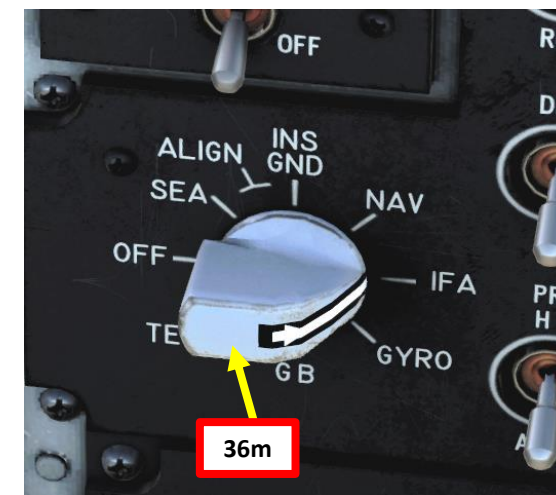

# INS ALIGNMENT (SEA/SINS)

36. Start INS (Inertial Navigation System) alignment phase by connecting the SINS (Sea INS) data cable to the aircraft. Then, start SEA INS (Inertial Navigation System) alignment phase.

- a) Make sure parking brake is engaged
- b) Set DISPLAY Brightness Knob
- c) Select MENU->EHSD->DATA->AC menu on the MPCD.

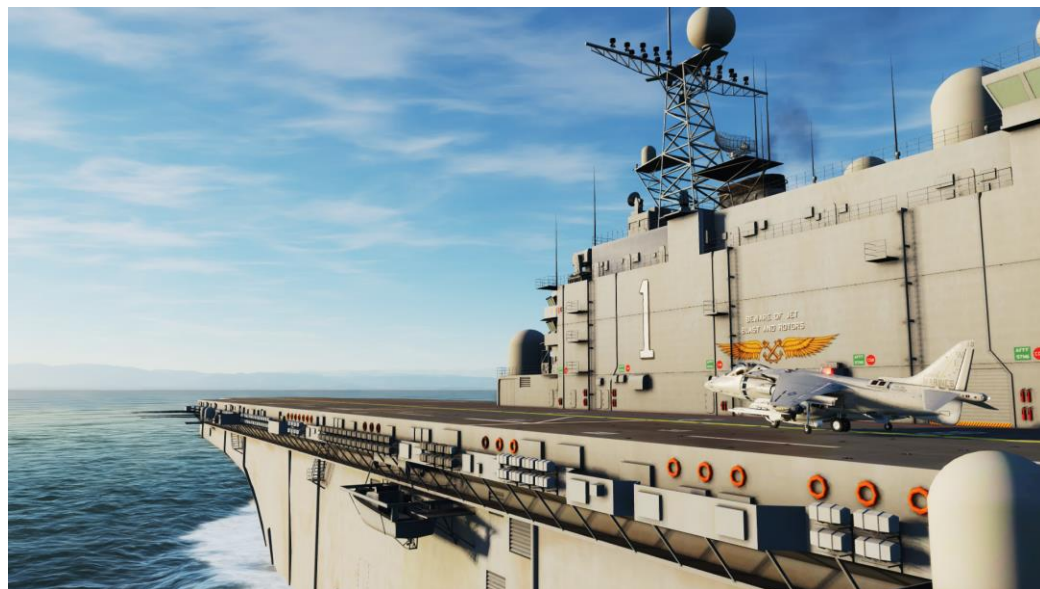
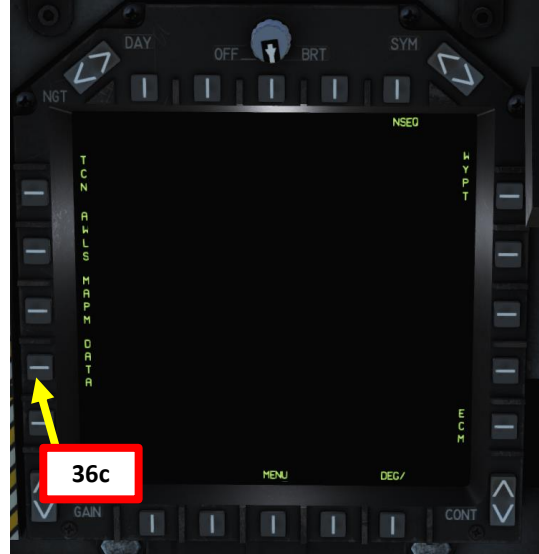

# INS ALIGNMENT (SEA/SINS)

36. Start INS (Inertial Navigation System) alignment phase by connecting the SINS (Sea INS) data cable to the aircraft. Then, start SEA INS (Inertial Navigation System) alignment phase.

- d) Contact ground crew and request electrical power by pressing « \ », then pressing F8 (Ground Crew), F2 (Ground Electric Power), then F1 (ON).
- e) Electrical power will be applied and SINS (Sea INS) data cables will be connected from the carrier's INS system to the aircraft.
- f) Set INS mode switch to ALIGN SEA INS (SINS).
- g) During the first 1 to 2 minutes of alignment, the indicator has ATT NOT OK displayed to the right of QUAL (Alignment Quality).
- h) Once the message QUAL 0.7 OK appears, you can consider your alignment to be complete.
- i) Set INS mode switch to IFA (In-Flight Alignment coupled with GPS).
- j) Remove ground power / disconnect SINS cable.

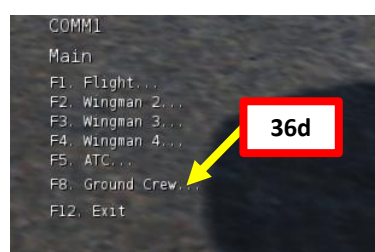

36d

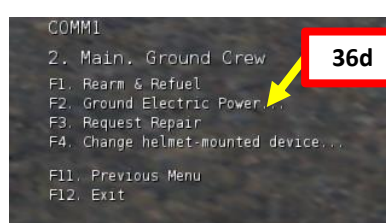

36d

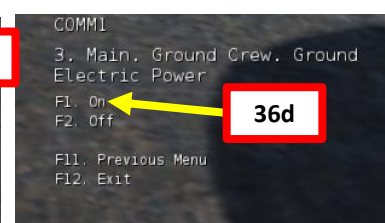

36d



36e

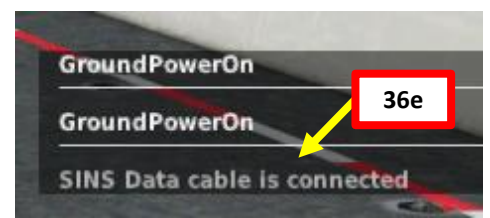

36e



36f



36i



36g



Alignment in progress



36h

Alignment complete

**COMPLETE AIRCRAFT SET-UP**

- 37. Set Radio 1 & 2 Volume Knobs
- 38. Set COMM1 and COMM2 Radios to desired frequencies
- 39. Set HUD SYMBOLOGY Brightness Knob
- 40. Set HUD VIDEO Brightness Knob
- 41. Set HUD VIDEO Contrast Knob
- 42. On the EHSD menu, unselect the DATA menu.
- 43. Set FLIR Switch – ON (UP)
- 44. Set DMT (Dual Mode Tracker) Switch – ON (UP)
- 45. Set PROBE HEAT switch – AUTO

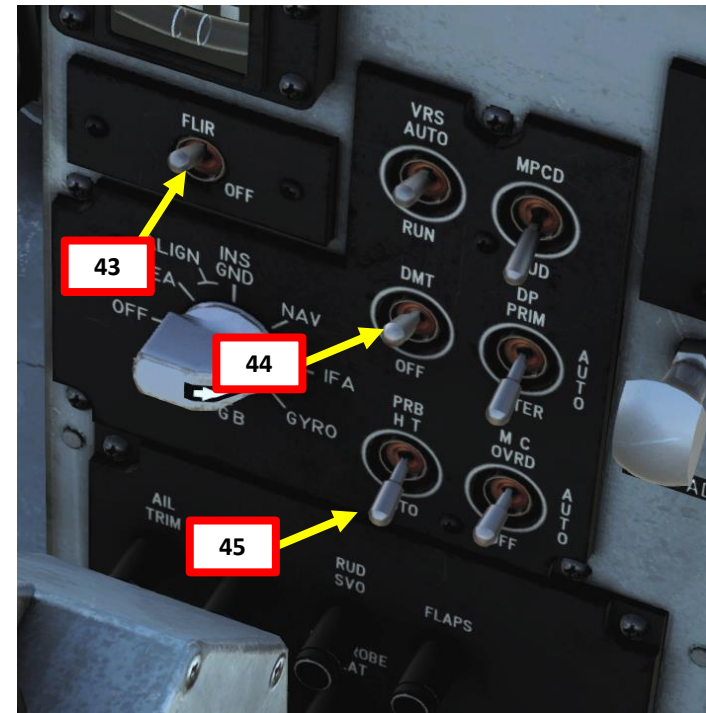

# COMPLETE AIRCRAFT SET-UP

46. Press ALT button on UFC (Up-Front Control)
47. Turn on radar altimeter by pressing the « ON/OFF » button on the UFC.
48. Set ALT switch – RDR (Radar Altimeter)
49. Set GPWS (Ground Proximity Warning System) – As desired (« : » means active)
50. On the UFC, type « 4900 », then press « ENT » to enter a Low Altitude Warning of 4900 ft.
51. Make sure GPS is selected (“:” means active). This will allow GPS altitude for ballistic computations.
52. Remove Wheel Chocks
  - a) Make sure your canopy is open to communicate to the ground crew
  - b) Press “\” (communication menu binding) to contact ground crew
  - c) Press “F8” to select “Ground Crew”
  - d) Press “F4” to select “Wheel Chocks”
  - e) Press “F2” to “Remove Wheel Chocks”.

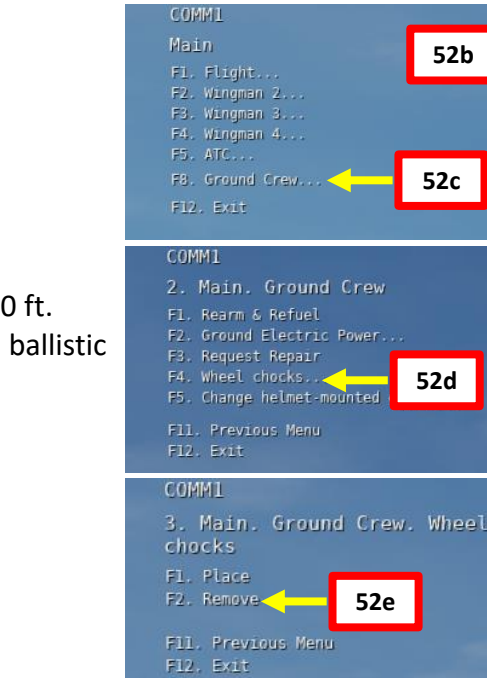

## TAKEOFF TUTORIAL STRUCTURE

1. Taxi
2. Takeoff Principles
3. Takeoff Types
4. Conventional Takeoff (CTO)
5. Short Takeoff (STO)
6. Vertical Takeoff (VTO)
7. Rolling Vertical Takeoff (RVTO)
8. Ship Takeoff

**1 - TAXI**

1. Ensure Anti-Skid Switch is set to ON (Middle Position), and flaps are ON (MIDDLE position) and at CRUISE (UP position), and Nozzle angle is at 10 deg
2. Select VSTOL (Vertical Short Takeoff & Landing) Master Mode Switch
3. Set trim to 0 deg rudder, 0 deg aileron, and 4 deg stabilator nose down.
4. Release Parking Brake Lever (FWD)
5. Throttle up to taxi

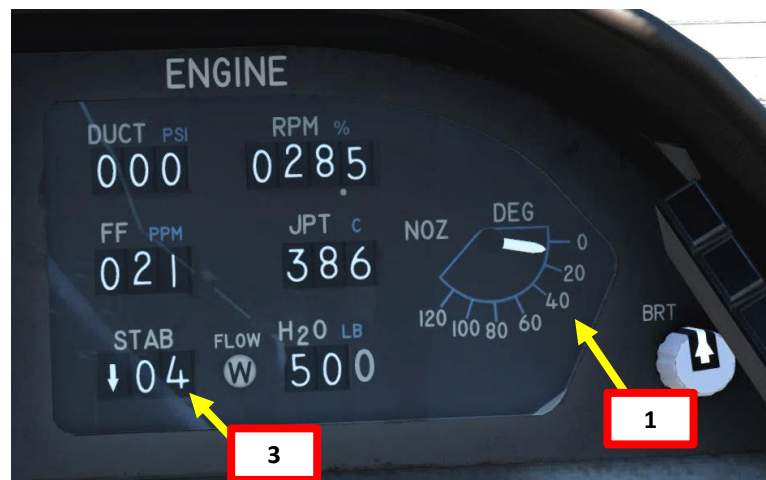

Click on the spot behind the throttle to release parking brake



1 - TAXI

6. If you need to slow down, set Nozzle Control Lever between 45 and 60 degrees to better control taxi speed
7. Press and hold the « AG Target Undesignate/NWS/FOV Toggle) » HOTAS button (LWIN + N key binding by default) and use your rudder pedals to steer the aircraft.

**Nosewheel Steering (NWS) Modes (NWS HOTAS Button):**

- **CASTER:** Nose wheel is free to swivel, and rudder pedal movement is isolated from the NWS system.
- **LOW GAIN:** Rudder pedals are connected to the system, with a range of movement between +/- 14 deg
- **HIGH GAIN:** Rudder pedals are connected to the system, with a range of movement between +/- 45 deg. HI GAIN is undesirable above 20 kts ground speed due to poor directional control characteristics. This is used mainly on very tight spaces like on a carrier.

**Anti-Skid Modes (ANTISKID Switch):**

- **TEST:** Test Mode
- **ON:** Anti-Skid ON (*NWS CASTER Mode by default, NWS LO GAIN when NWS HOTAS button is pressed*)
- **NWS:** Anti-Skid OFF (*NWS LO GAIN Mode by default, NWS HI GAIN when NWS HOTAS button is pressed*)

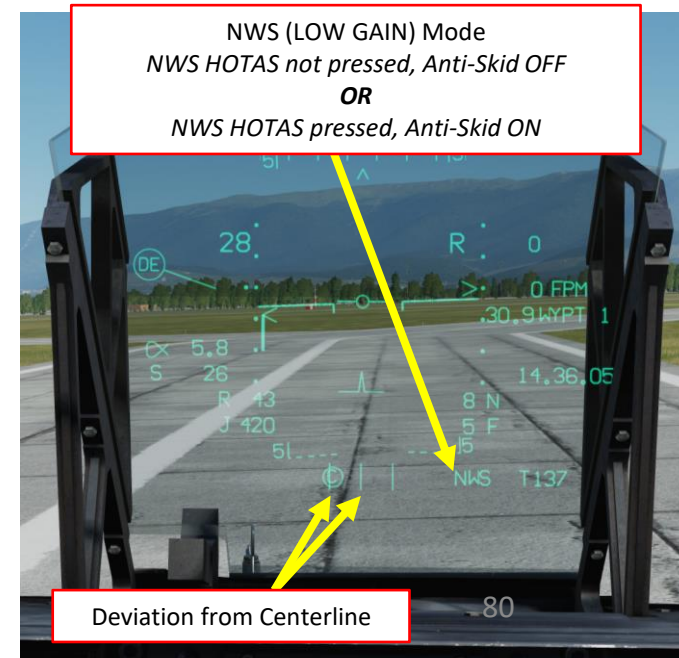
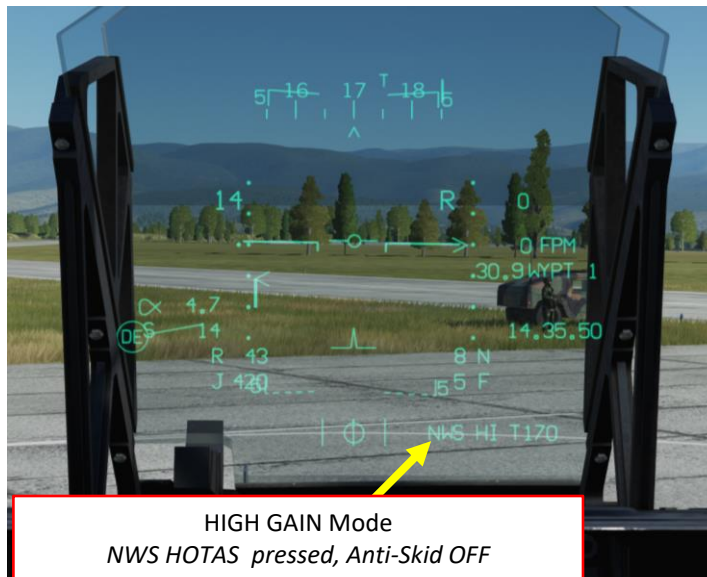
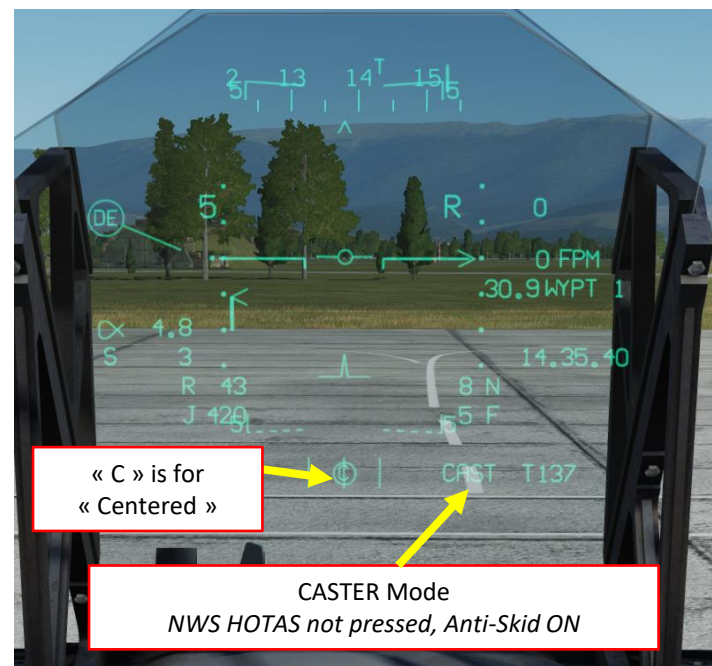

## 2 - TAKEOFF PRINCIPLES

Taking off and landing in the Harrier is one of the most interesting part of the aircraft: you can takeoff using a conventional method, but you can also takeoff vertically or perform a rolling takeoff depending on how much runway you have available or if you are operating on a FARP (Forward Arming & Refueling Point), an aircraft carrier or an amphibious assault ship like the LHA-1 USS Tarawa.

Taking off in real life requires performance charts to estimate various parameters like the Nozzle Rotation Airspeed (NRAS). The A1-AV8BB-NFM-400 (NATOPS FLIGHT MANUAL PERFORMANCE CHARTS) document gives you charts and graphs to calculate everything you need.

Don't gasp in horror like that, we won't go as deep. I'll just give you some ballpark figures to get you up to speed without having to do much performance calculations.

### SAMPLE VERTICAL TAKEOFF CAPABILITY

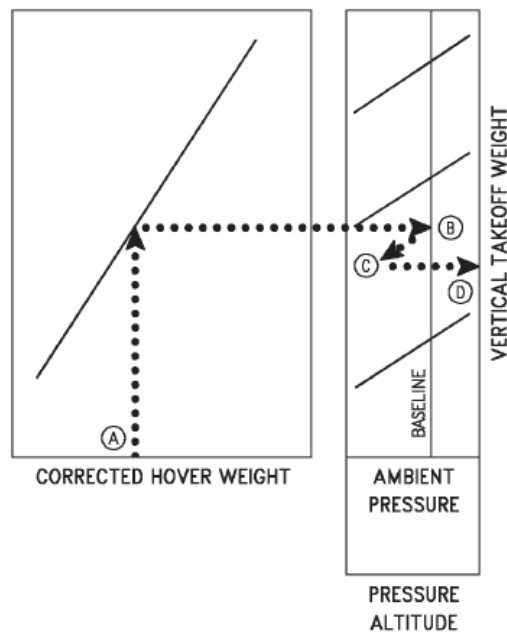

### SAMPLE ROLLING VERTICAL TAKEOFF CAPABILITY

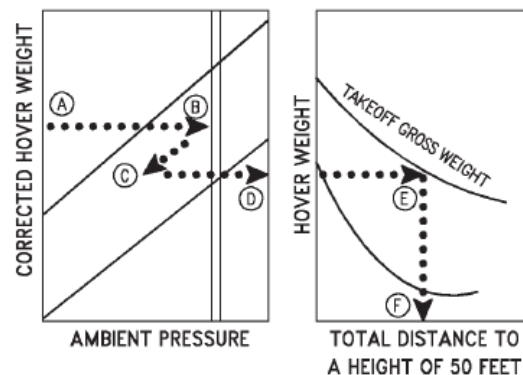

### SAMPLE SHORT TAKEOFF ROTATION SPEED

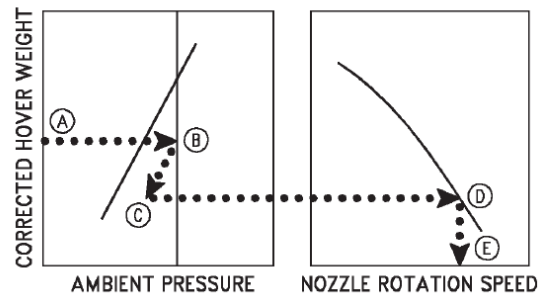

### SAMPLE CONVENTIONAL TAKEOFF DISTANCE

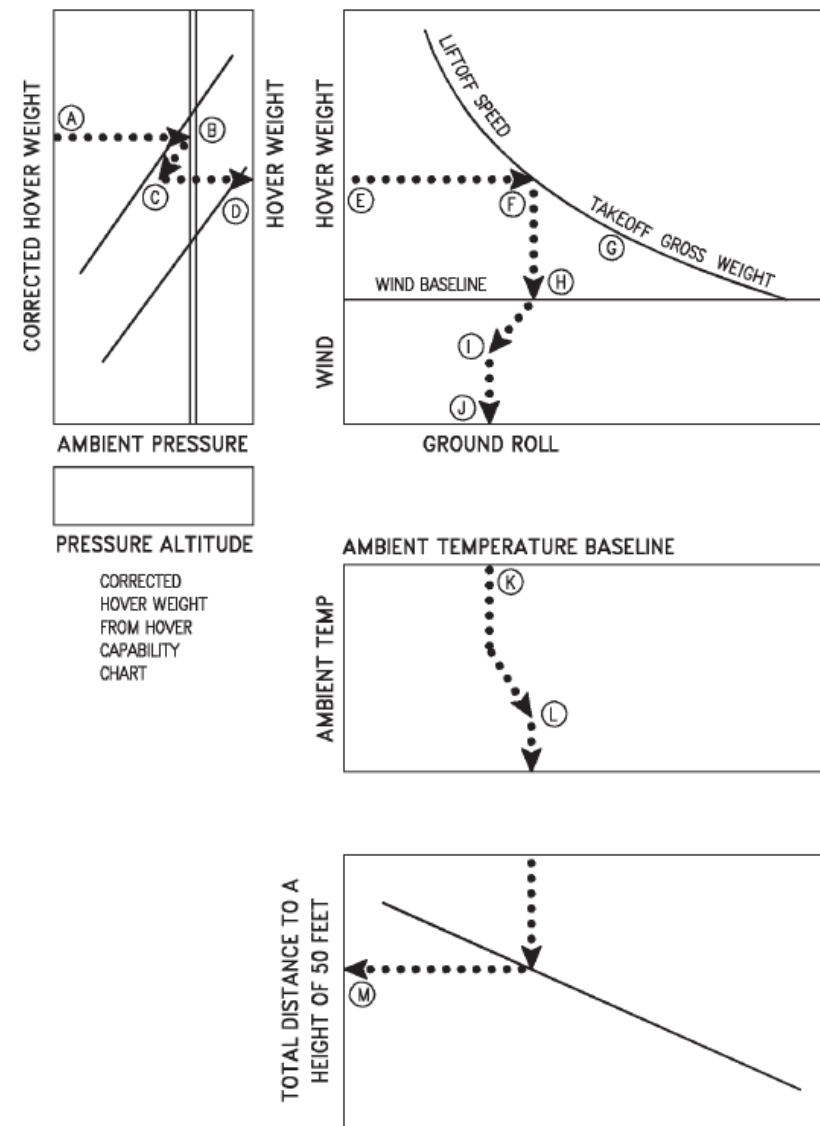

# 2 - TAKEOFF PRINCIPLES

Flyco on the Eagle Dynamics forums graciously produced a data sheet giving representative data for takeoff. This is accurate only for Standard Temperature and Pressure (ISA, or 29.92 in Hg/1013,25 hPa and 15 degrees C).

### Performance

Best Climb Speed 300 kts > 0.78M  
Penetration 280 kts

### Diversion

Climb @ 300 kias to Cruise Ht shown Cruise @ MN shown Descend @ 230 kias

Fuel remaining at bottom of descent 800 lbs (200 lbs for Vert Ldg + 600 lbs reserve)

Fuel Remaining	1000 lbs	1500 lbs	2000 lbs	3000 lbs
Climb to Height	5,000 ft	30,000 ft	44,000 ft	44,000 ft
Cruise at	0.40 M	0.62 M	0.78 M	0.75 M
Total Range	17 nm	84 nm	178 nm	357 nm

### AV-8B – DATA & LIMITATIONS

**Aircraft Weights** ZFW – 13,537 lbs Max Int Fuel & Water – 21,737 lbs  
Max Wt – 31,086 lbs Max Ldg Wt – 26,000 lbs

**Limiting Speeds** Max - 585 kias, 1.0 M Gear - 250 kias Flaps - 300 kias 0.87 M

**Engine Limits** Max Continuous 102 % 645 °C

		15 secs	1½ mins	2½ mins	10 mins	15 mins
Wet	RPM	120 %	116%			
	JPT	800 °C	780 °C			
Dry	RPM	113.5 %		111 %	111 %	109 %
	JPT	780 °C		765 °C	750 °C	710 °C

**Take-Off Data** All at Standard Temperature & Pressure (STP)

Hover Power for Weight

Weight lbs	14000	16000	18000	20000	20,755
RPM	100.4 %	104.3 %	108.3 %	113.5 %	116.0 %
JPT	627 °C	667 °C	707 °C	758 °C	780 °

Short Take-Off

Weight	18,000	20,000	24,000	28,000	30,000	31,000
NRAS	77 kts	81 kts	88 kts	96 kts	98 kts	101 kts
Nozzle	60 °	60 °	60 °	60 °	55 °	50 °
Distance	550 ft	610 ft	750 ft	850 ft	970 ft	1100 ft

Conventional Take-Off

Weight	18,000	20,000	24,000	28,000	30,000	31,000
Lift-off Speed	135 kts	135 kts	139 kts	153 kts	160 kts	164 kts
Distance						

**Landing Data** At STP

Conventional Landing

Weight	18,000	20,000	24,000	28,000	30,000	31,000
Threshold Speed	142 kts	135	135	139	175 kts	183 kts
Distance	5200 ft				8500 ft	



### 3 - TAKEOFF TYPES

**Conventional Takeoff (CTO):**

The CTO can be used when configuration or environmental conditions preclude use of any other takeoff type (i.e. crosswinds or asymmetric loadings). The CTO is restricted to gross weights that will not cause the wheel/tire limitation speed of 180 KGS (Knots, Ground Speed) to be exceeded on the takeoff roll.

**Short Takeoff (STO):**

The STO can be used for the widest variety of aircraft configuration, weight and runway conditions provided that crosswinds remain within specified limits.

**Vertical Takeoff (VTO):**

Vertical Takeoff is perfect when you have less than 100 ft of available takeoff distance, like in a FARP (Forward Arming Refueling Point) or a FOB (Forward Operating Base). However, the limiting factor is the aircraft weight; you are more limited in the type/amount of payload the aircraft can carry. As much as possible, vertical takeoff should be performed into the wind. Lateral control during the first few feet of a VTO is critical; do not hesitate to make immediate, large and rapid control movements to counteract bank angles.

**Rolling Vertical Takeoff (RVTO):**

The RVTO requires approximately 100 feet of ground roll and should be made as nearly into the wind as possible.

### Takeoff Crosswind Restrictions

Conventional (CTO)	20 kts (Day or Night)
Short (STO) > 120 kts	15 kts (Day or Night)
Short (STO) <= 120 kts	10 kts (Day or Night)
Rolling Vertical (RVTO)	Day: 10 kts Night: 5 kts
Vertical (VTO)	10 kts (Day or Night)



# 4 - CONVENTIONAL TAKEOFF (CTO)

1. Press the V/STOL Master Mode button to colonize the ODU (Option Display Unit) with V/STOL (Vertical/Short Takeoff & Landing) options.
2. Select ODU button next to NRAS (":" means selected), then enter "135" on the UFC scratchpad, then press "ENT". Nozzle Rotation Airspeed (NRAS) is not used for conventional takeoff, but the NRAS setting will box the HUD airspeed indicator when the aircraft has reached the entered NRAS speed. In our case, 135 kts is our rotation speed on takeoff.
3. Select ODU button next to PC, or "Pitch Caret" (":" means selected), then verify that "14 deg" is the value displayed on the UFC scratchpad, then press "ENT". This means the Pitch Carets are placed 6 deg above the horizon, where we will seek to place the Depressed Attitude Indicator / Witch's Hat for an accelerating transition into a positive rate of climb.
4. Since we will do a conventional takeoff on a pretty long runway, we will skip the use of the VREST page to calculate the Abort Speed (ASPD) and Stopping Distance (SDST). This will be further explored in the Short Takeoff tutorial.

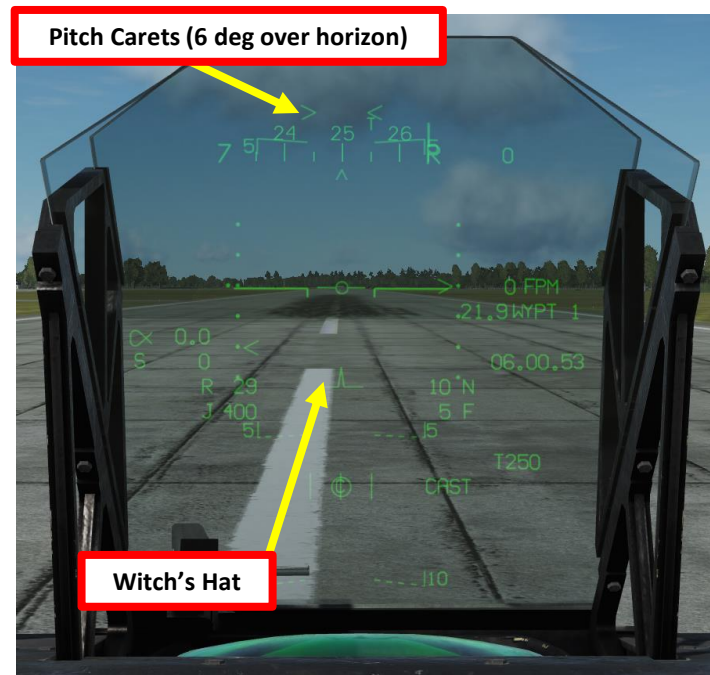

# 4 - CONVENTIONAL TAKEOFF (CTO)

5. Set STO STOP stopper fully AFT (CLEAR)
6. Set Nozzle Position Lever – 10 deg
7. Flaps Lever – AUTO
8. Set H2O Water Injection Switch – TAKEOFF (UP)
9. Set Stabilator Trim to Takeoff Trim (2 deg nose down)
10. Check that Anti-Skid Switch is ON
11. Hold Brakes

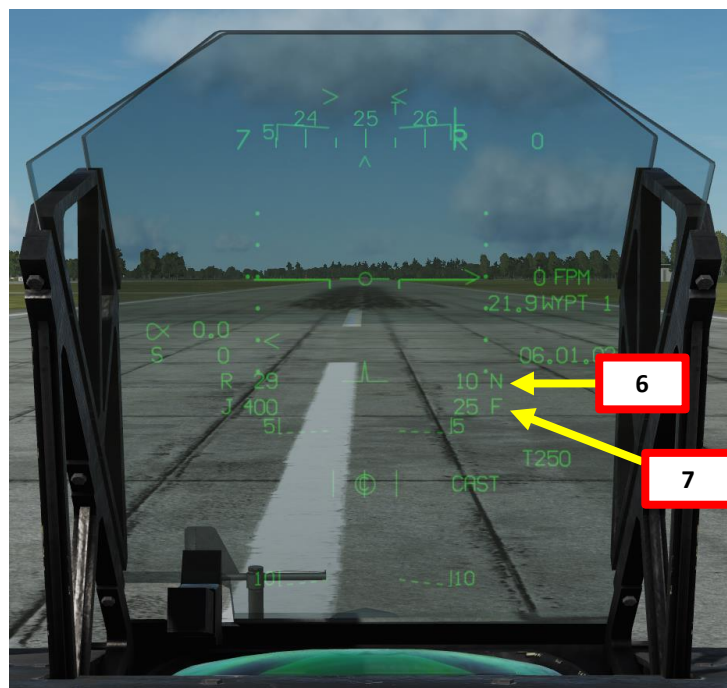
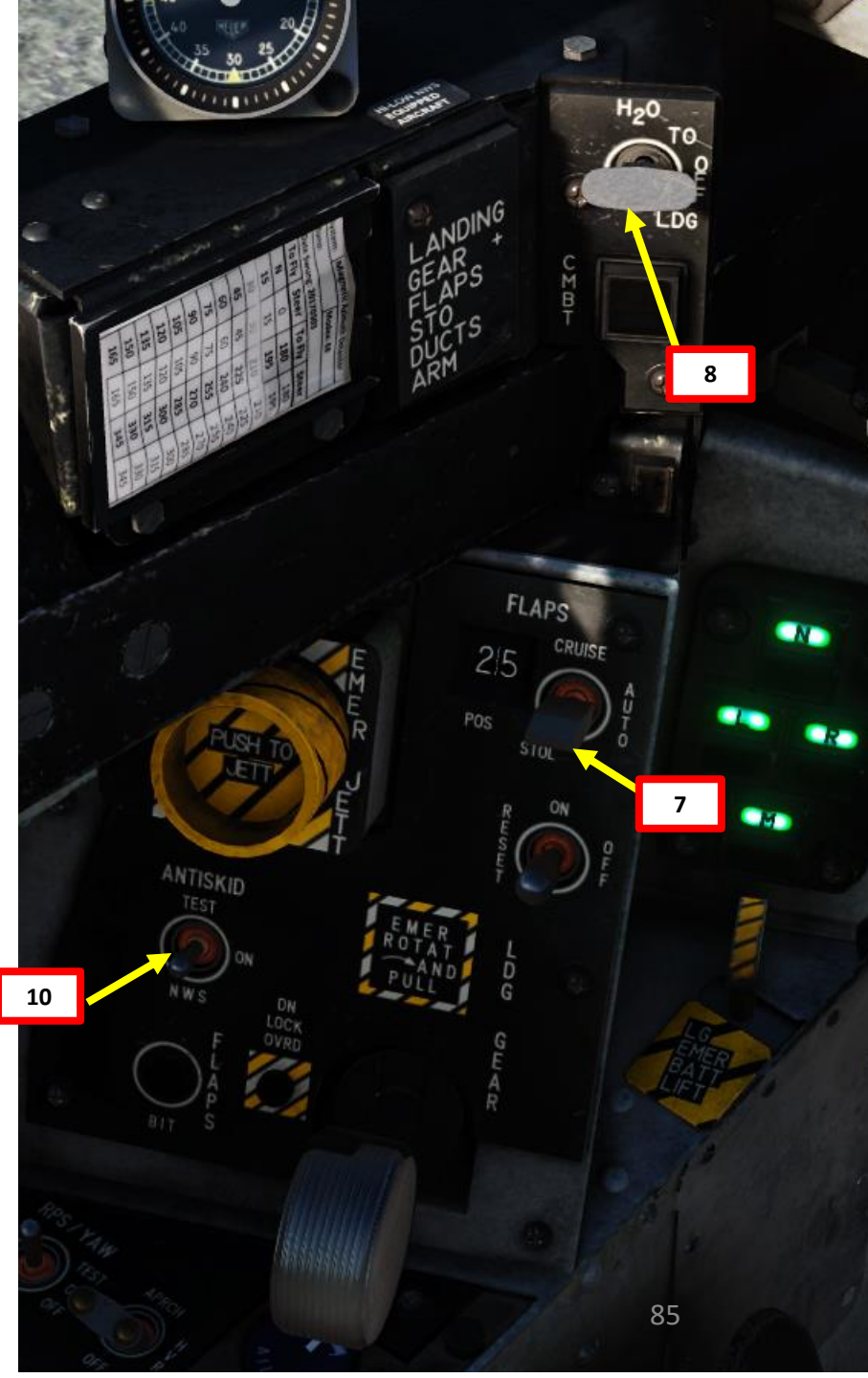
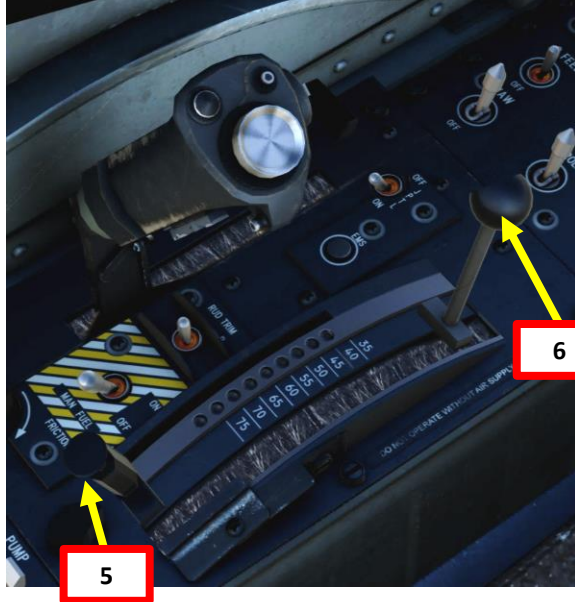

## 4 - CONVENTIONAL TAKEOFF (CTO)

12. Throttle up (make sure the limit icon does not go to FULL) and press the NWS HOTAS button to line up the aircraft with the center of the runway if need be
13. You will begin to have aerodynamic control of the rudder at 50-60 kts
14. Rotate very gently at around 135 kts
15. During liftoff, ensure wings remain level and center the sideslip vane to takeoff into the wind
16. Set aircraft attitude: line up Witch Hat with the Pitch Carets (currently set to a fixed value of 14 deg, or 6 deg elevation above horizon line).
17. After liftoff, set landing gear lever UP
18. Gradually set Nozzles to 0 deg
19. Set Water H2O Water Injection Switch – OFF (MIDDLE)

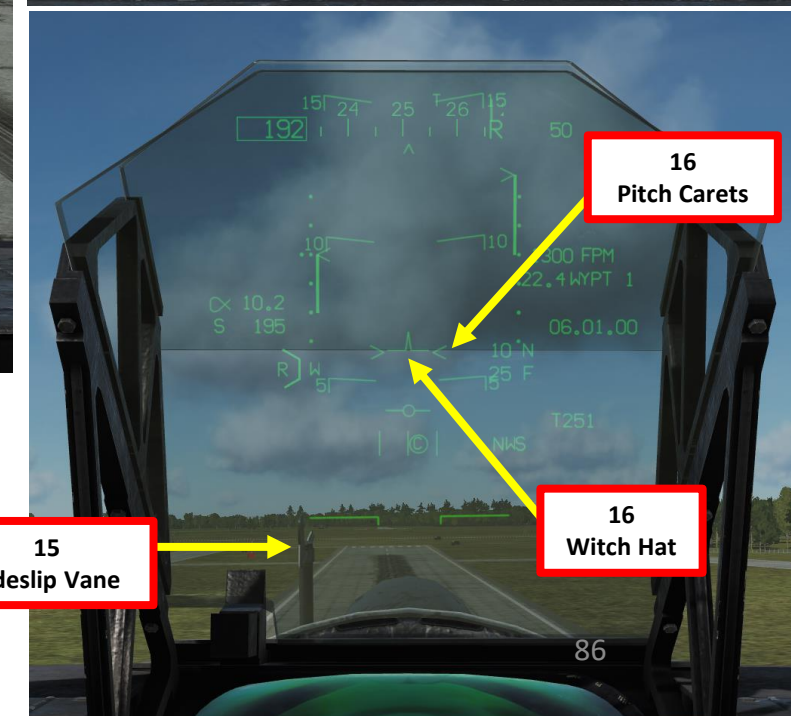
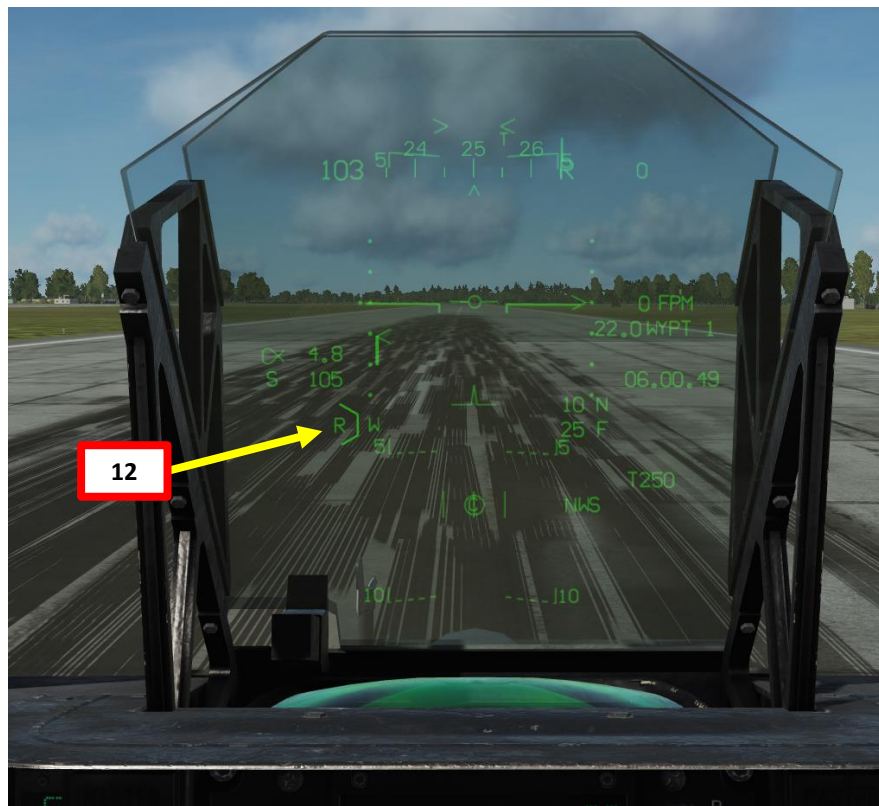

4 - CONVENTIONAL TAKEOFF  
(CTO)

CHECK THE ENGINES SECTION  
TO KNOW MORE ABOUT  
ENGINE OPERATION & LIMITS

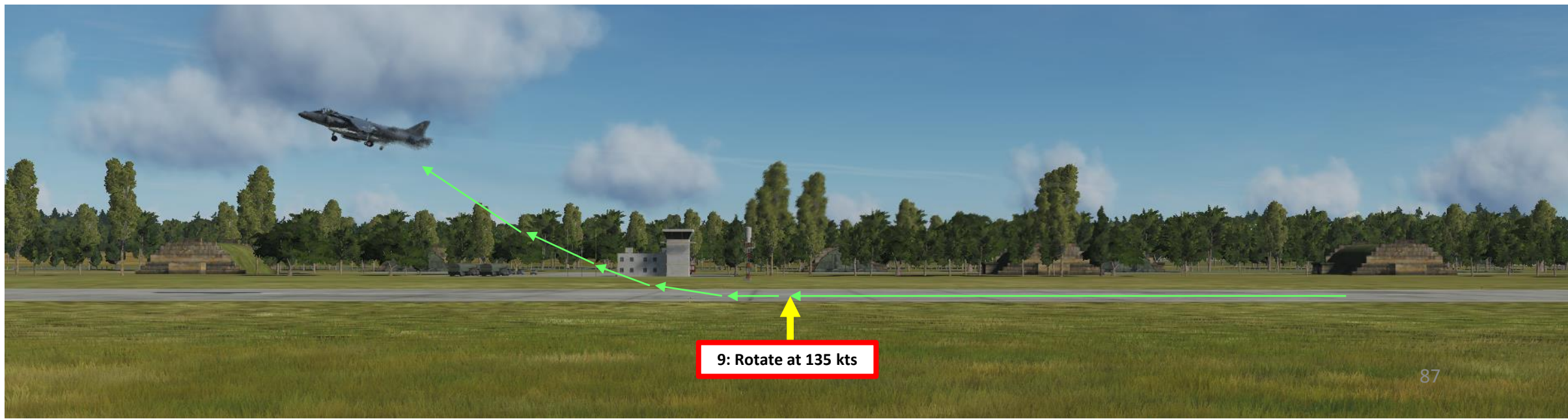

# 5 - SHORT TAKEOFF (STO)

1. First, we need to gather the following information:
  - a) **Runway Length (7870 ft)**, obtained by using "RSHIFT+K" to open kneeboard, and "[" and "]" to find the page for the desired airport (Kobuleti in our case)
  - b) **Runway Magnetic Heading (244 Magnetic for Runway 25)**
  - c) **Field Elevation (59 ft)**
  - d) **Barometric Pressure Setting (29.67 in Hg)**, obtained by contacting tower on the radio and requesting takeoff clearance
  - e) **Wind information (Magnetic Heading/Speed is 160 deg/ 009 kts)**, given in the Mission Briefing page).



**WEATHER**

- Temperature +26°
- QNH 755 / 29.72
- Cloud cover Base 600
- Nav Wind At GRND 5 m/s, 160°
- At 2000m 8 m/s, 243°
- At 8000m 7 m/s, 71°
- Turbulence 1.2 m/s

**Coordinates:**

P1	41°55.717' N	041°51.232' E	Holding Position N
P2	41°55.665' N	041°51.249' E	Holding Position C
P3	41°55.867' N	041°52.345' E	Holding Position B
P4	41°56.032' N	041°52.547' E	Intersection TWY N / P

**Runway Information Table:**

RWY	TORA	TODA	ASDA	LDA	PSN THR	ALS
07	7870 [ft] 2400 [m]	7870 [ft] 2400 [m]	7870 [ft] 2400 [m]	7870 [ft] 2400 [m]	41°55.640'N 041°50.975'E	☺
25	7870 [ft] 2400 [m]	7870 [ft] 2400 [m]	7870 [ft] 2400 [m]	7870 [ft] 2400 [m]	41°55.952'N 041°52.642'E	☺

**Other Chart Data:**

FAIR	07-25	A B C D E	259-0.8 200 (200-0.8/1.6) 05 3'	ARP	41° 55.797' N	ELEV	59 [ft]
SRA	07-25	A B C D E	469-1.2 350 (350-1.2/1.6)		041° 51.809' E		18 [m]

**Additional Chart Data:**

Tower	Radar	Final - Precision	TACAN	ILS RWY 07
133.000 MHz			67X "KBL"	111.50 MHz

**Scale:** 1:18'000

**Scale Bar:** 0 200 400 600 [ft]

**Scale Bar:** 0 300 600 1500 2000 [m]

**TERPS AERODROME CHART**

**KOBULETI (UG5X)**

Press « RSHIFT+K » to open up kneeboard and use « [ » and « ] » to find the Aerodrome Chart.

# 5 - SHORT TAKEOFF (STO)

2. Make sure the V/STOL Master Mode button is active and the VREST page is accessible from the MPCD main menu, then select VREST (Vertical/Short Takeoff & Landing, Range, Endurance , Speed & Time) page.
3. Press OSB next to "STO" to select "Short Takeoff" sub-page.
4. Select FELV (Field Elevation) ODU, enter 59 ft on the UFC, then press ENT.
5. Select FDAT (Field Data) ODU. ":" means it is selected.
6. Select RDIS (Runway Distance) ODU, enter 7870 on the UFC, then press ENT.
7. Select RHDG (Runway Heading) ODU, enter 244 on the UFC, then press ENT.
8. Select GWND (Ground Wind) ODU, enter 160/009 on the UFC, then press ENT.
9. Select RDRY (Runway Dry/Wet State) ODU: Dry = ":" or Wet = Empty.
10. Adjust Barometric Pressure Setting to 29.67 in Hg.



Runway Length: 7870 ft  
 Runway Magnetic Heading: 244  
 Field Elevation: 59 ft  
 Barometric Pressure Setting: 29.67 in Hg  
 Wind Magnetic Heading/Speed: 160 deg/ 009 kts

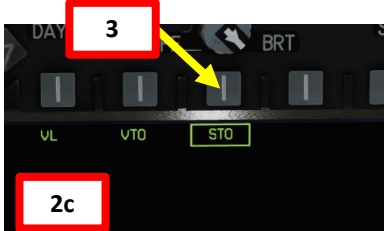

2c

	WET	DRY
NRAS	106	116
NOZ	60	60
GROL	1040	1286
DTSO	1908	2199
ASPD	***	***
SDST	***	***
ORTC	25	
ALTM	29.72	
FELV	64	
GWT	28752	
RUNK	07500 / 135DRY	
GWIND	155/005	

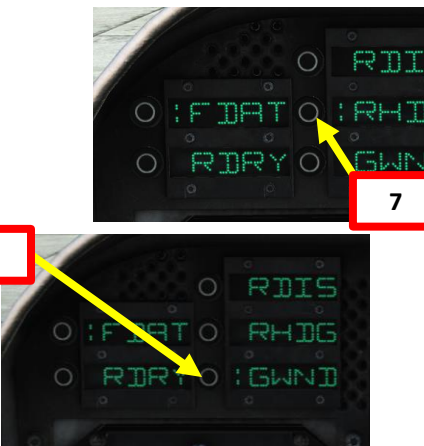

# 5 - SHORT TAKEOFF (STO)

11. On the VREST STO page, press the OSB next to "ABRT" to calculate your Abort Criteria.
12. A number of takeoff parameters are then calculated for Wet Thrust (with Water Injection Cooling) and Dry Thrust (without Water Injection Cooling).
13. A NRAS (Nozzle Rotation Airspeed) is the speed at which we will rotate the nozzle. We will use 106 kts.
14. A NOZ (Nozzle Angle) setting is the nozzle angle we will use to transition from forward acceleration to a positive rate of climb.
15. Your ASPD (Abort Speed) is calculated for Wet Thrust (with Water Injection Cooling) and Dry Thrust (without Water Injection Cooling). Below this speed you can still abort your takeoff, but above this speed your are committed to takeoff.
16. Your SDST (Stopping Distance) is calculated as well in feet. This is not particularly useful for ground airports with no distance markings, but this value is useful for ship takeoffs on the LHA-1 Tarawa since you will have a much shorter distance available for takeoff and there are distance markings on the ship.

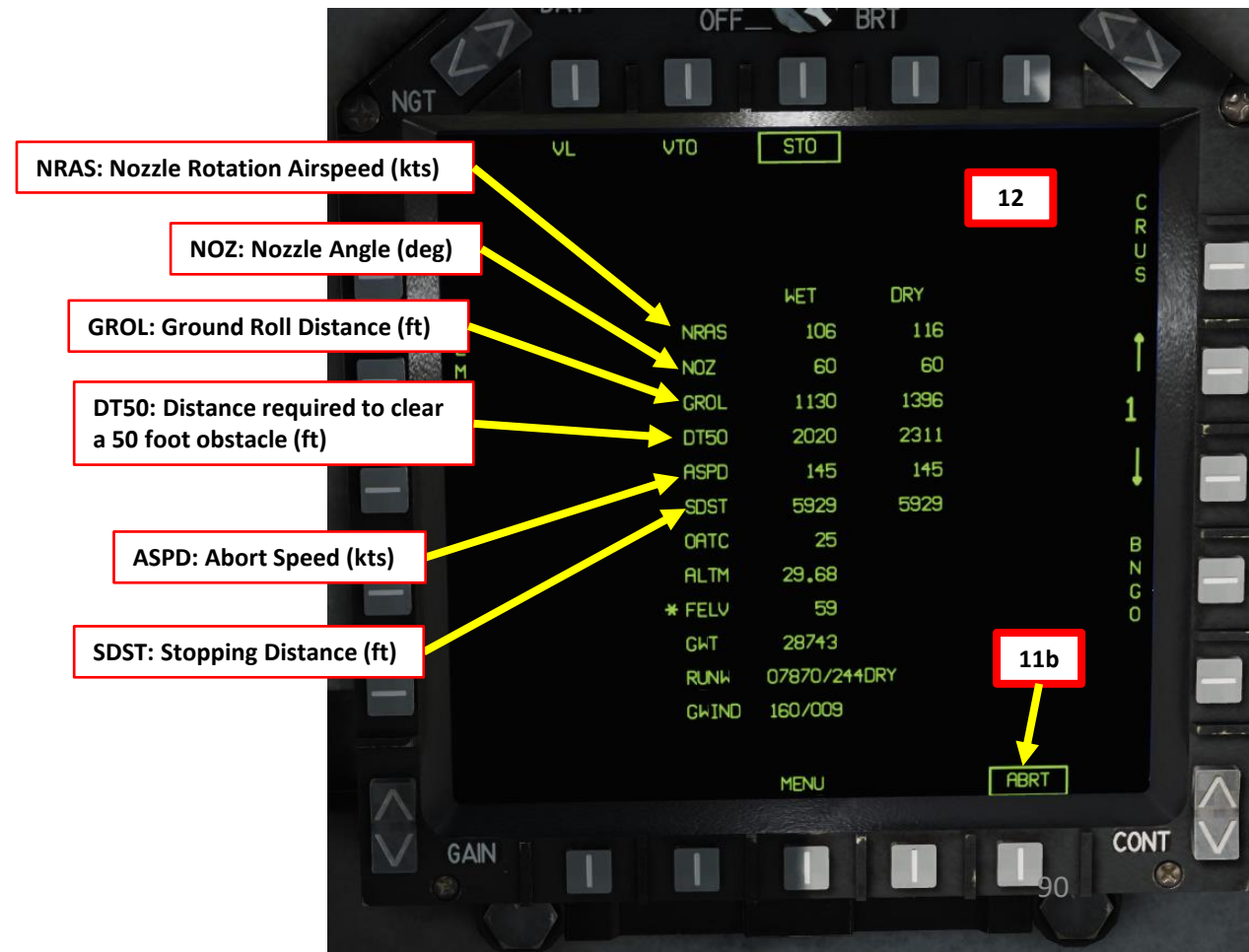
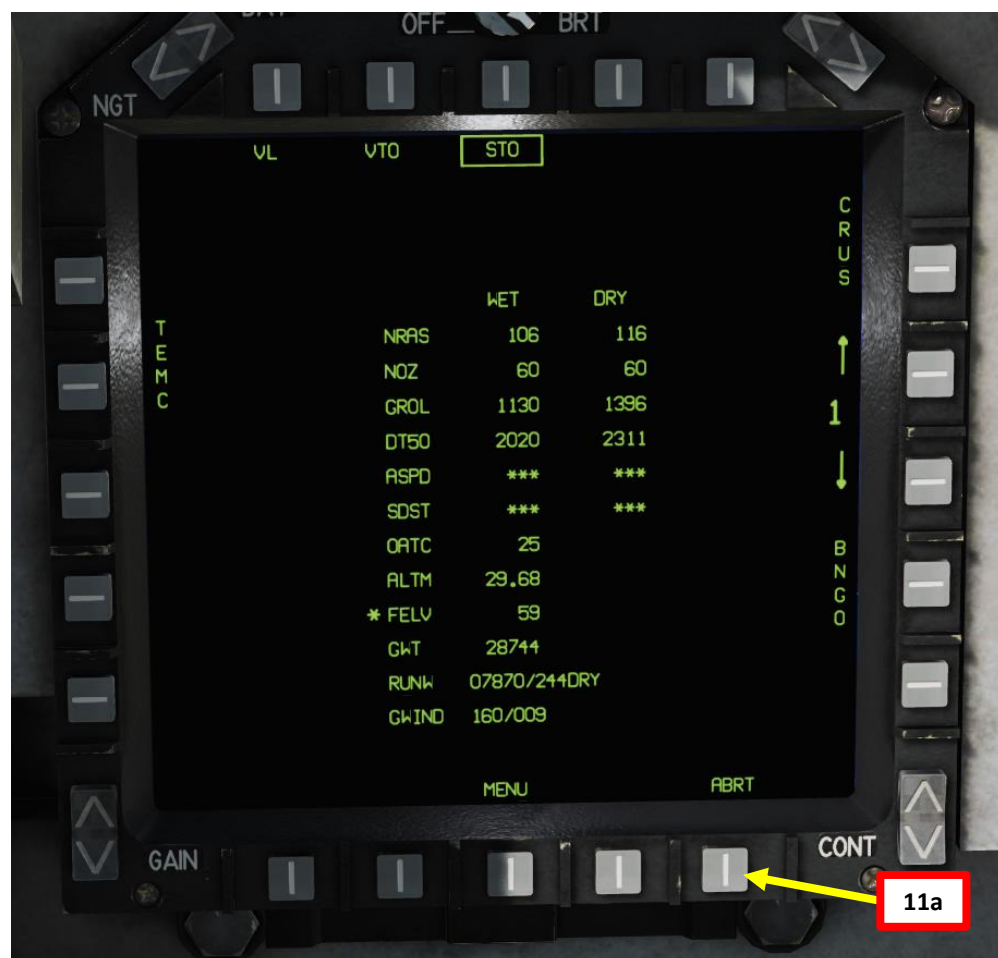

# 5 - SHORT TAKEOFF (STO)

17. Press the V/STOL Master Mode button to colonize the ODU (Option Display Unit) with V/STOL (Vertical/Short Takeoff & Landing) options.
18. Select ODU button next to NRAS (":" means selected), then enter "106" on the UFC scratchpad, then press "ENT". Nozzle Rotation Airspeed (NRAS) setting will box the HUD airspeed indicator when the aircraft has reached the entered NRAS speed, at which we shall rotate the nozzle from 10 deg to the required NOZ nozzle angle calculated on VREST page (60 deg)
19. Select ODU button next to PC, or "Pitch Caret" (":" means selected), then verify that "14 deg" is the value displayed on the UFC scratchpad, then press "ENT". This means the Pitch Carets are placed 6 deg above the horizon, where we will seek to place the Depressed Attitude Indicator / Witch's Hat for an accelerating transition into a positive rate of climb.

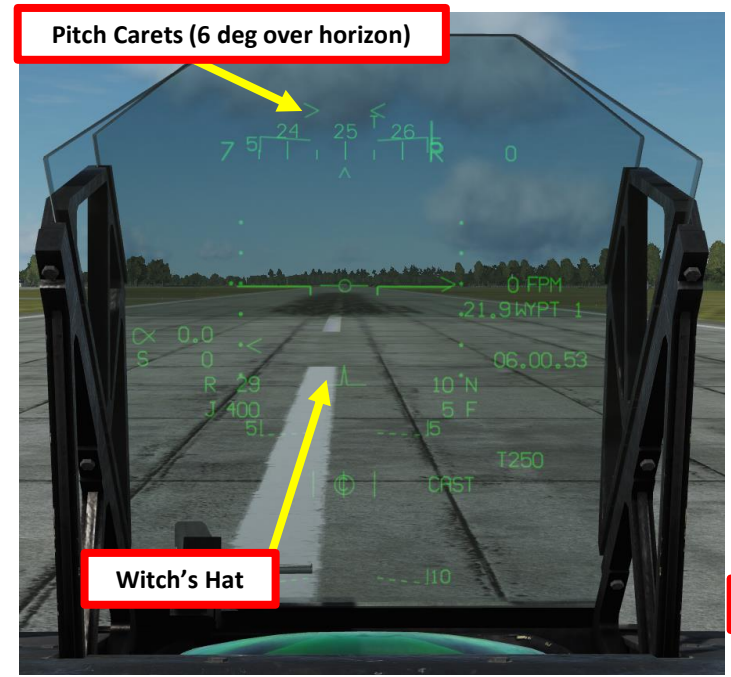

# 5 - SHORT TAKEOFF (STO)

- 20. Set STO STOP stopper at 60 deg
- 21. Set Nozzle Position Lever – 10 deg
- 22. Flaps Lever – AUTO (or STOL if desired)
- 23. Set H2O Water Injection Switch – TAKEOFF (UP) (only if required in case of heavy payload)
- 24. Set Stabilator Trim to Takeoff Trim (2 deg nose down)
- 25. Check that Anti-Skid Switch is ON
- 26. Hold Brakes
- 27. Throttle up (make sure the limit icon does not go to FULL) and press the NWS HOTAS button to line up the aircraft with the center of the runway if need be
- 28. You will begin to have aerodynamic control of the rudder at 50-60 kts

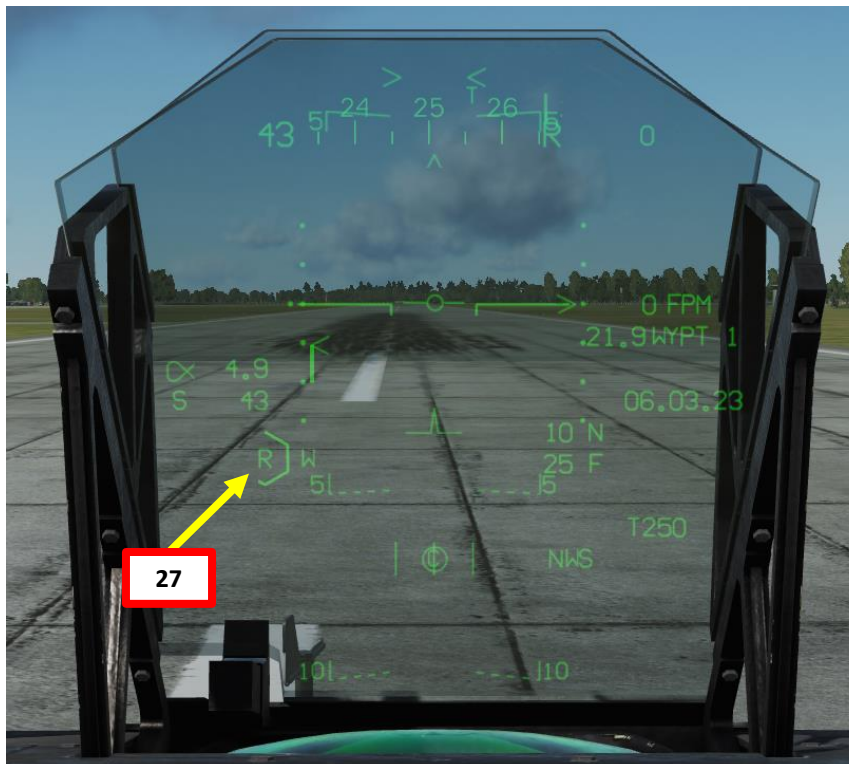
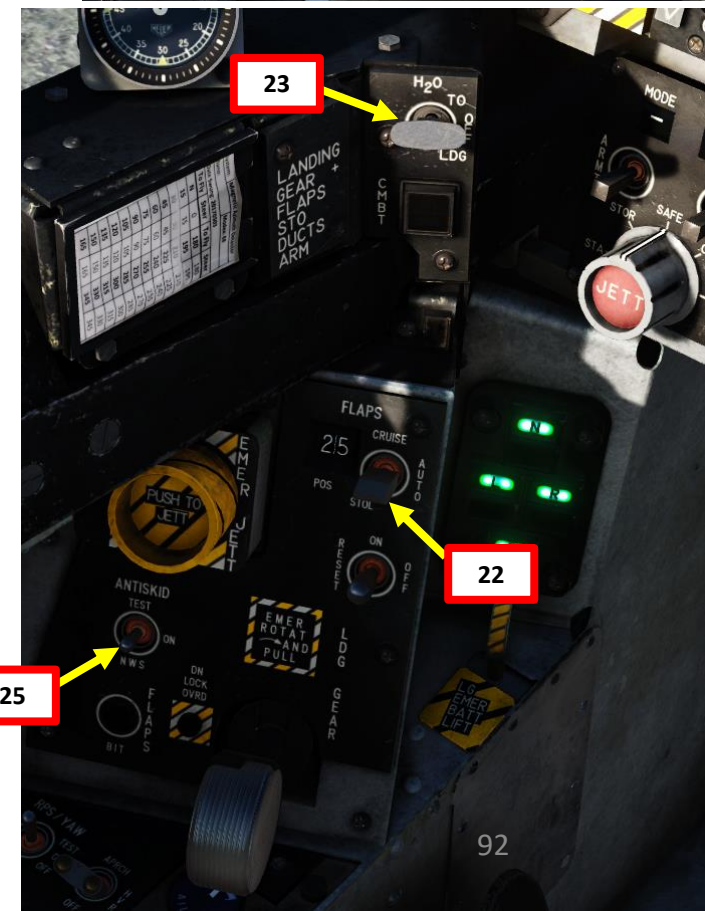
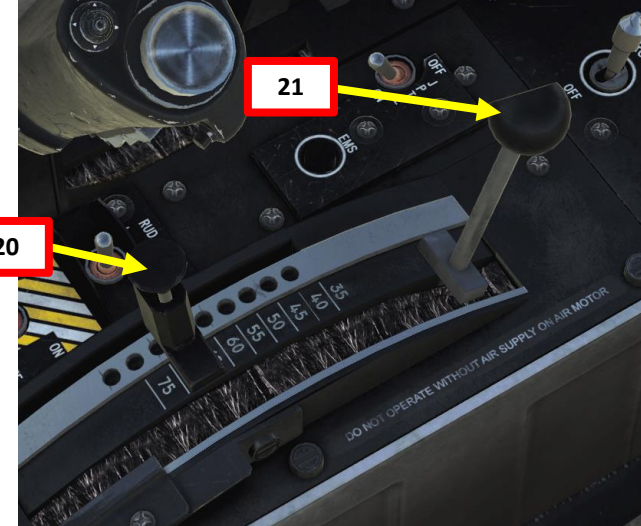
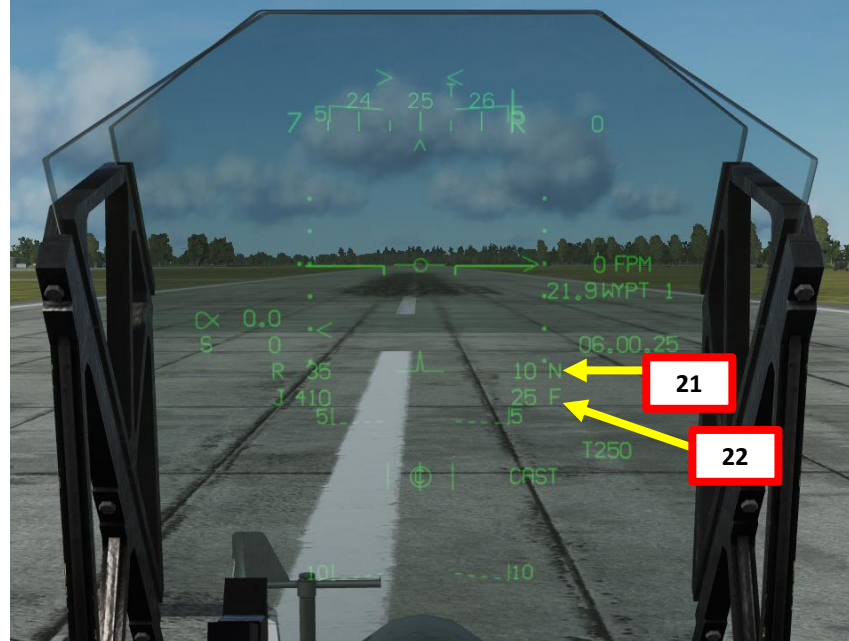

# 5 - SHORT TAKEOFF (STO)

- 29. When reaching the Nozzle Rotation Speed (106 kts in our case), set Nozzle Position Lever AFT to the STO position set previously), which is 60 deg in our case. The STO STOP lever will act as a mechanical stopper to your Nozzle lever.
- 30. You should start ascending vertically
- 31. During liftoff, ensure wings remain level and center the sideslip vane to takeoff into the wind
- 32. Set aircraft attitude: line up Witch Hat with the Pitch Carets (currently set to a fixed value of 14 deg, or 6 deg elevation above horizon line).
- 33. After liftoff, set landing gear lever UP
- 34. Gradually set Nozzles to 0 deg (maintain nozzles at 25 deg while flaps are still in STOL at 25 deg)
- 35. Set Water H2O Water Injection Switch – OFF (MIDDLE)

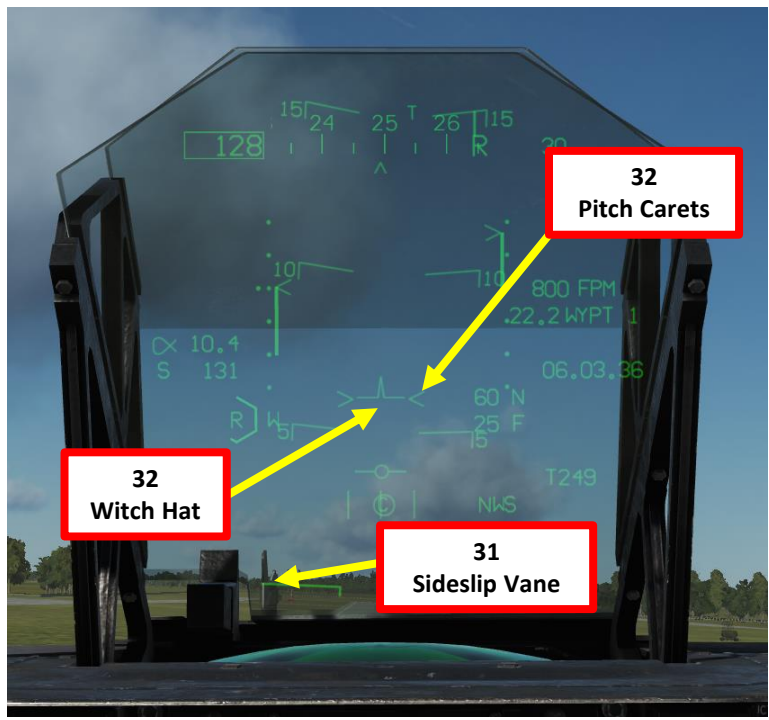
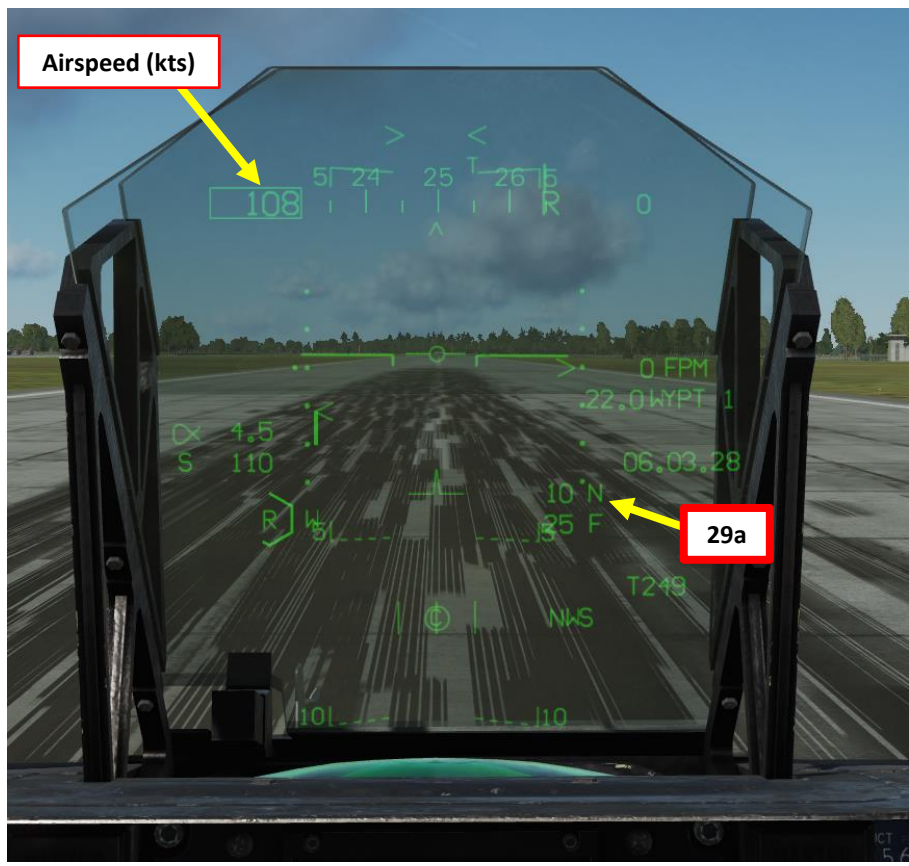

5 - SHORT TAKEOFF (STO)

CHECK THE ENGINES SECTION TO KNOW MORE ABOUT ENGINE OPERATION & LIMITS

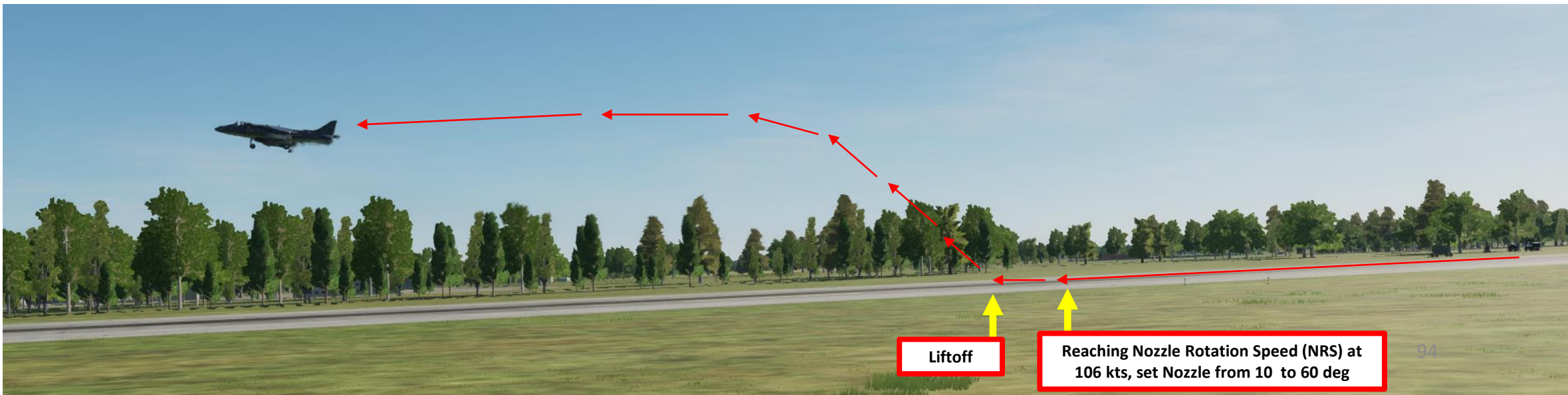

## 6 - VERTICAL TAKEOFF (VTO)

Note: Check beforehand that your aircraft weight is **below 20500 lbs** or you may never leave the ground. Vertical takeoffs are very restrictive in terms of what payload you can carry.

1. Make sure the V/STOL Master Mode button is active and the VREST page is accessible from the MPCD main menu, then select VREST (Vertical/Short Takeoff & Landing, Range, Endurance, Speed & Time) page.
2. Press OSB next to "VTO" to select "Vertical Takeoff" sub-page.
3. Make sure the GWT (Gross Weight) computed is below 20500 lbs.

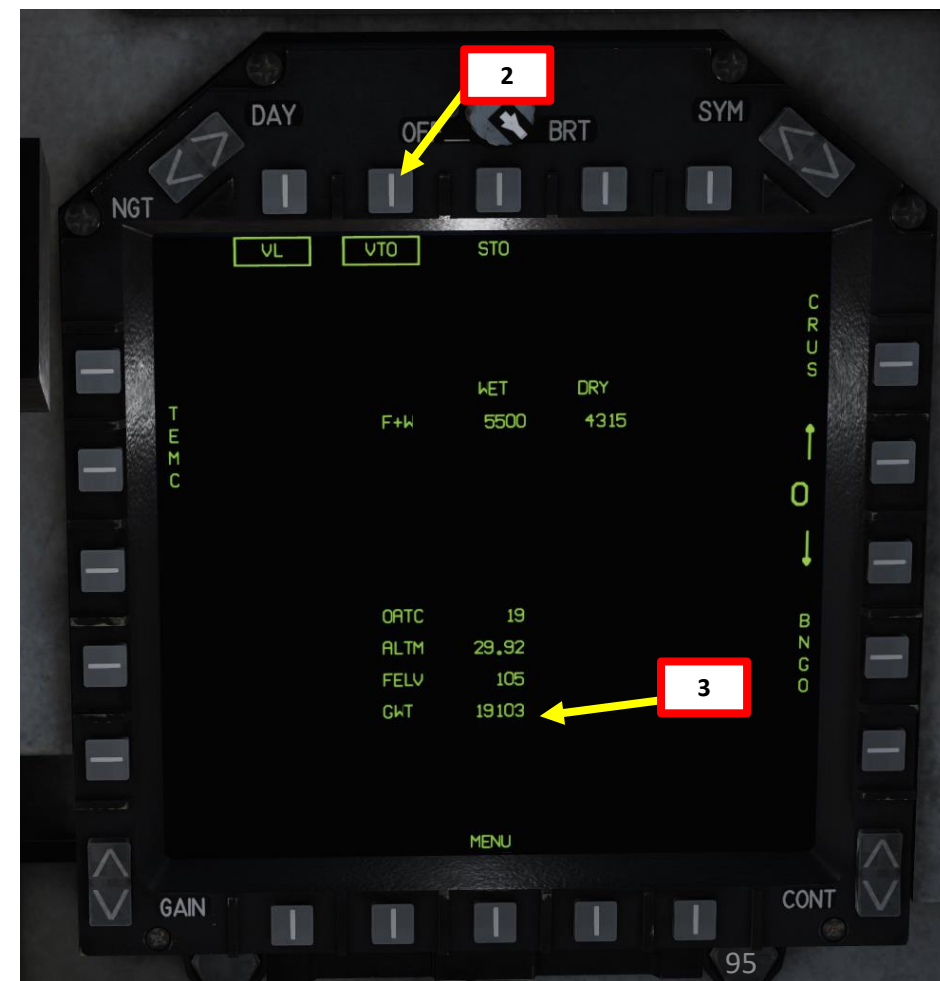
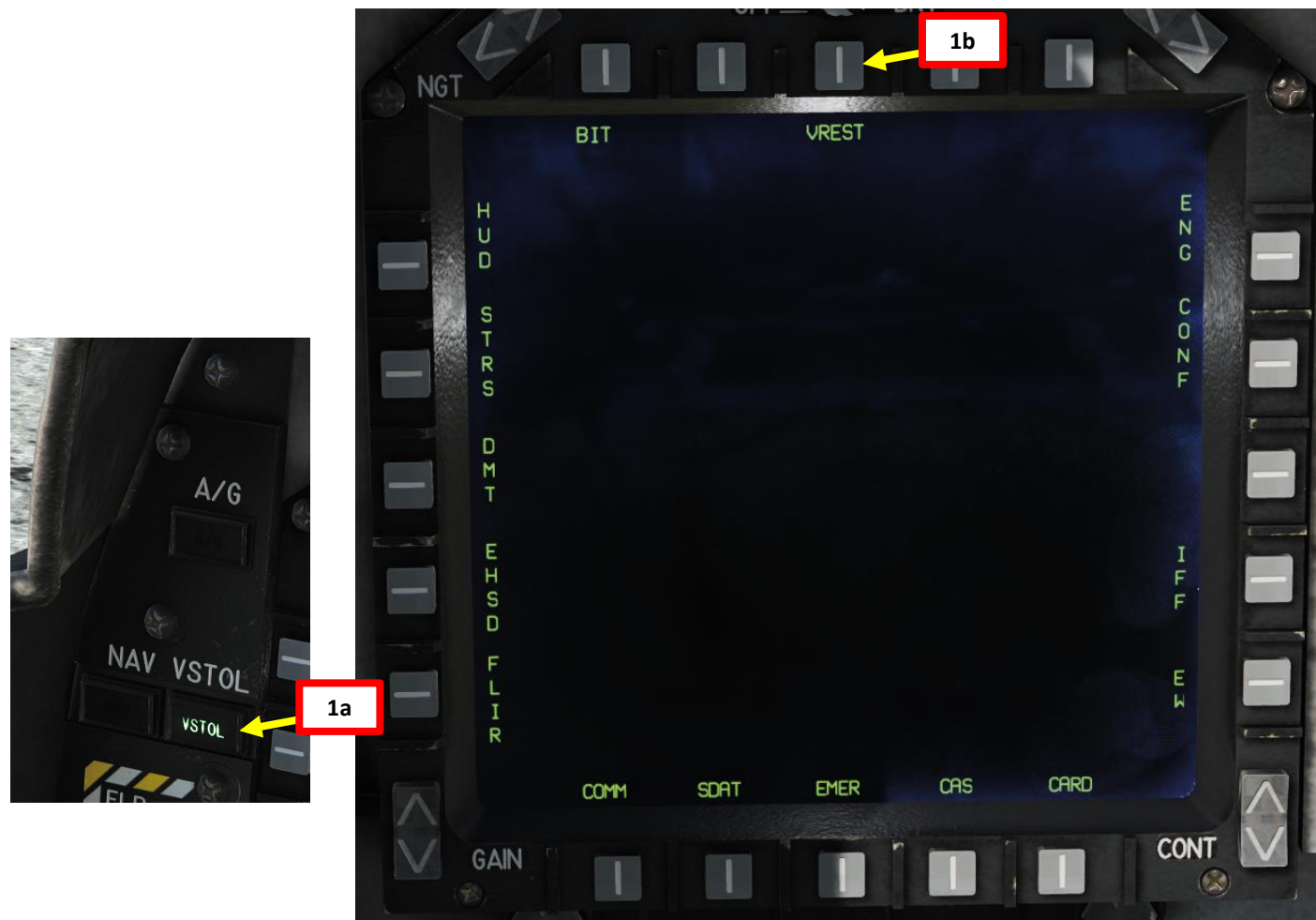

## 6 - VERTICAL TAKEOFF (VTO)

4. Set STO STOP stopper fully AFT (CLEAR)
5. Set Nozzle Position Lever – 82 deg
6. Flaps Lever – STOL (61 deg)
7. Set H2O Water Injection Switch – TAKEOFF (UP) (only if required in case of heavy payload)
8. Set Stabilator Trim to Takeoff Trim (2 deg nose down)
9. Check that Anti-Skid Switch is ON
10. Hold Brakes

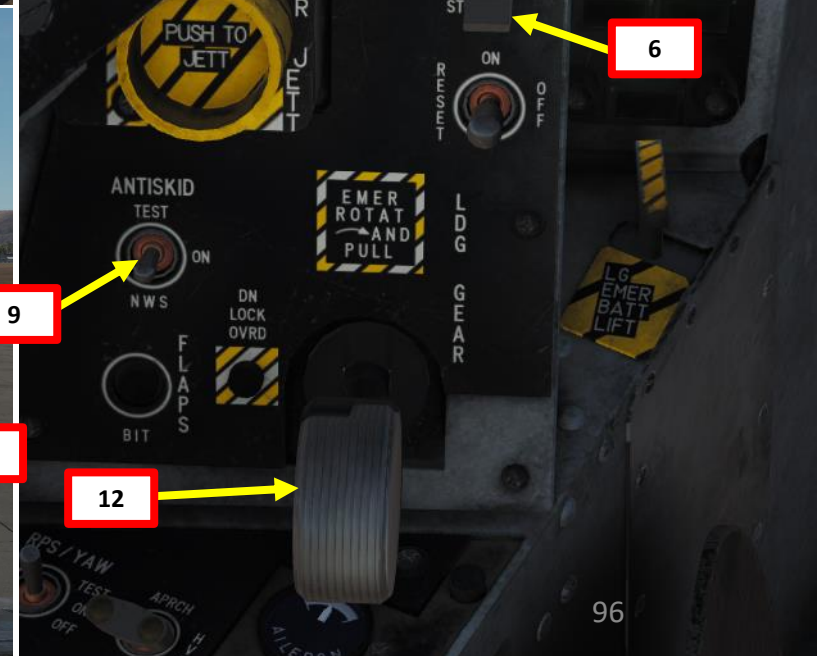
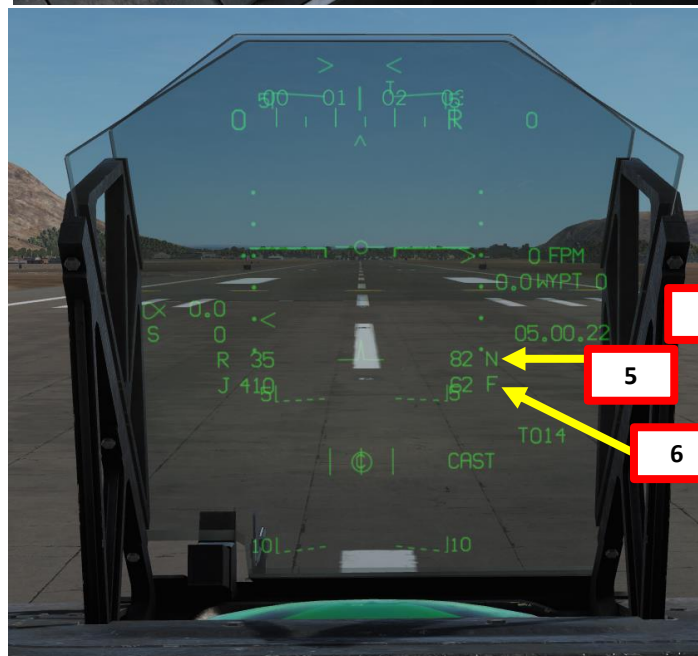
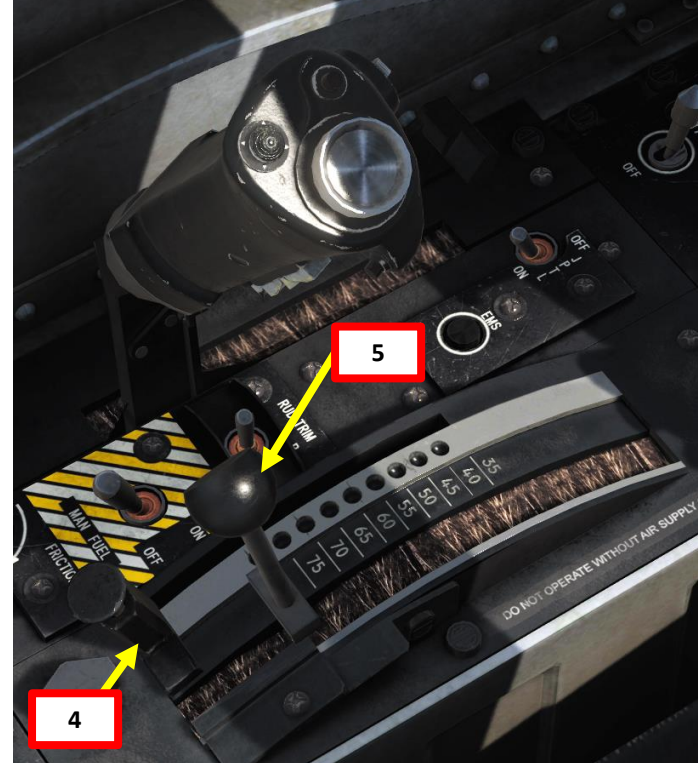

## 6 - VERTICAL TAKEOFF (VTO)

11. Throttle up gradually until liftoff in one smooth motion (make sure the limit icon does not go to FULL)
12. During liftoff, ensure wings remain level and center the sideslip vane to takeoff into the wind. Adjust attitude to prevent fore/aft drift. Refrain from pulling on the stick unless forward speed is developing, as hot RCS (Reaction Control System, which controls engine thrust to maintain a specific aircraft attitude) gas from the nose will raise temperatures and reduce engine performance.
13. When clear of ground effect (20-25 ft), gradually reduce power to establish hover.
14. When passing 50 ft and clear of obstacles, set your accelerating attitude by placing the Witch's Hat at the Pitch Carets (14 deg) and begin nozzling out towards 0 deg simultaneously.
15. You will center the sideslip vane and V/STOL sideslip ball in the HUD an using rudder pedals prior to reaching 30 kts, and remain wings level while gradually reducing nozzle angle even further.

CHECK THE ENGINES SECTION  
TO KNOW MORE ABOUT  
ENGINE OPERATION & LIMITS

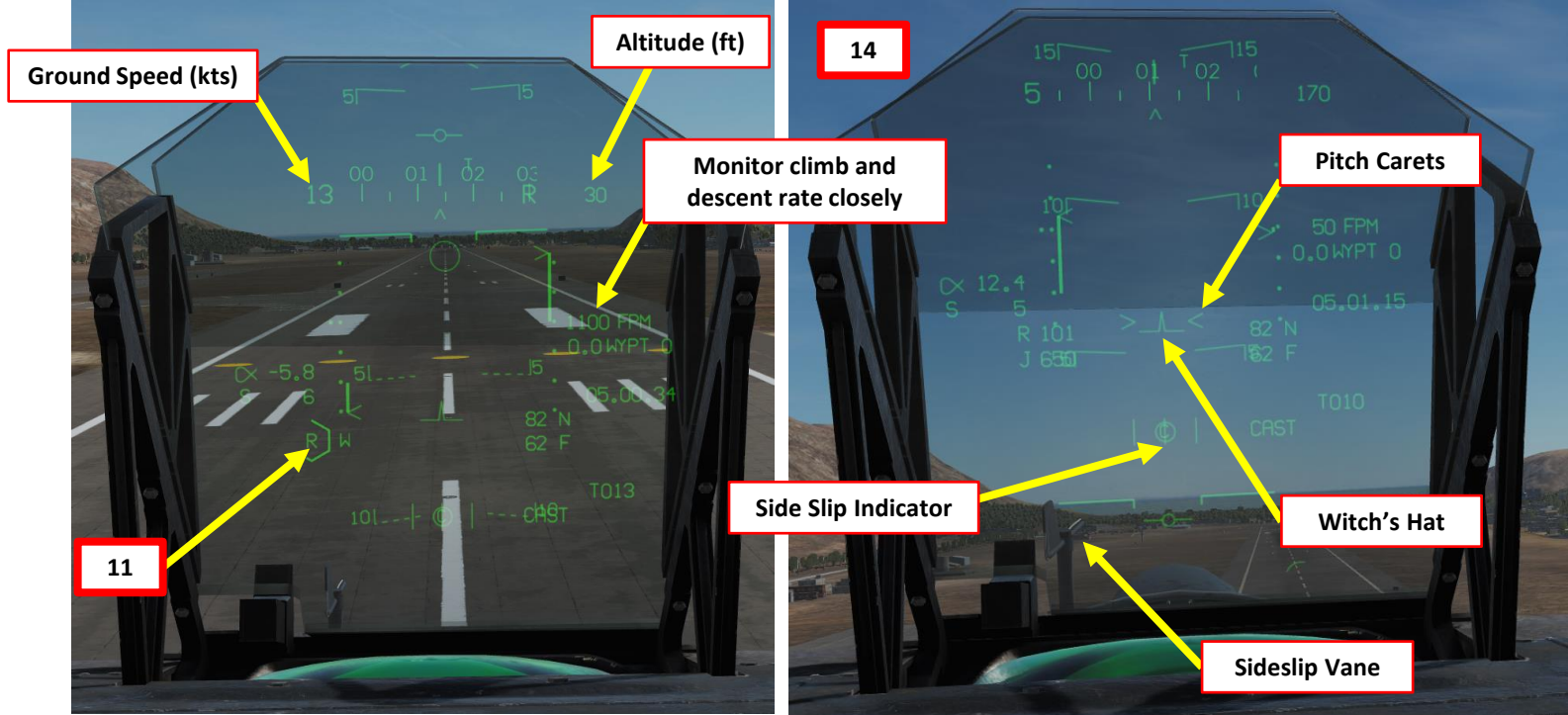

## 6 - VERTICAL TAKEOFF (VTO)

16. Once established in wingborne flight, reduce power and complete the nozzle out to fully AFT (0 deg). Maintain climbing flight and ensure velocity vector does not descend below horizon bars in the HUD.
17. After liftoff (wingborne flight, airspeed greater than 120 kts), set landing gear lever UP
18. Set Flaps switch to AUTO
19. Set Water H2O Water Injection Switch – OFF (MIDDLE)

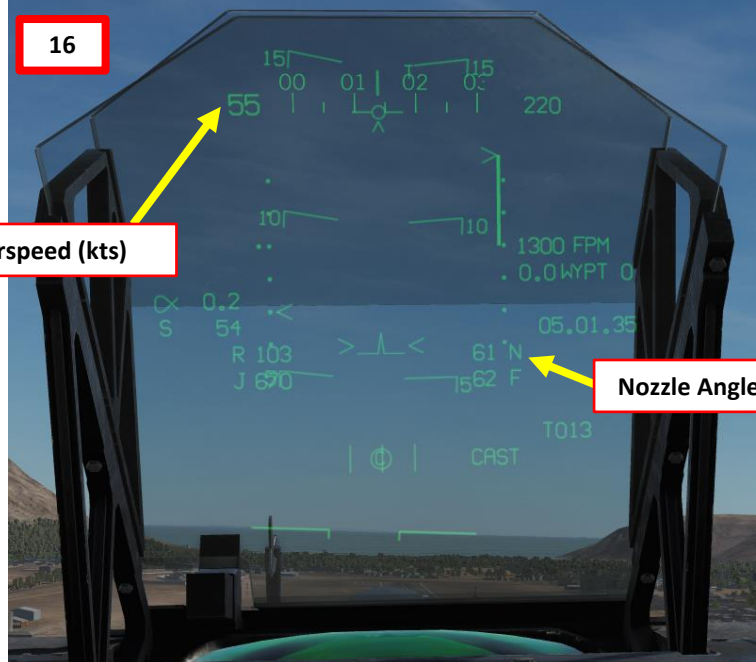

Airspeed (kts)

Nozzle Angle (deg)

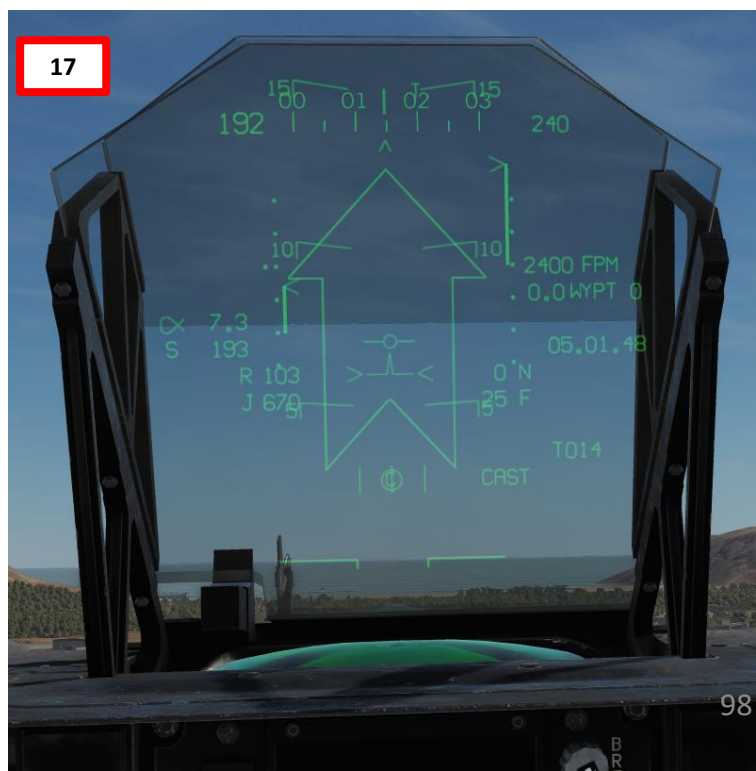

17

# 7 - ROLLING VERTICAL TAKEOFF (RVTO)

**Note:** You need at least 100 ft of runway to perform a RVTO. Similar weight restrictions to the Vertical Takeoff apply. Keep in mind that vertical takeoffs are restrictive in terms of what payload you can carry. Typically, RVTOs in the Harrier are **not** performed on carriers.

1. Set STO STOP stopper at 70 deg
2. Set Nozzle Position Lever – 30 deg
3. Flaps Lever – STOL (flaps will go in an intermediate position since nozzle angle is at 30 deg)
4. Set H2O Water Injection Switch – TAKEOFF (UP) (only if required in case of heavy payload)
5. Set Stabilator Trim to Takeoff Trim (2 deg nose down)
6. Check that Anti-Skid Switch is ON
7. Hold Brakes

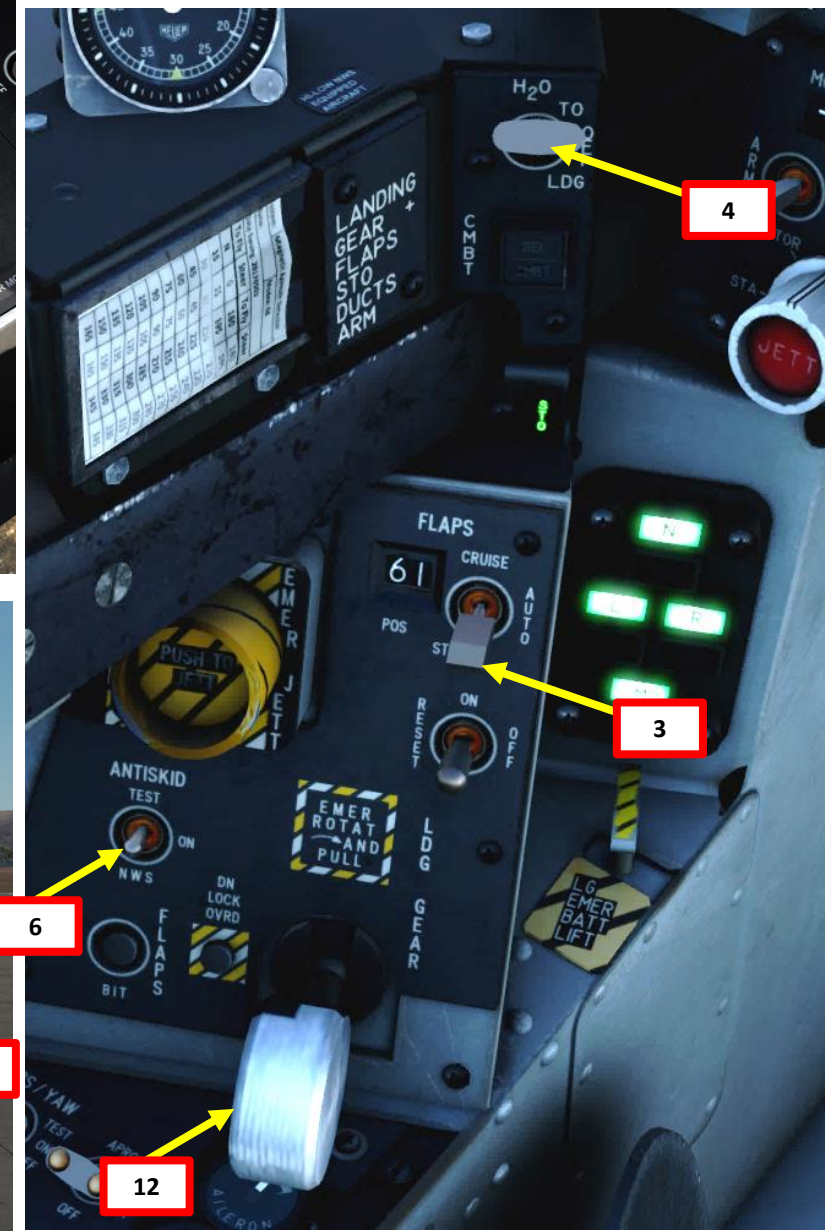
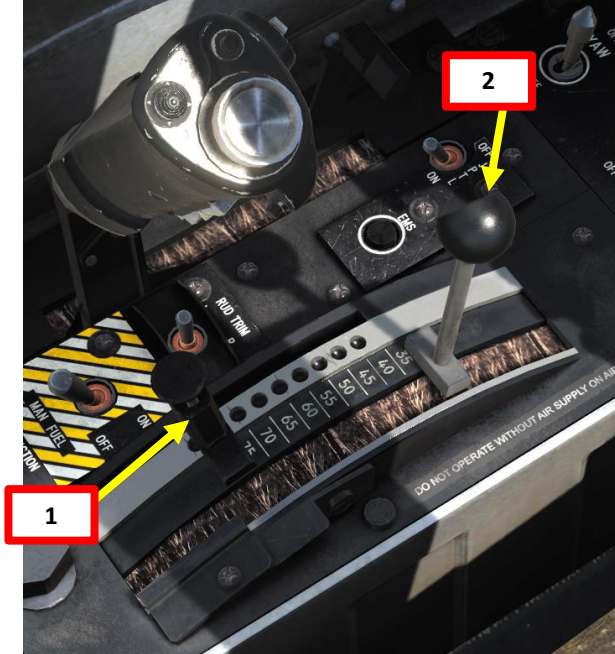

## 7 - ROLLING VERTICAL TAKEOFF (RVTO)

8. Throttle up, release brakes and press the NWS HOTAS button to line up the aircraft with the center of the runway if need be
9. As RPM increases to 110 % RPM, set Nozzle Position Lever AFT to the STO position set previously), which is 70 deg in our case. The STO STOP lever will act as a mechanical stopper to your Nozzle lever.
10. You should then start ascending vertically.
11. During liftoff, ensure wings remain level and center the sideslip vane to takeoff into the wind
12. Set aircraft attitude: line up Witch Hat with the Pitch Carets (currently set to a fixed value of 14 deg, or 6 deg elevation above horizon line).
13. Once established in wingborne flight, reduce power and complete the nozzle out to fully AFT (0 deg). Maintain climbing flight and ensure velocity vector does not descend below horizon bars in the HUD.
14. After liftoff (wingborne flight, airspeed greater than 120 kts), set landing gear lever UP
15. Set Flaps switch to AUTO
16. Set Water H2O Water Injection Switch – OFF (MIDDLE)

CHECK THE ENGINES SECTION TO KNOW MORE ABOUT ENGINE OPERATION & LIMITS

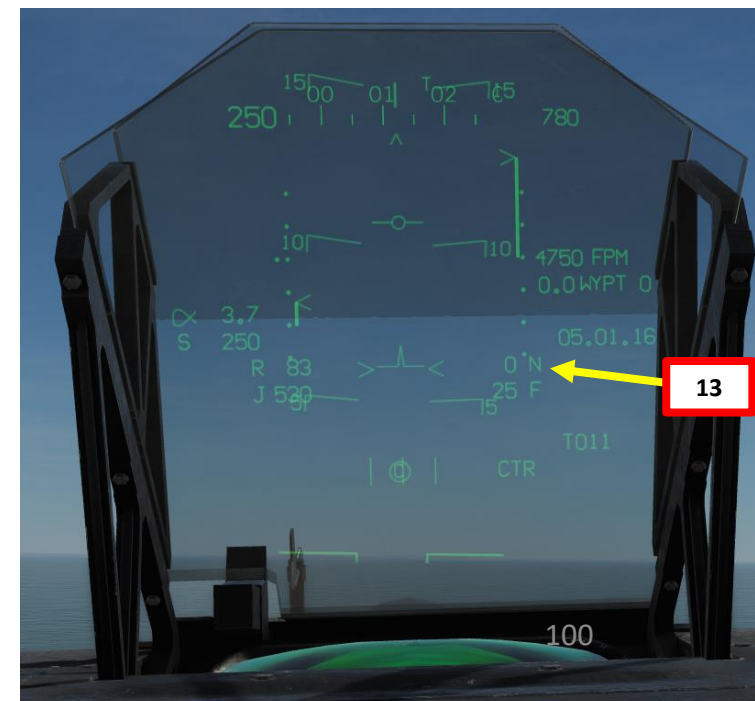
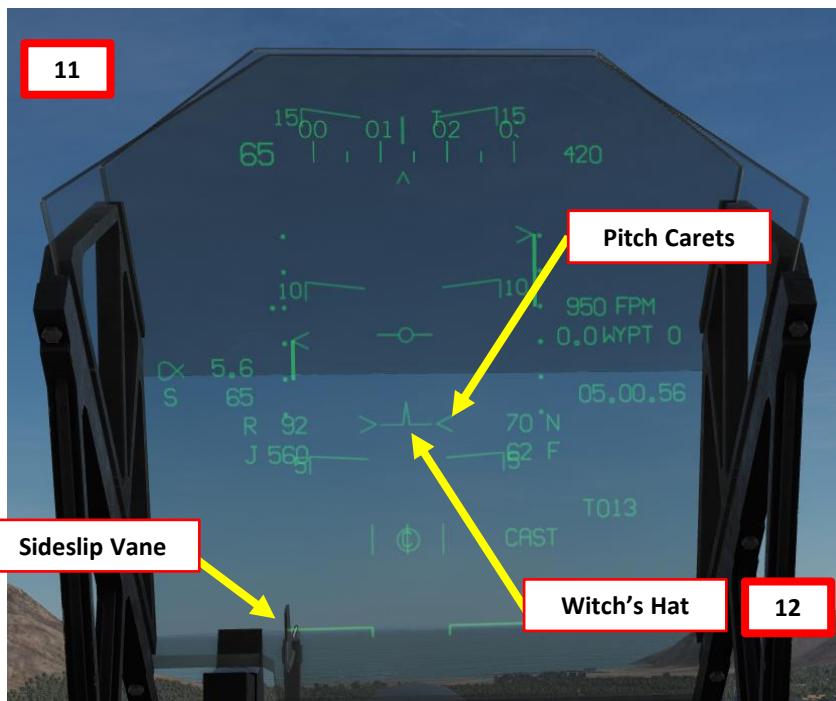
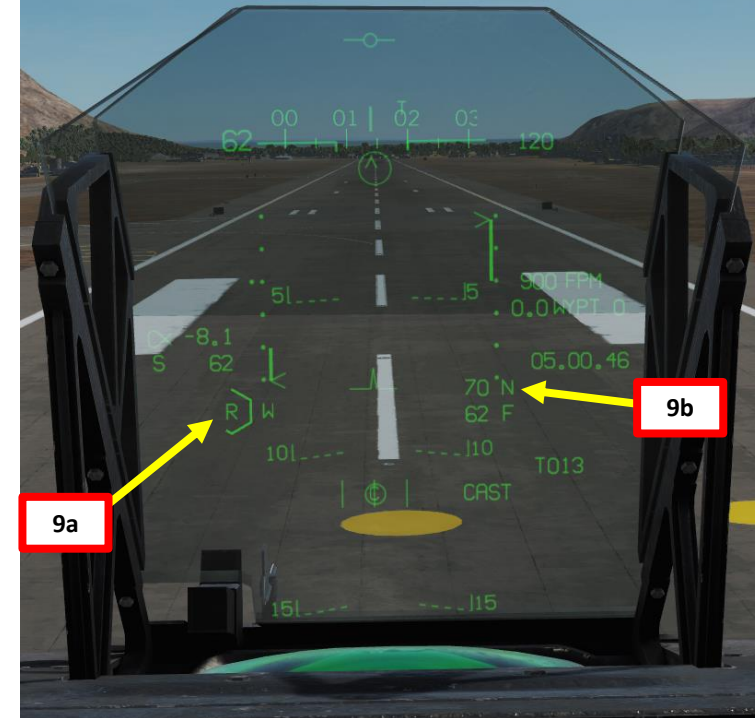

7 - ROLLING VERTICAL TAKEOFF  
(RVTO)

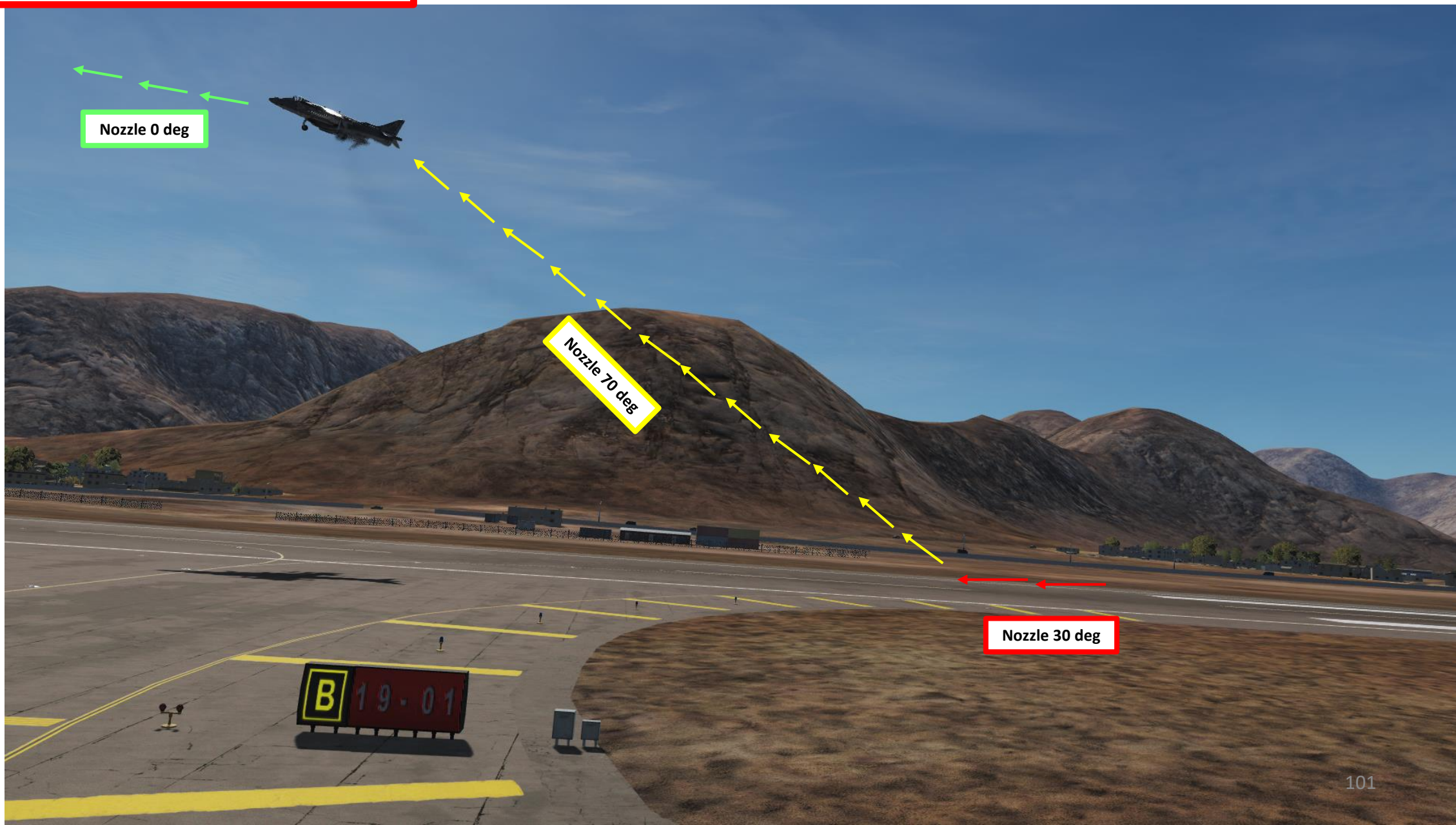

## 8 - SHIP TAKEOFF

**Note:** taking off on a ship like the amphibious assault ship LHA-1 Tarawa is slightly different from the Short Takeoff we have seen before. The main difference is that instead of rotating the nozzles at a set NRAS (Nozzle Rotation Airspeed) calculated by the VREST page, we will rotate the nozzles once we reach the Nozzle Rotation Line, then transition into wingborne flight.



USS Tarawa  
(LHA-1)

## 8 - SHIP TAKEOFF

In real life, ship crews provide the pilot with a "Tote Board", which contains information about:

1. Takeoff Type (STO: Short Takeoff)
2. Calculated Takeoff Distance (ft)
3. Nose Trim for Takeoff (deg)
4. Nozzle Angle (set after crossing the Nozzle Rotation Line on the ship)
5. Takeoff Thrust Setting (WET uses Water Injection, DRY does not use Water Injection)
6. Maximum Allowable Takeoff Weight (lbs)

You will want to place your Harrier to have enough distance for takeoff by checking the Distance Markings on the ship's deck.

An Aviation Boatswain's Mate (Handling) uses a Tote Board to communicate with the pilot of a Harrier prior to launch from the flight deck (U.S. Navy photo by Mass Communication Specialist 3rd Class Michael Molina/Released)



700 ft Takeoff Distance Marking



TOTE BOARD	
1.	STO
2.	460
3.	0 deg (neutral)
4.	60 deg
5.	DRY
6.	25250

# 8 - SHIP TAKEOFF

Since no "Tote Board" is provided in DCS, we will use a plausible one taken from Baltic Dragon's (Amazing) Training Missions.

1. Place the aircraft behind a Distance Marking that leaves you sufficient distance for takeoff (at the very least 460 ft).
2. Make sure the V/STOL Master Mode button is active and the VREST page is accessible from the MPCD main menu, then select VREST (Vertical/Short Takeoff & Landing, Range, Endurance, Speed & Time) page.
3. Press OSB next to "STO" to select "Short Takeoff" sub-page.
4. Verify that GWT (Gross Weight) of aircraft is below 25250 lbs.

TOTE BOARD	
1.	STO
2.	460
3.	0 deg (neutral)
4.	60 deg
5.	DRY
6.	25250

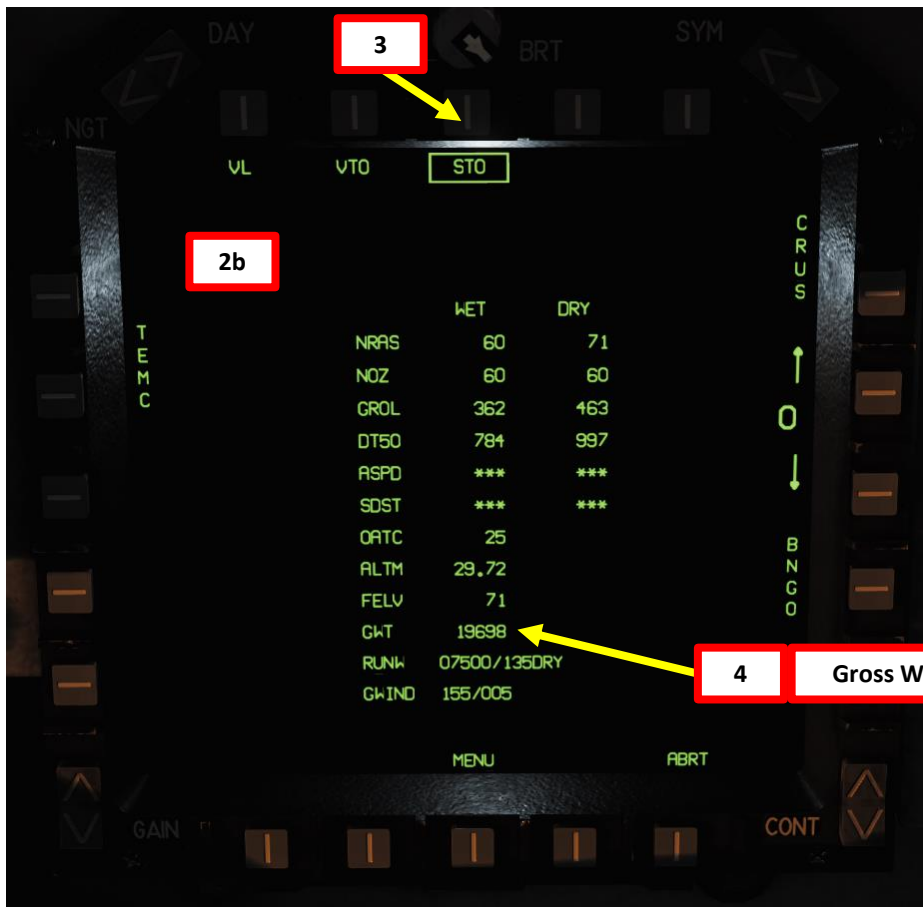

# 8 - SHIP TAKEOFF

5. Since we will not use a NRAS (Nozzle Rotation Airspeed) as a reference to rotate our nozzles, we will not need to calculate our Abort Criteria.
6. Set STO STOP stopper at 60 deg
7. Set Nozzle Position Lever – 10 deg
8. Flaps Lever –STOL
9. Set H2O Water Injection Switch – As Required. We will leave Water Injection to OFF, but take note that you should set it to TAKEOFF (UP) in case of heavy payload.
10. Set Stabilator Trim to Takeoff Trim (0 deg, neutral)
11. Check that Anti-Skid Switch is OFF (NWS/DOWN, very important!)

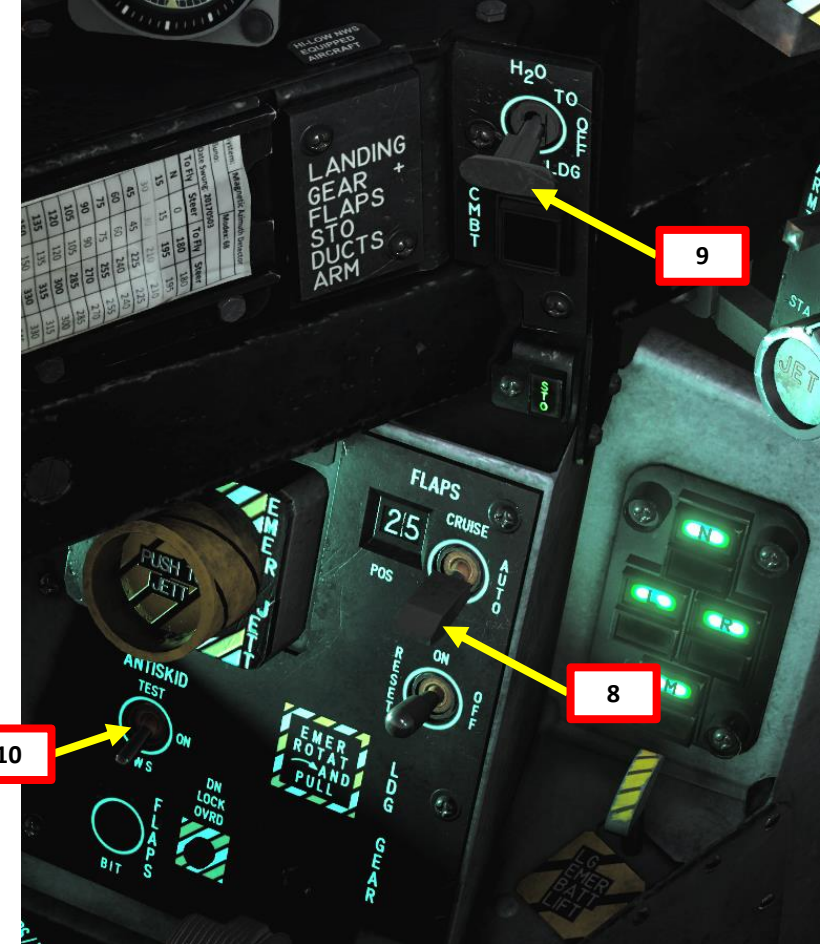
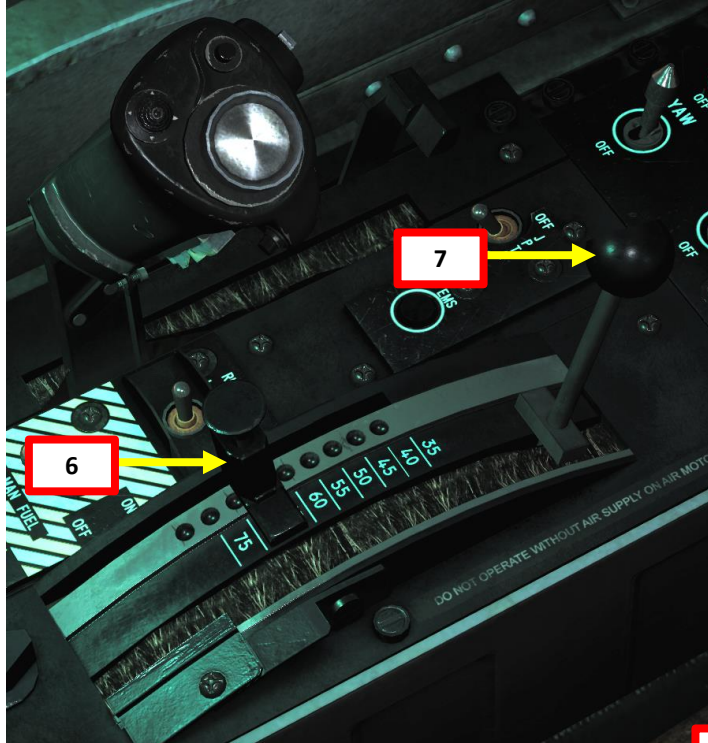

# 8 - SHIP TAKEOFF

12. Hold Brakes
13. Throttle up (make sure the limit icon does not go to FULL)
14. You will begin to have aerodynamic control of the rudder at 50-60 kts
15. Once you cross the Nozzle Rotation Line on the ship's deck, set Nozzle Position Lever AFT to the STO position set previously), which is 60 deg in our case. The STO STOP lever will act as a mechanical stopper to your Nozzle lever.
16. You should start ascending vertically
17. During liftoff, ensure wings remain level and center the sideslip vane to takeoff into the wind
18. Set aircraft attitude: line up Witch Hat with the Pitch Carets (currently set to a fixed value of 14 deg, or 6 deg elevation above horizon line).
19. After liftoff, set landing gear lever UP
20. Gradually set Nozzles to 25 deg
21. Above 120 kts, set Flaps to AUTO and set Nozzles to 0 deg
22. Set Water H2O Water Injection Switch – OFF (MIDDLE)

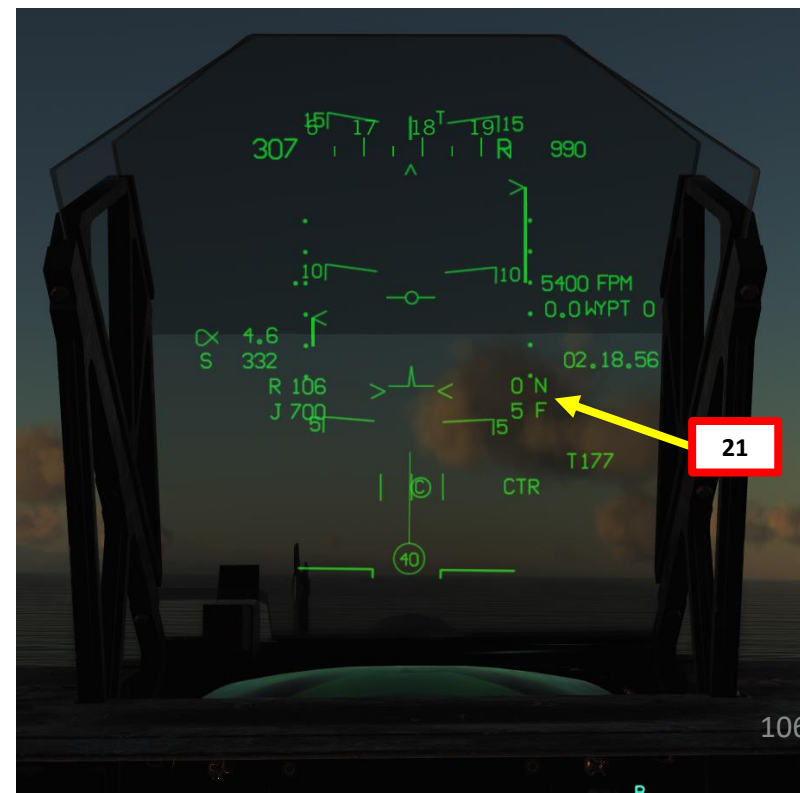
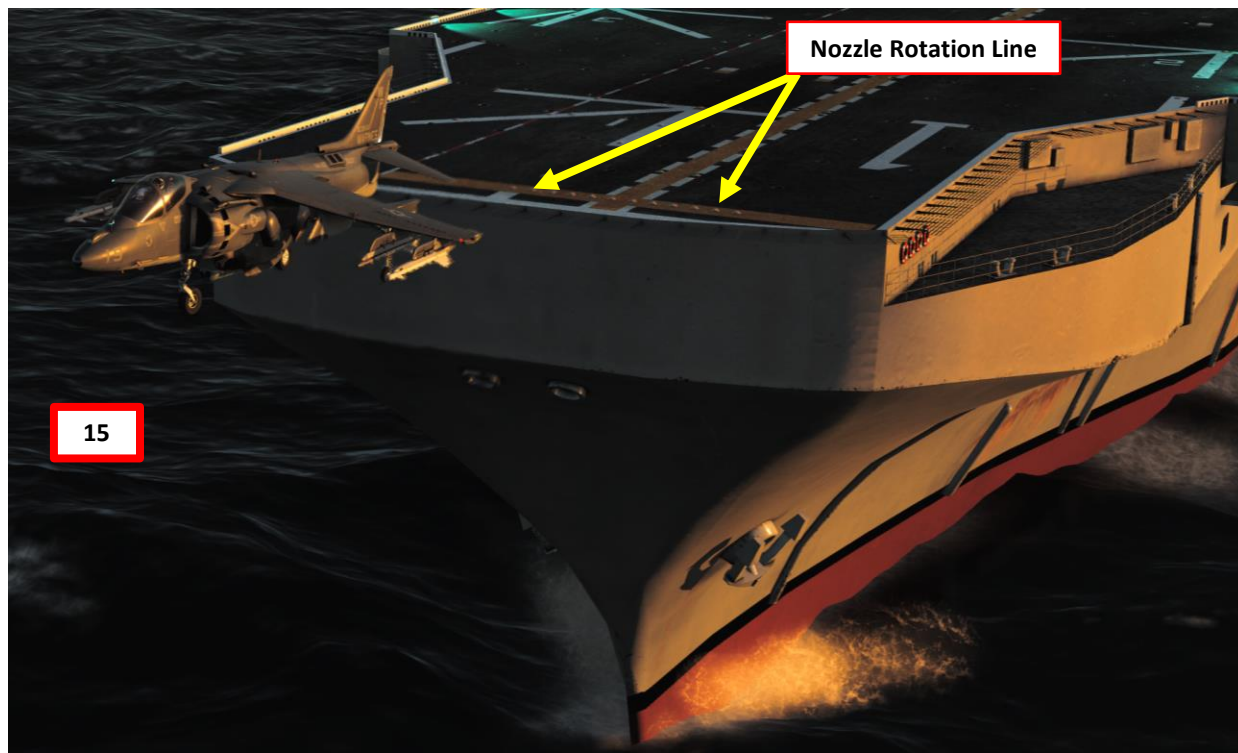
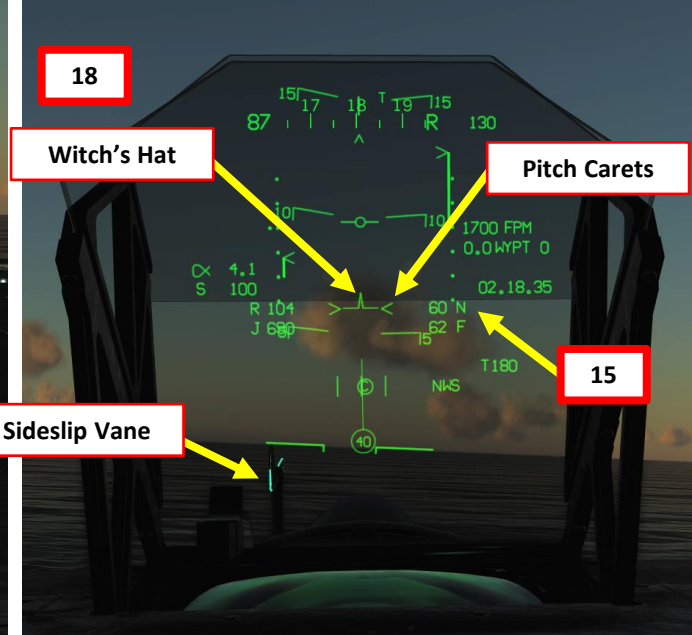

8 - SHIP TAKEOFF

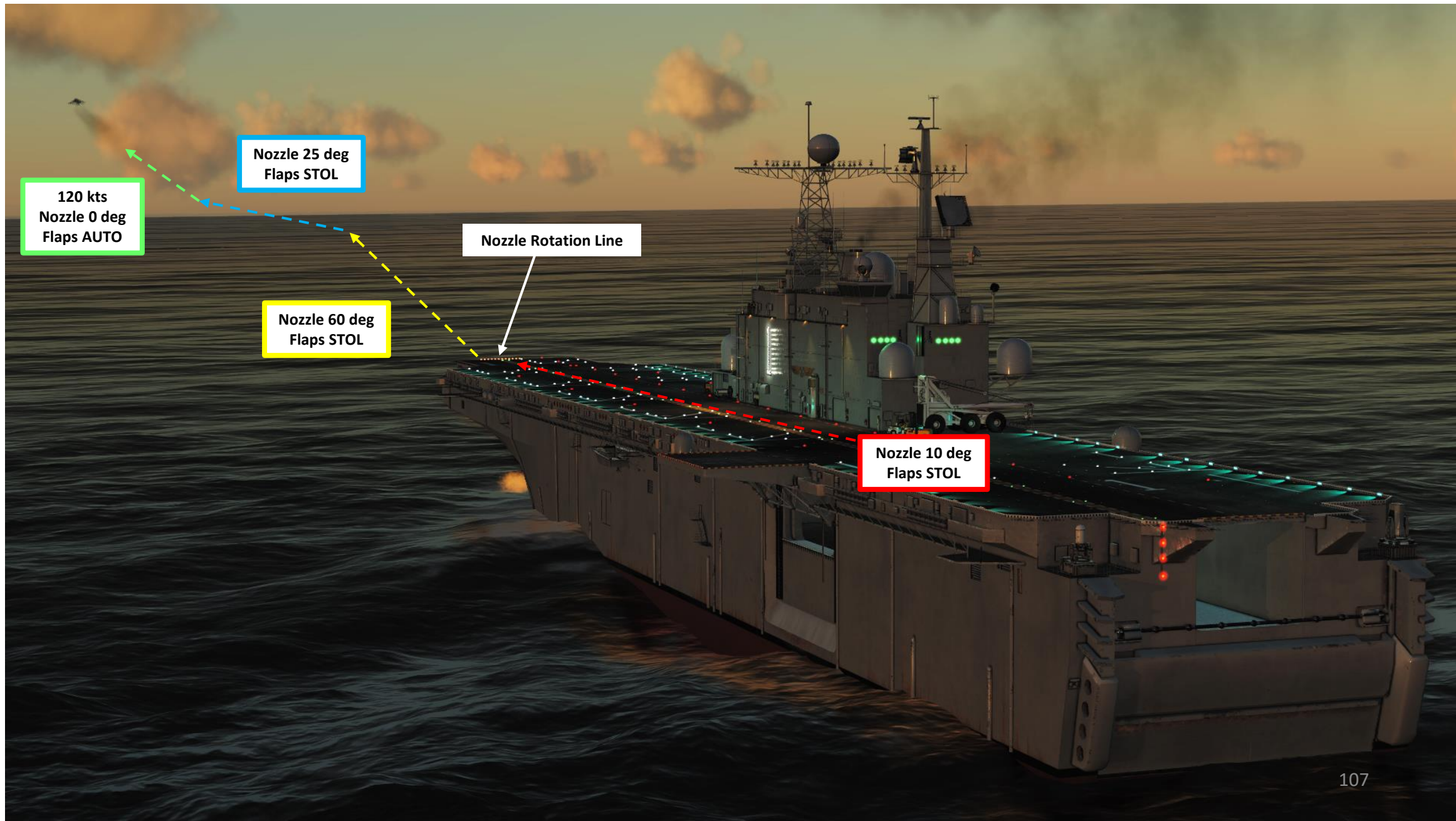

120 kts  
Nozzle 0 deg  
Flaps AUTO

Nozzle 25 deg  
Flaps STOL

Nozzle 60 deg  
Flaps STOL

Nozzle Rotation Line

Nozzle 10 deg  
Flaps STOL

## LANDING TUTORIAL STRUCTURE

1. Weight Calculations
2. Stores & Fuel Jettison
3. Landing Types
4. Conventional Landing (CL)
5. Slow Landing – Variable Nozzle (VNSL)
6. Slow Landing – Fixed Nozzle (FNSL)
7. Rolling Vertical Landing (RVL)
8. Vertical Landing (VL)
9. Case I Recovery (Ship Landing)

# 1 - WEIGHT CALCULATIONS

Vertical landing on a ship needs some preparation. You cannot land vertically in any configuration: you need to make sure that you are light enough to be able to hover without smashing yourself against the ship's deck.

To land successfully on a ship, your **weight must not exceed 20500 lbs.** This is why you'll have to calculate your weight on landing. Redkite prepared some nice sheets to help you do it.

## Example of Weight Calculation:

You approach the Tarawa loaded with the following weight:

- Airframe (14000 lbs) + Water Tank (500 lbs)
- Gunpod (1313 lbs)
- 2 x Sidearms (2 x 200 lbs)
- 2 x Mavericks AGM-65F (2 x 485 lbs)
- A targeting pod (445 lbs)
- 4100 lbs fuel
- A pilot + Equipment (300 lbs approx.)

Your total weight is 22028 lbs, which is roughly 1500 lbs over the limit.

WEIGHT REFERENCE SHEET	
AIRFRAME: 14,000 lbs	WATER TANK: 500 lbs
BOMBS	WEIGHT
MK82/GBU-12/MK38	800 lbs
MK-84/GBU-10/MK31	2000 lbs
GBU-16	1243 lbs
MK-20 ROCKEYE	229 lbs
MK-83	9985 lbs
SUU-26 x 8 LUU-2	286 lbs
MISSILES	WEIGHT
AGM-65F MAVERICK	485 lbs
AGM-65G MAVERICK	674 lbs
SIDEARM	200 lbs
AIM-9 SIDEWINDER	118 lbs
ROCKETS	WEIGHT
7 x FFAR	261 lbs
4 x ZUNI MK71	970 lbs
19 x FFAR	630 lbs
7 x 2.7 in	262 lbs
EQUIPMENT	WEIGHT
2 x EXTERNAL TANKS (EMPTY)	416 lbs
TGP (TARGETING POD)	445 lbs
GAU-12 GUNPOD	1313 lbs
DECM POD	317 lbs



# 1 - WEIGHT CALCULATIONS

In order to see what you have loaded, you can consult the STORES page on your MPCD:

1. Click the OSB next to MENU
2. Click the OSB next to STRS (Stores)
3. You will have the STORES page open. As an example, you can see the Targeting Pod (TPOD), the Maverick (IRMV) and the Sidarm (SA) missiles on their respective pylons.

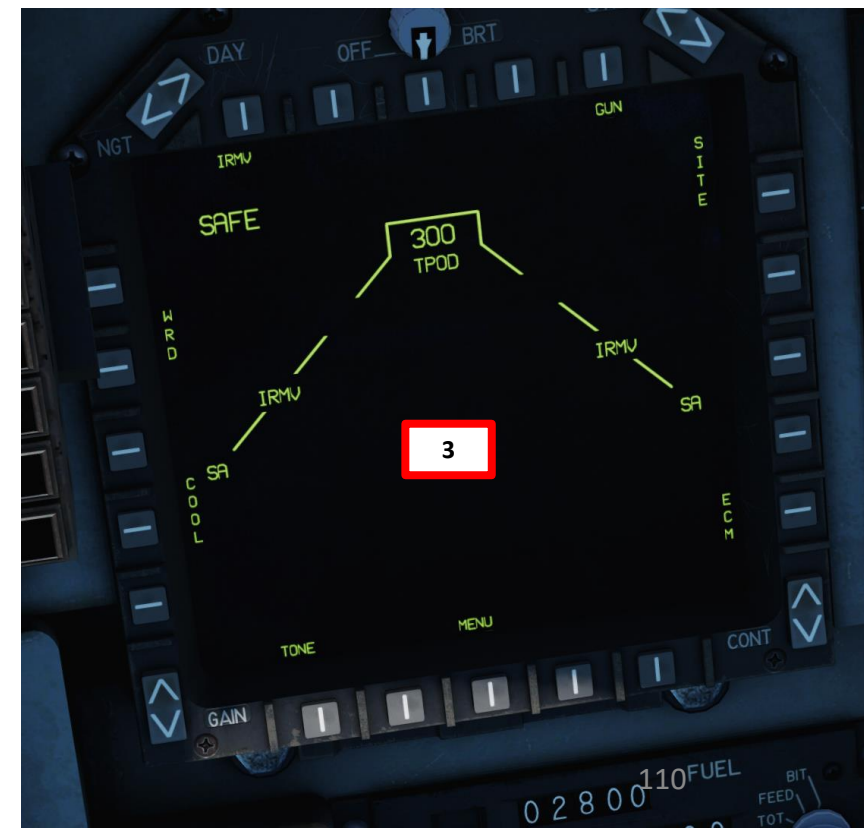

# 1 - WEIGHT CALCULATIONS

Note: Gross Weight is available from the VREST VL/VTO Sub-Menu (menu is only visible if the NAV Master Mode or A/G Master Mode is selected). It is the total weight of the aircraft including fuel, water, stores including hung stores, and rounds remaining including spent casings. The GWT is used to compute F+W. If displayed GWT is pilot entered, an asterisk (\*) is displayed to the left of GWT.

In a nutshell, check that the GWT value is smaller than 20,500 lbs.



GWT modified by pilot

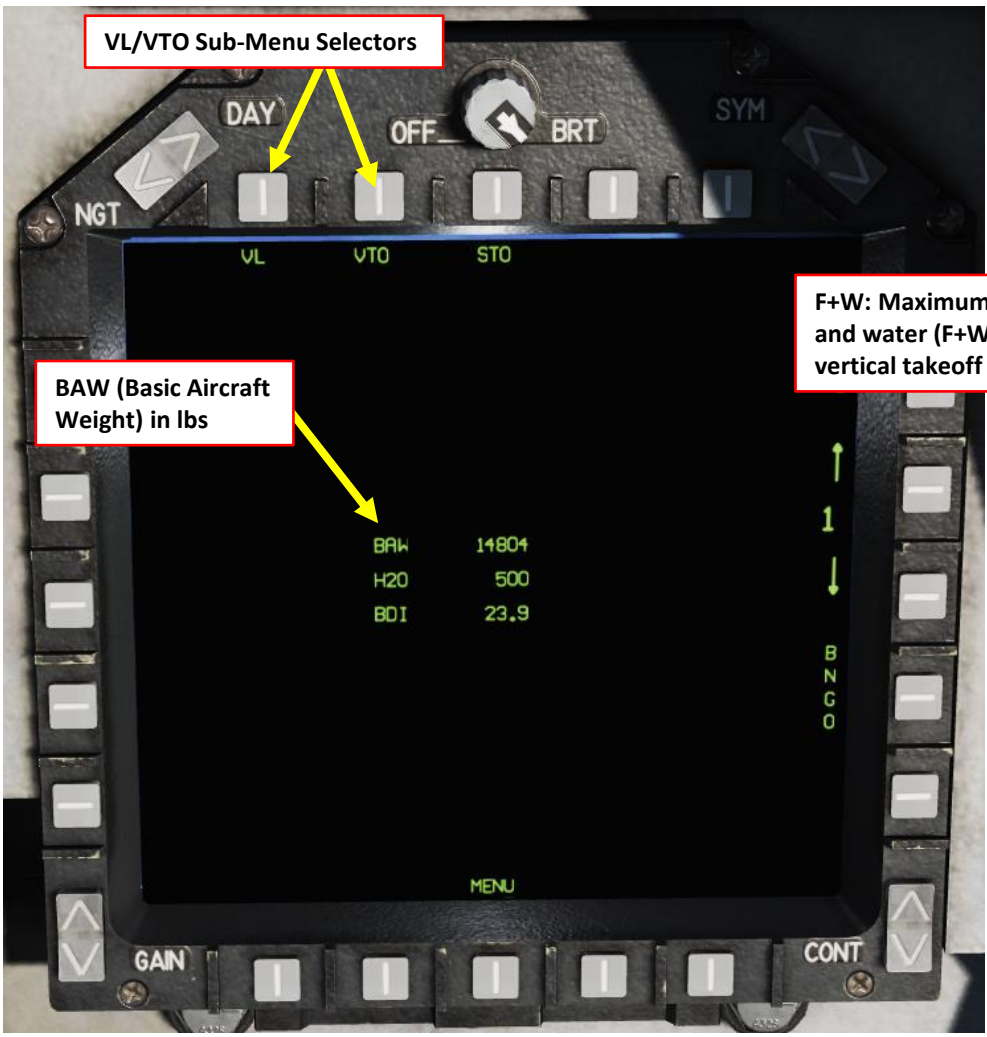

F+W: Maximum Weight of fuel and water (F+W) that permits a vertical takeoff or landing

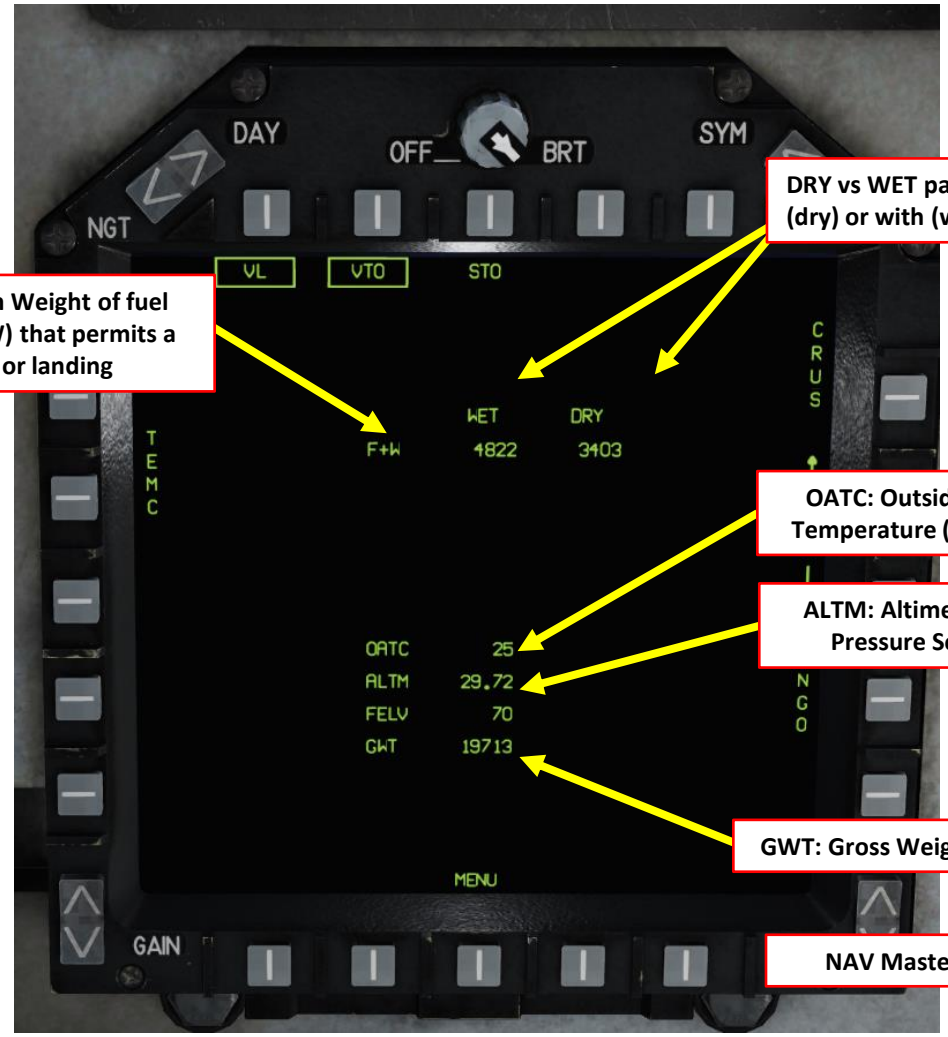

DRY vs WET parameter: without (dry) or with (wet) water injection

OATC: Outside Air Temperature (deg C)

ALTM: Altimeter Barometric Pressure Setting (in Hg)

GWT: Gross Weight (lbs)

NAV Master Mode



## 2 - STORES & FUEL JETTISON

If we take an example where we are 1500 lbs overweight, we can either:

- Fly until we burn the excess fuel
- Dump the excess fuel
- Jettison our weapons

Jettisoning expensive missiles may not be the best idea for the taxpayer... I'm just saying. Still, it's a simulator, so I'll show you how to dump fuel and jettison ordnance.

### Jettison Ordnance

1. Set the Jettison Control white knob to STA (Selected Stations)
2. Press the « SEL » buttons at the stations you wish to jettison (try to avoid having an asymmetric configuration)
3. Alternatively, you can set the Selective Jettison Control Knob to specific preset positions like FUEL to select automatically external fuel tanks.
4. Press the JETT red button to jettison.



### Selective Jettison Control

- STA: Selected stations
- STOR: Selected stores
- SAFE: Safety Position
- CMBT: Combat
- FUEL: External Fuel Tanks
- PUSHBUTTON: Jettisons selected ordnance

### Dump Fuel

- a. Calculate the Bingo Fuel you need to land: 4100 lbs – 1500 lbs = **2500 lbs**
- b. Set Bingo Fuel knob to 2500 lbs
- c. Set the Left and Right Fuel Dump switches FWD (DUMP)
- d. The fuel tanks will dump fuel until either BINGO FUEL target is reached or 2800 lbs remains (whichever comes first).
- e. Once d) is completed, Left and Right Fuel Dump Switches will automatically reset.

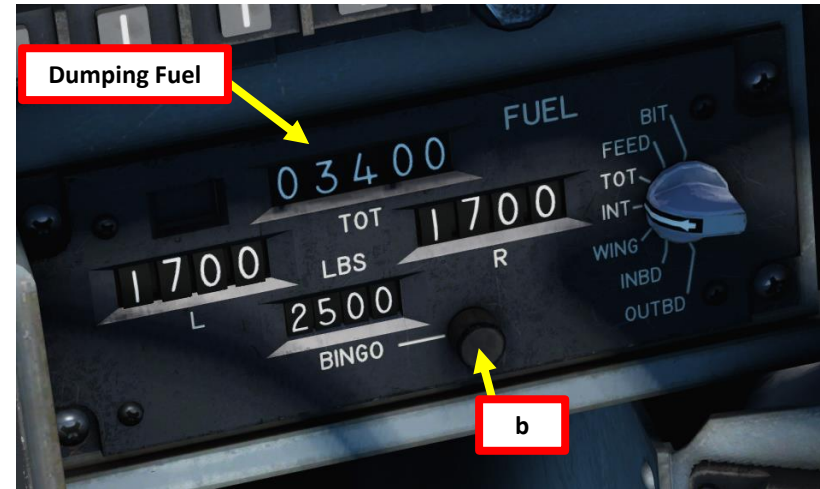

### 3 - LANDING TYPES

#### Conventional Landing (CL):

The CL requires substantially greater distance to stop than a SL or RVL. Landing distance available is a critical consideration when performing a CL. The brakes are designed primarily for V/STOL (Vertical/Short Takeoff & Landing) and are marginal for a CL without Power Nozzle Braking (PNB); therefore, always use PNB when performing a CL. CLs without using PNB is an emergency procedure only.

#### Slow Landing (SL):

The SL is used when aircraft gross weight is too high for a VL or RVL or to reduce engine stress. There are two basic types of Slow Landing: the Fixed Nozzle Slow Landing (FNSL) and the Variable Nozzle Slow Landing (VNSL).

- FNSL: The recommended slow landing technique is the Fixed Nozzle Slow Landing using STOL flaps. The use of AUTO flaps is recommended when crosswinds conditions are heavy or when dealing with high asymmetric store loadings.
- VNSL: It is used whenever the throttle needs to remain at a relatively constant setting throughout the approach, for example when the engine reliability is suspect

#### Rolling Vertical Landing (RVL):

The RVL should be used when the landing surface isn't long enough to support a SL, but the landing area cannot support a VL because it is subject to damage from heating or is a source of FOD (Foreign Object Damage).

#### Vertical Landing (VL):

The VL is commenced from a 50 to 60 feet AGL hover. Landing should be made pointing into the wind to minimize exhaust reingestion.



# 4 - CONVENTIONAL LANDING (CL)

## Approach Checklist

1. Set Anti-Skid Switch to ON (Middle Position)
2. Select VSTOL (Vertical Short Takeoff & Landing) Master Mode Switch
3. STO STOP lever – CLEAR
4. Set Nozzle Position lever – 0 deg
5. Set flaps to AUTO
6. Set Water Injection switch – OFF (MIDDLE)

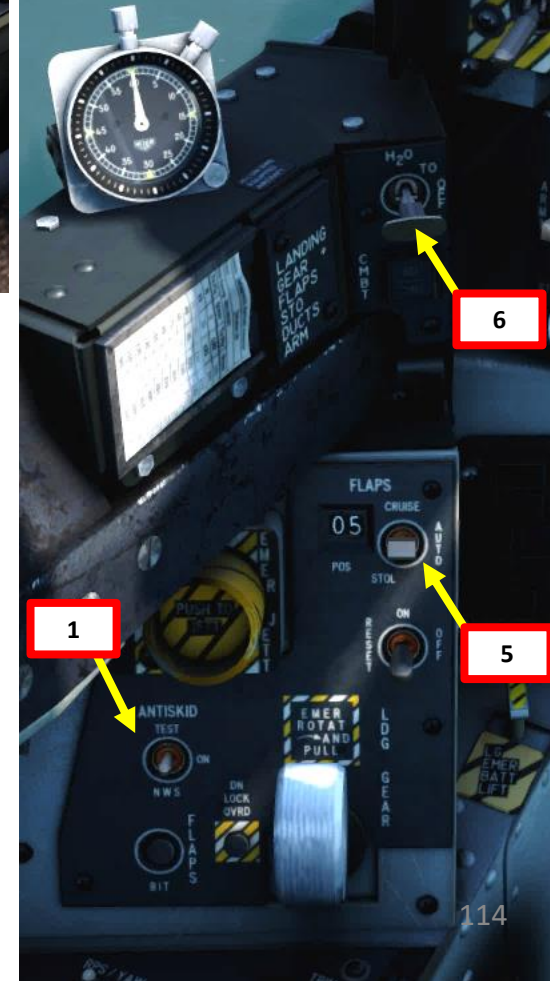
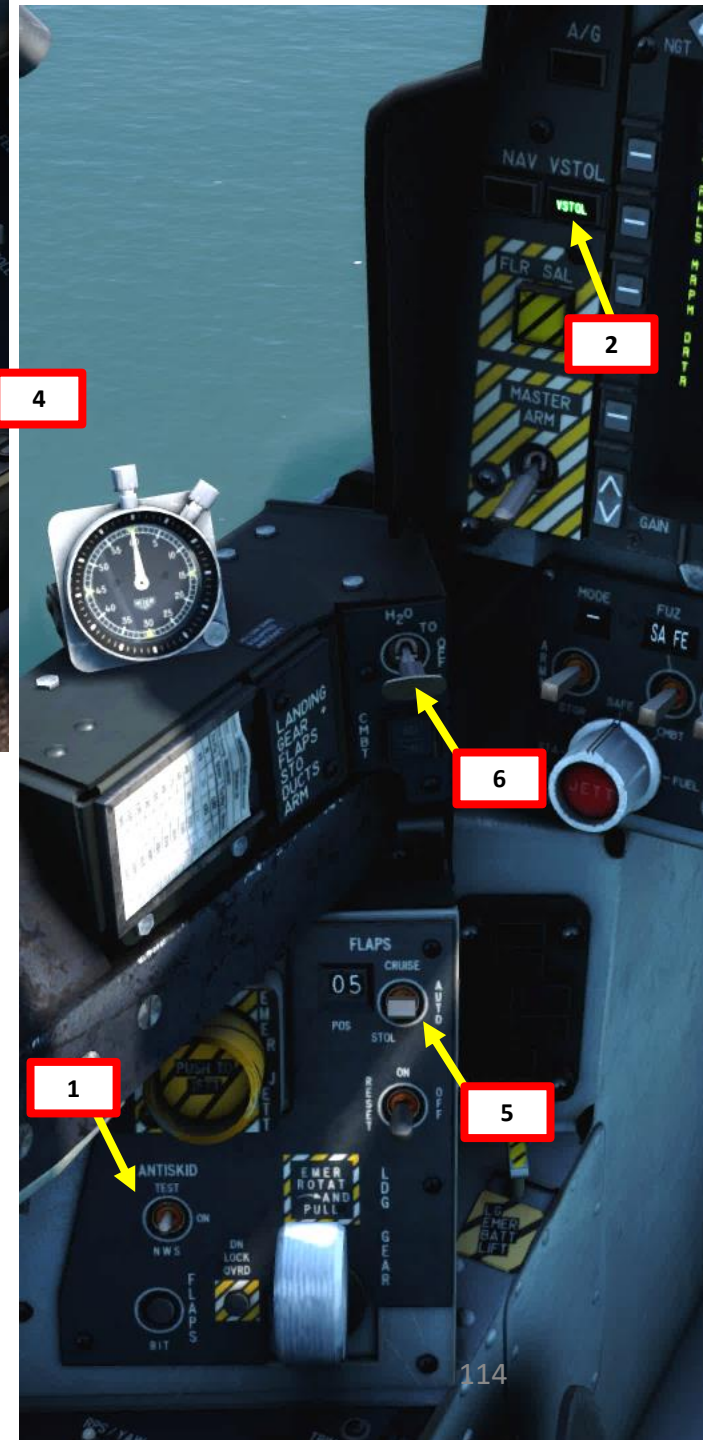
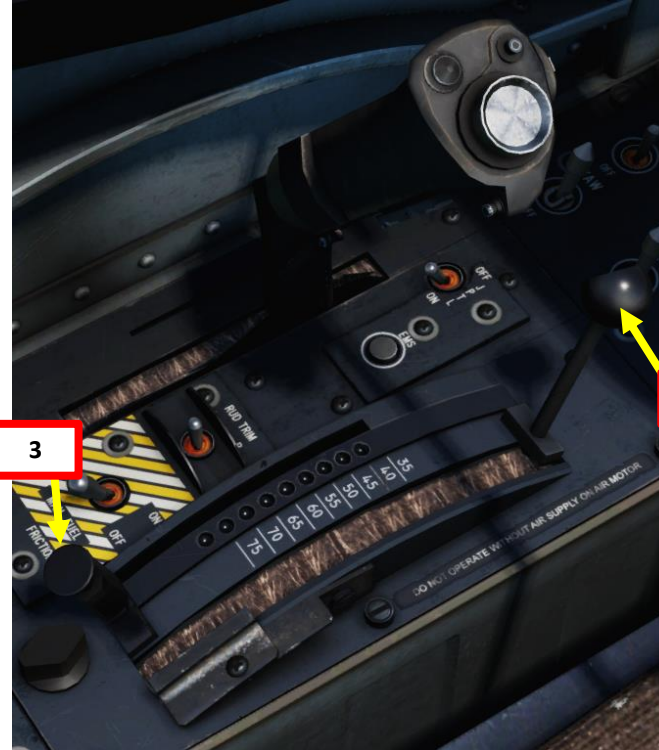
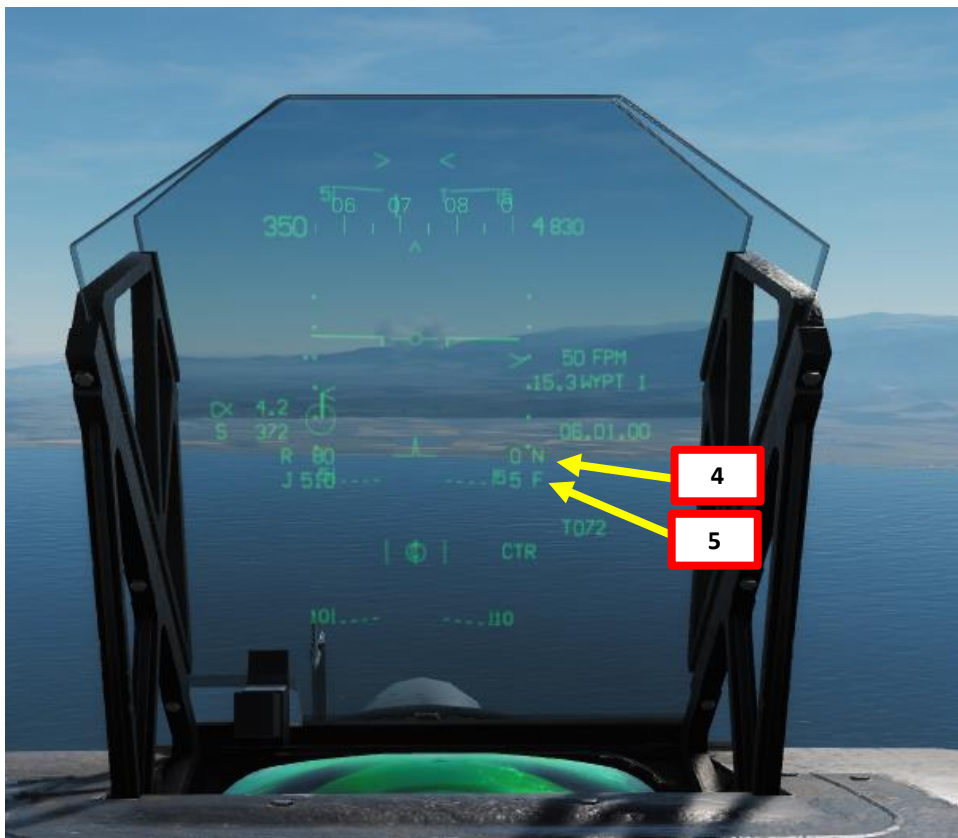

# 4 - CONVENTIONAL LANDING (CL)

## Landing Checklist (Overhead Break)

7. Fly at 800 ft AGL, 350 kts over the runway.
8. At the Break Point, perform a 4 G level turn, intercept 10 units of AoA (Angle of Attack), and exit turn at 250 kts
9. Descend to 600 ft AGL, set landing gear down, verify flaps are set to AUTO.
10. Keep about 10-12 units of AoA (use throttle to control the AoA) and descend to 200 ft AGL on Final
11. Set Flight Path Vector on end of runway. At 30 to 50 ft AGL: Set Witches Hat 2 degrees above the horizon and control rate of descent with throttle.
12. Touchdown when reaching runway threshold and cut throttle to slow down.
13. Engage Nosewheel Steering HOTAS button when rolling straight and pedals are neutralized



## OVERHEAD BREAK

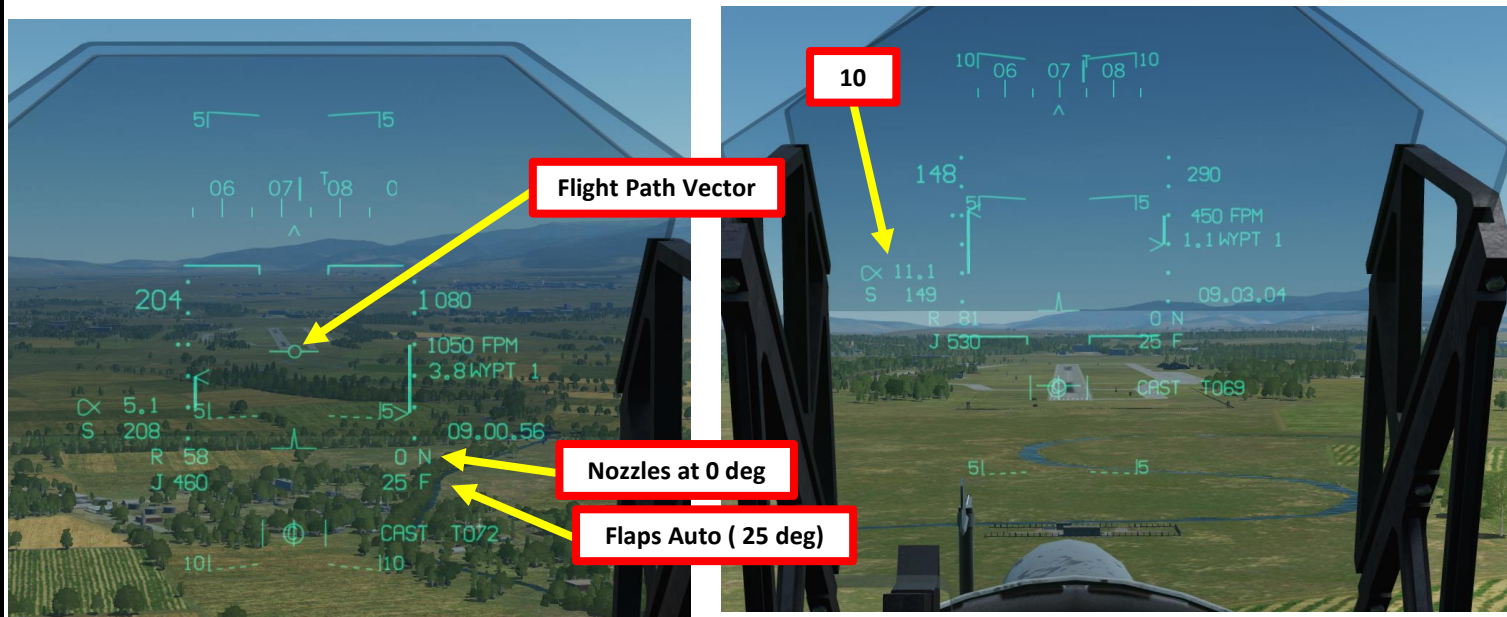
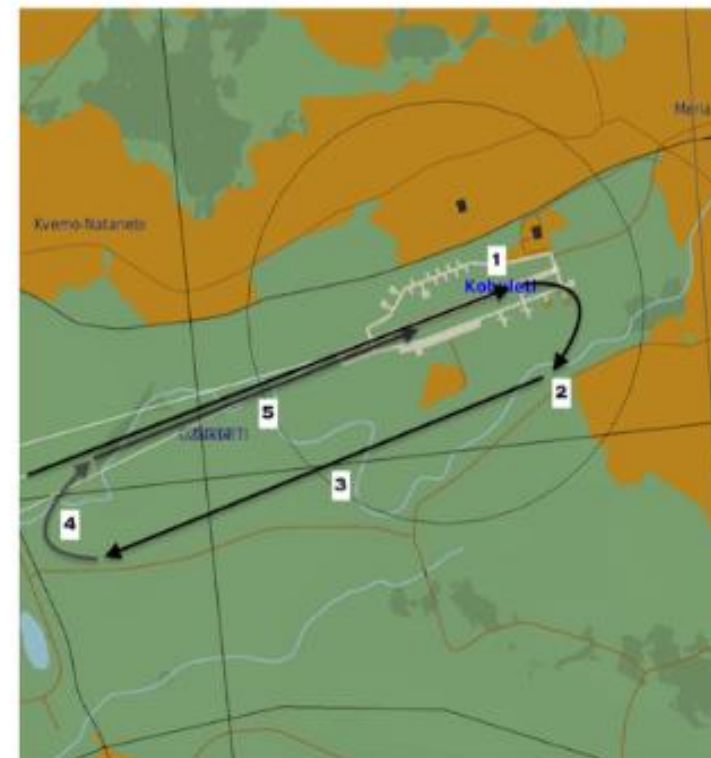

4 - CONVENTIONAL LANDING  
(CL)

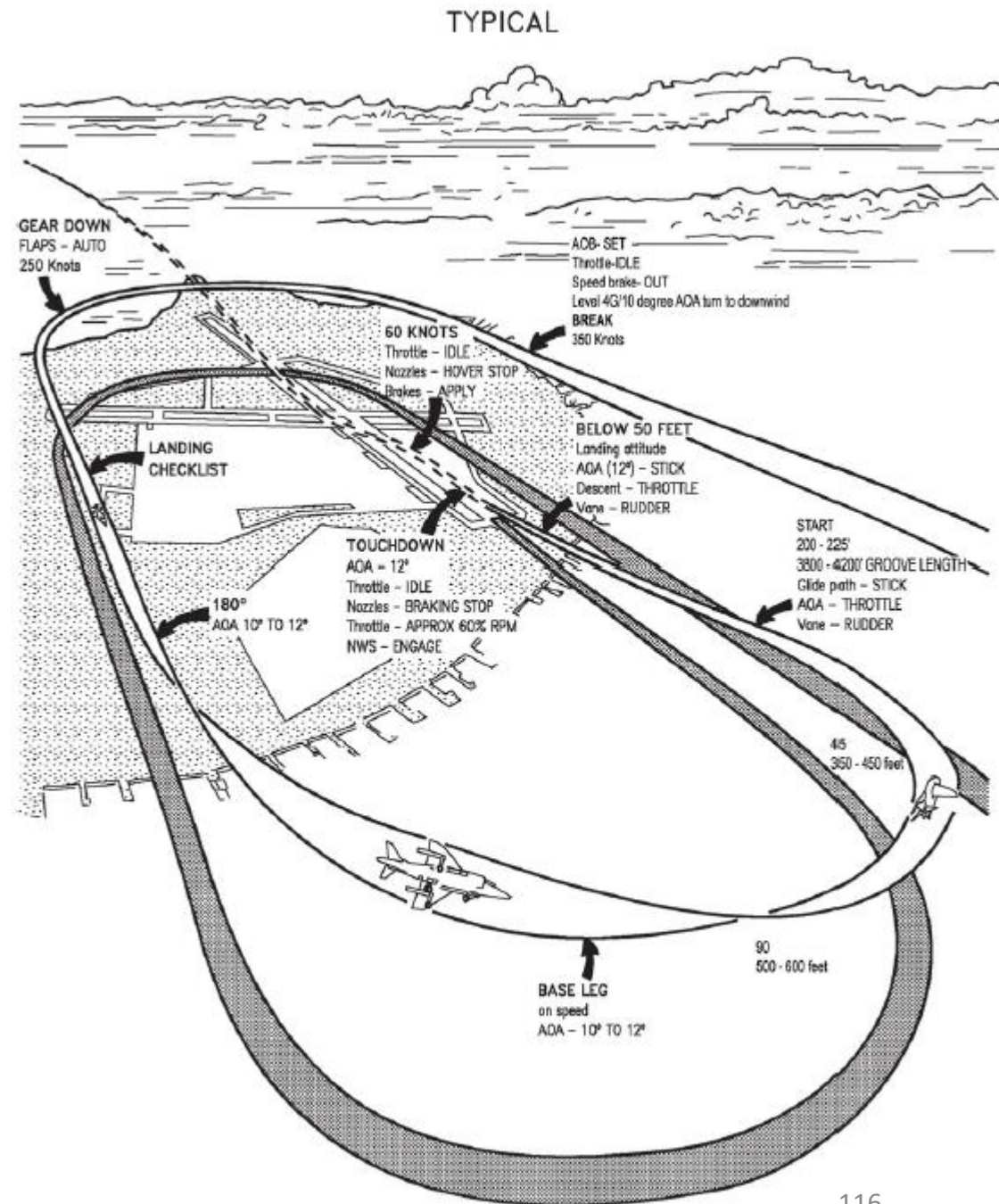
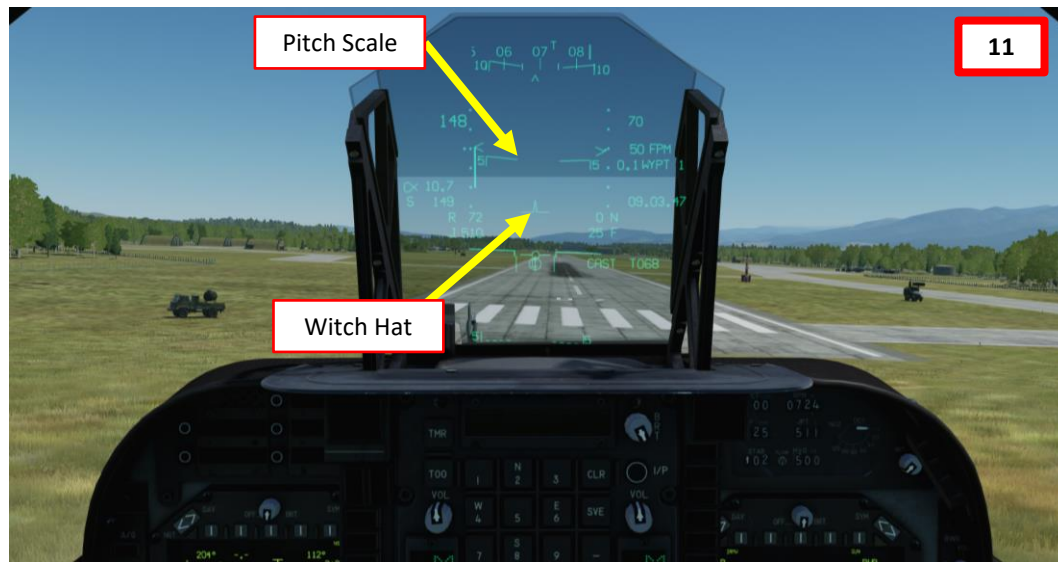

5 - SLOW LANDING (SL)  
VARIABLE NOZZLE

TYPICAL

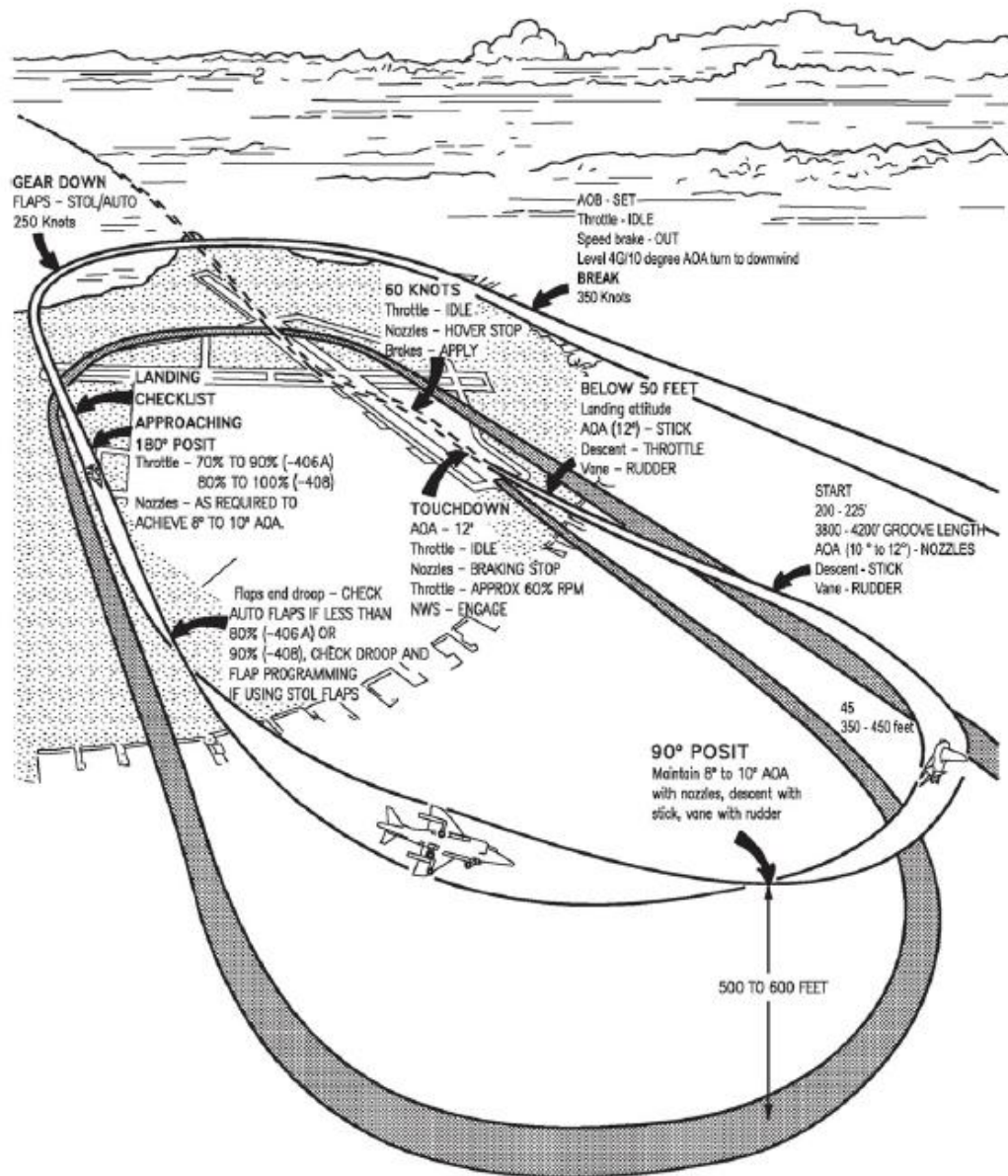

6 - SLOW LANDING (SL)  
FIXED NOZZLE

TYPICAL

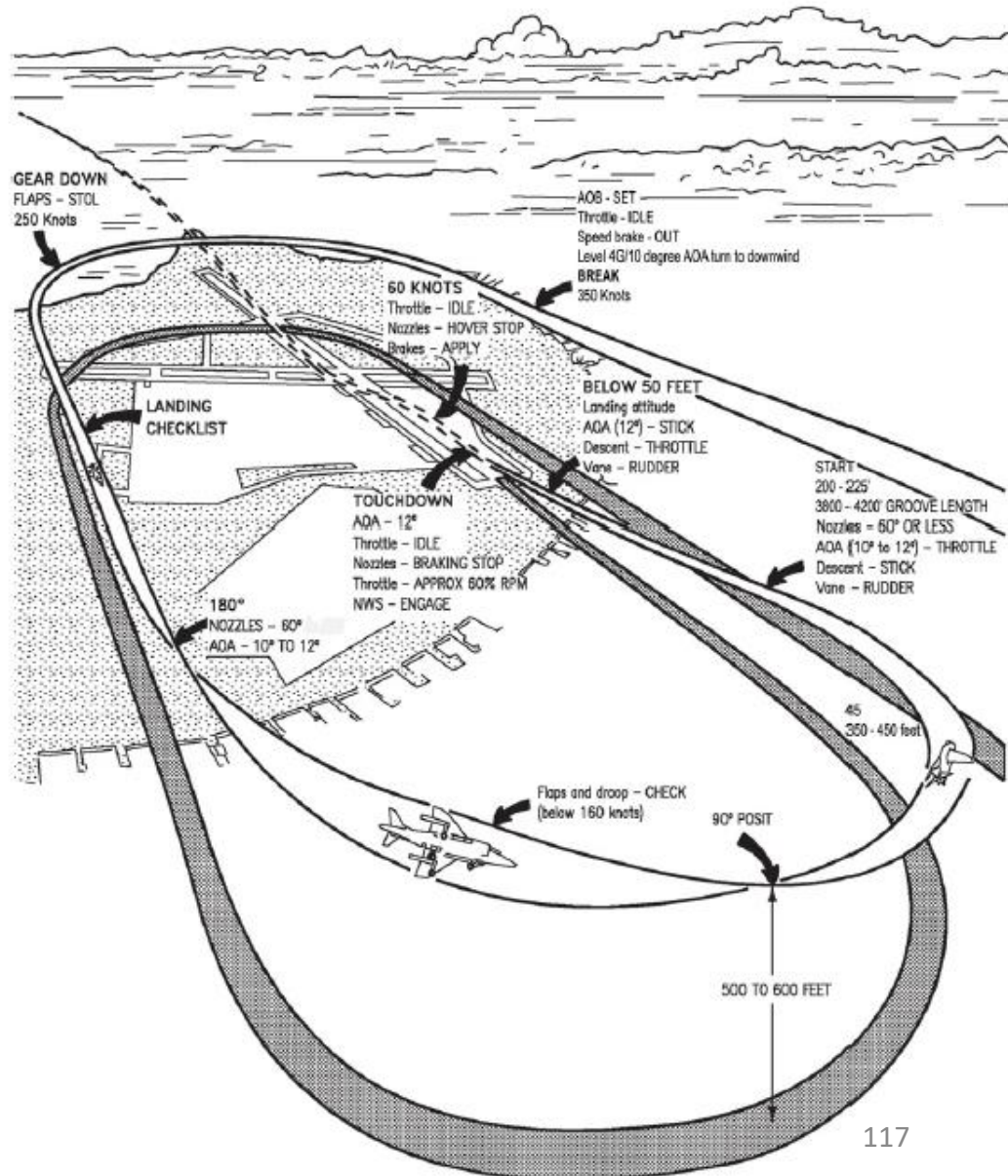

# 7 – ROLLING VERTICAL LANDING (RVL)

**Note:** If your aircraft exceeds the Vertical Landing Weight (VL) or 20,500 lbs by as much as 4000 lbs, you may conduct a Rolling Vertical Takeoff as fast as 70 kts at touchdown in order to augment your engine power with lift generated by the Harrier's wing. RVLs are not to be used on ships.

1. Make sure the V/STOL Master Mode button is active and the VREST page is accessible from the MPCD main menu, then select VREST (Vertical/Short Takeoff & Landing, Range, Endurance, Speed & Time) page.
2. Press OSB next to "STO" to select "Short Takeoff" sub-page.
3. Check GWT (Gross Weight) of aircraft and determine your touchdown speed based on it. In our case, our weight is almost 24000 lbs, so we will use a Touchdown Speed of 65 kts.
4. Set Altimeter Mode to Radar Altimeter
5. Set Anti-Skid Switch to ON (Middle Position)
6. Set Landing Gear DOWN
7. STO STOP lever – CLEAR
8. Set Nozzle Position lever – 60 deg
9. Set flaps to STOL
10. Set Water Injection switch – LANDING (DOWN)

TOUCHDOWN SPEED (KCAS)	MAXIMUM RVL WEIGHT
Below or at 45 knots	VL weight (max 20 500 lbs)
50 knots	VL + 2 300 lbs
55 knots	VL + 2 700 lbs
60 knots	VL + 3 100 lbs
65 knots	VL + 3 500 lbs
70 knots	VL + 4 000 lbs

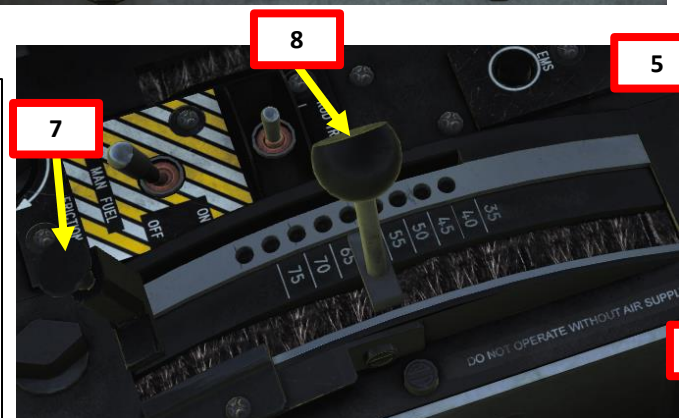
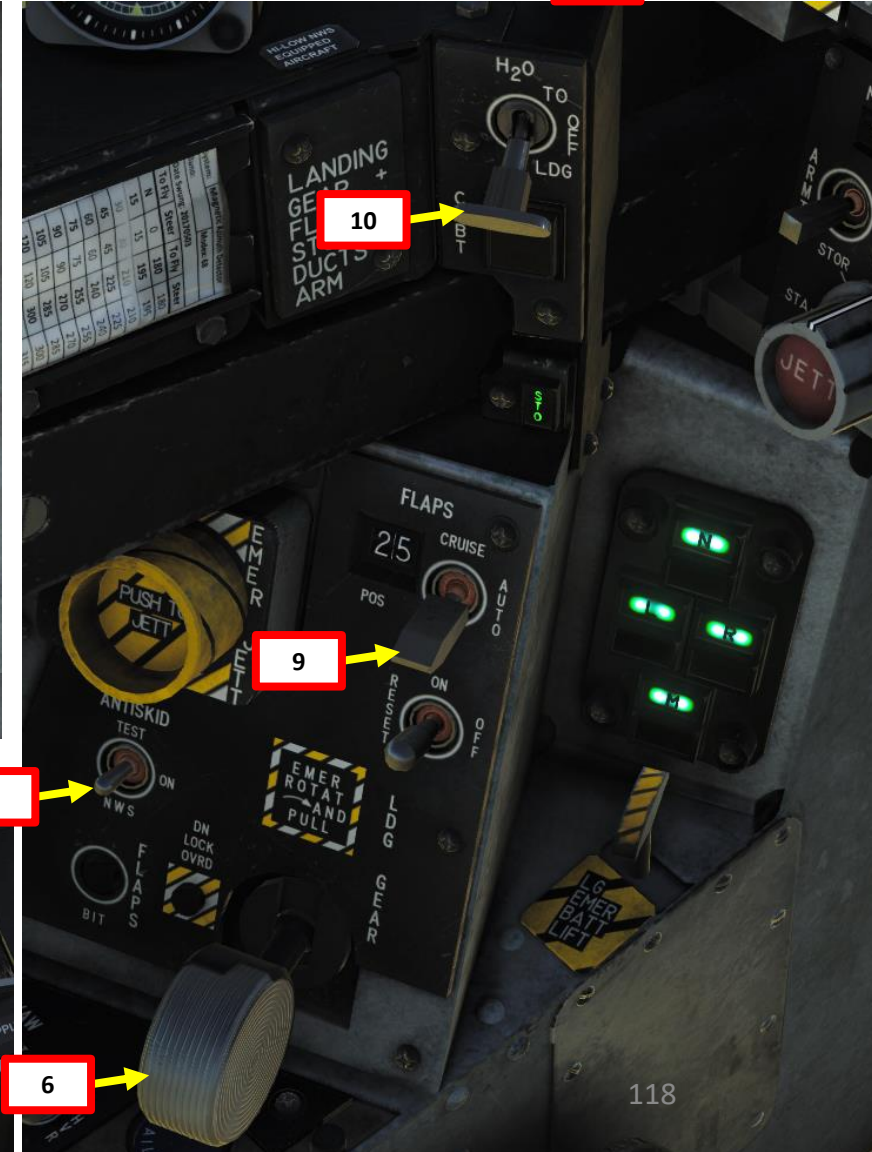
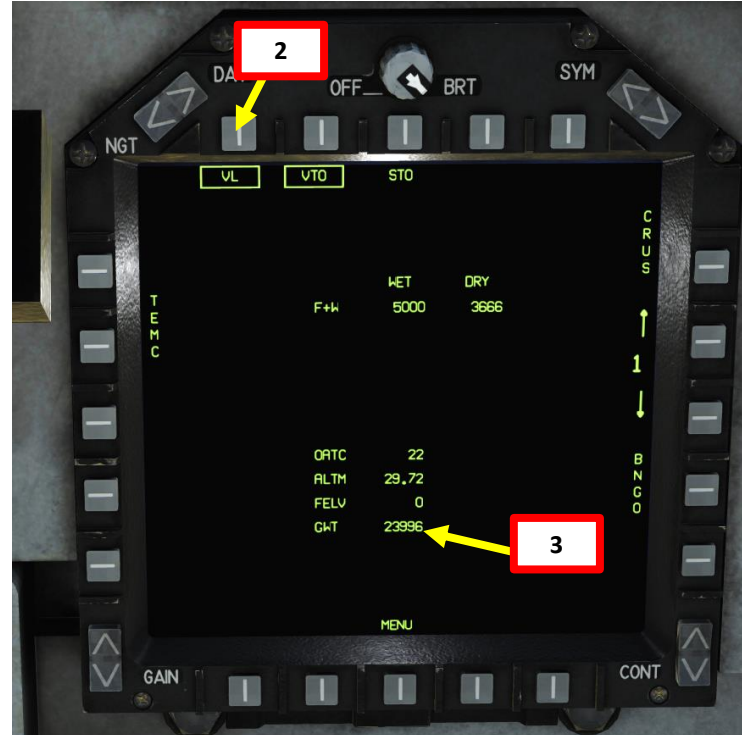
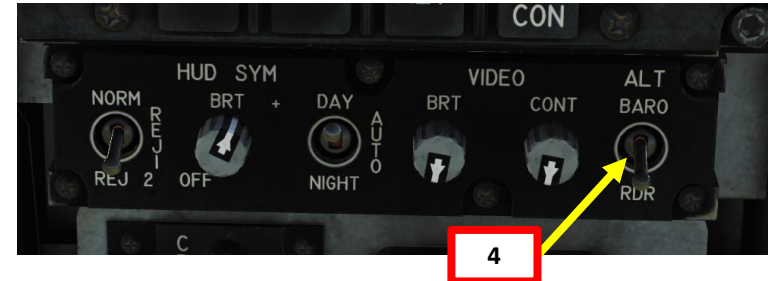

## 7 – ROLLING VERTICAL LANDING (RVL)

11. Approach the Key (reference point half a nautical mile from landing site) straight in at an altitude of 325 ft AGL. Make sure to adjust rudder to keep the Wind Sideslip Vane straight (land into the wind).
12. At the Key, adjust aircraft attitude to set the Witch Hat on the horizon, adjust nozzles to maintain touchdown speed (65 kts) and adjust power to maintain the desired glideslope of 5 deg. Your rate of descent should not exceed 300-400 ft/min.
13. When on the ground, set throttle to IDLE, use your brakes and set nozzles fully aft.

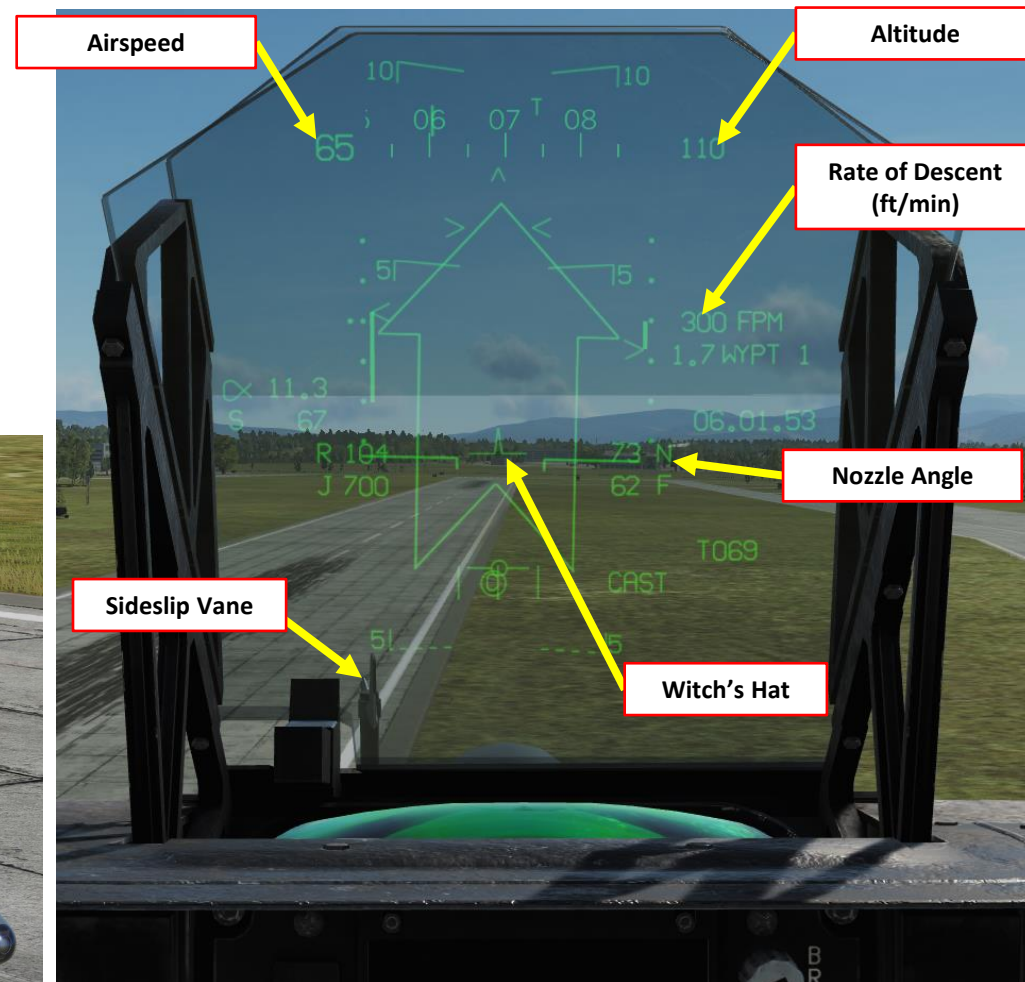

# 8 - VERTICAL LANDING (VL)

**Note:** For vertical landings, your aircraft must not exceed a weight of 20,500 lbs.

1. Make sure the V/STOL Master Mode button is active and the VREST page is accessible from the MPCD main menu, then select VREST (Vertical/Short Takeoff & Landing, Range, Endurance, Speed & Time) page.
2. Press OSB next to “VL” to select “Vertical Takeoff” sub-page.
3. Check GWT (Gross Weight) of aircraft and confirm that you do not exceed landing weight.
4. Set Altimeter Mode to Radar Altimeter
5. Set Anti-Skid Switch to ON (Middle Position)
6. Set Landing Gear DOWN
7. STO STOP lever – CLEAR
8. Set Nozzle Position lever – 60 deg
9. Set flaps to STOL
10. Set Water Injection switch – LANDING (DOWN)
11. STO STOP lever – CLEAR
12. For the approach, set Nozzle Position lever – 60 deg

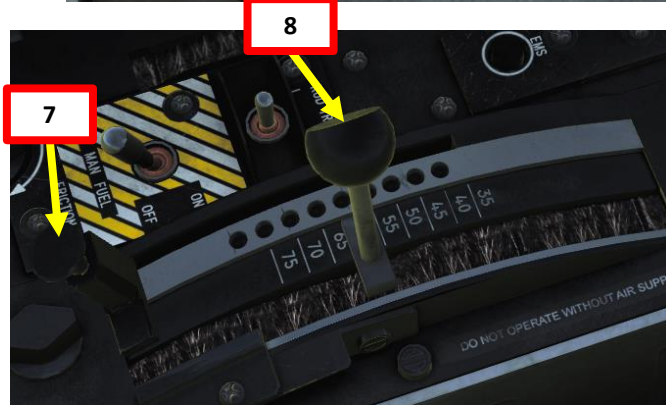
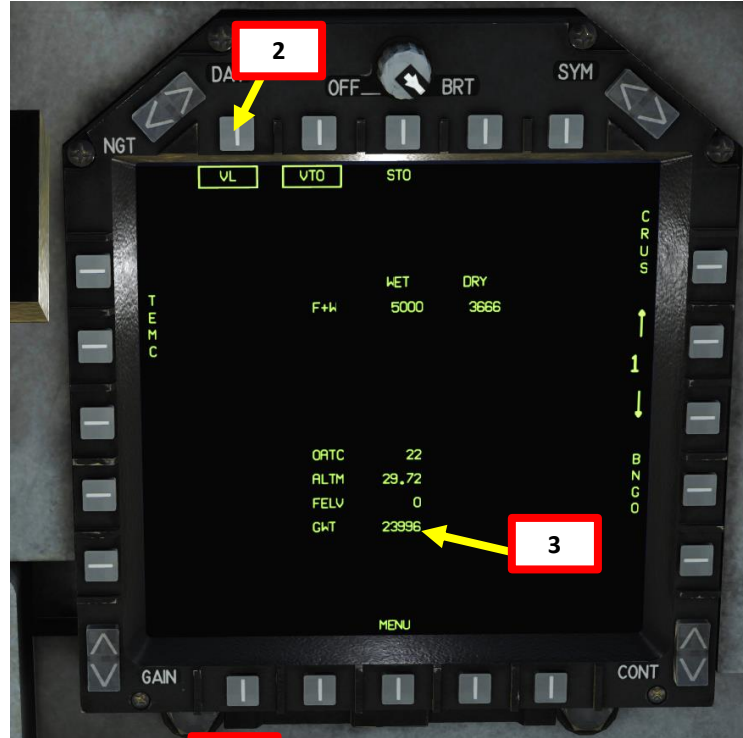
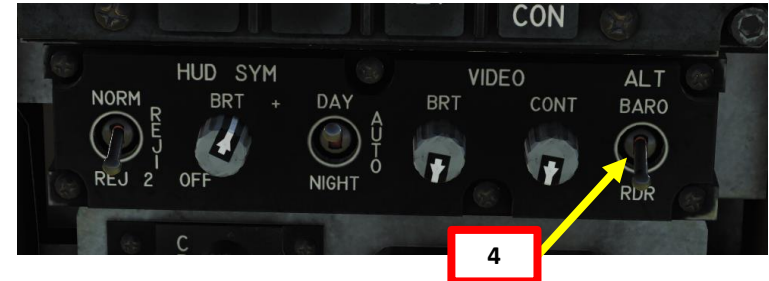

# 8 - VERTICAL LANDING (VL)

13. Approach the Key (reference point half a nautical mile from landing site) straight in at an altitude of 325 ft AGL. Make sure to adjust rudder to keep the Wind Sideslip Vane straight (land into the wind).
14. At the Key, set Nozzles to 82 deg.
15. Flare slightly to slow down to 50 kts and adjust aircraft attitude to set the Witch Hat on the horizon. Gradually slow down the aircraft to a hover.
16. Once set in a hover, gently reduce power to land. Your rate of descent should not exceed 300-400 ft/min.
17. At 20 ft, the aircraft will come into ground effect.
18. When on the ground, set throttle to IDLE, use your brakes and set nozzles fully aft.

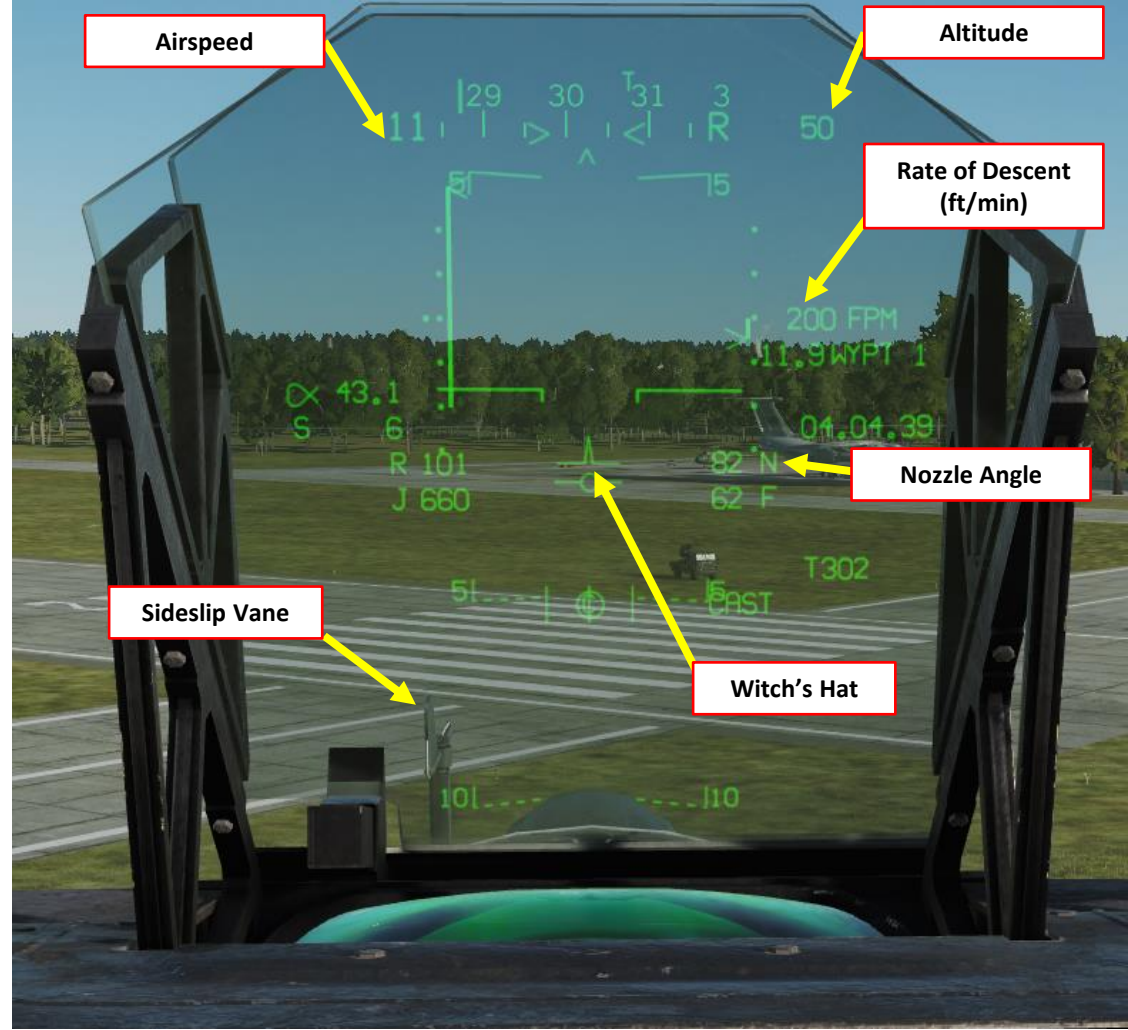

8 - VERTICAL LANDING (VL)

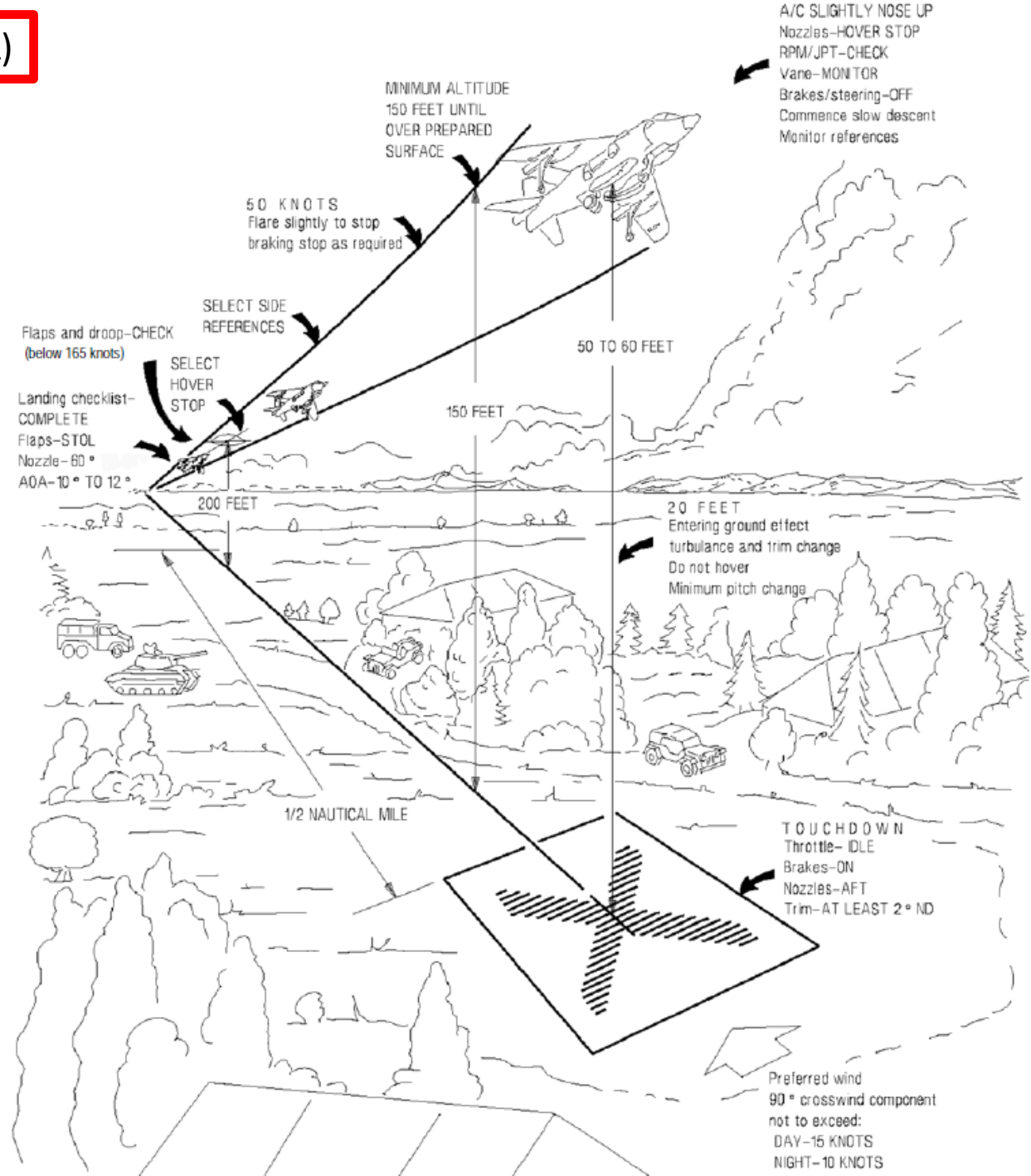

# 9 - CASE I RECOVERY

Case I Recovery Procedure (taken from Baltic Dragon's Training Case I Recovery Mission).



## TACAN PRIMARY MARSHAL

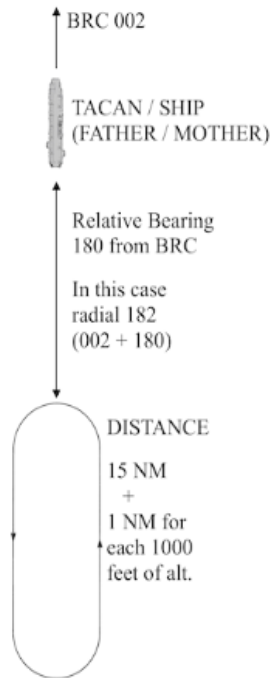

TACAN primary marshal is oriented on the 180 bearing relative to the BRC. That means it is exactly behind the ship. To determine it, you simply add the BRC to 180 (or subtract, if the BRC is greater than 180). Examples:

If BRC is 090, then TPM will be at radial 270  
 If BRC is 270, then TPM will be at radial 090

The distance is calculated as follows:

For each 1000 feet of altitude add 1NM to the base of 15 NM, which will give you the distance from the Mother to the holding fix.

So if you are told to hold at angels 7, your holding fix will be 22 NM (15 + 7) behind the ship on the given radial.

TIP: to easily determine that point, use the TACAN offset function and enter desired BEARING and DISTANCE, calculated as described above.



## DAY CASE I PROCEDURE

### Part 1

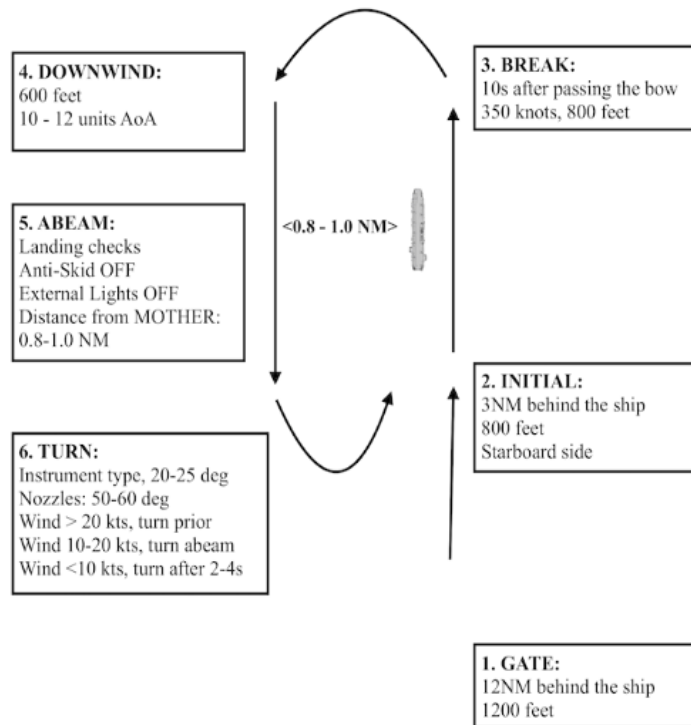

## DAY CASE I PROCEDURE

### Part 2

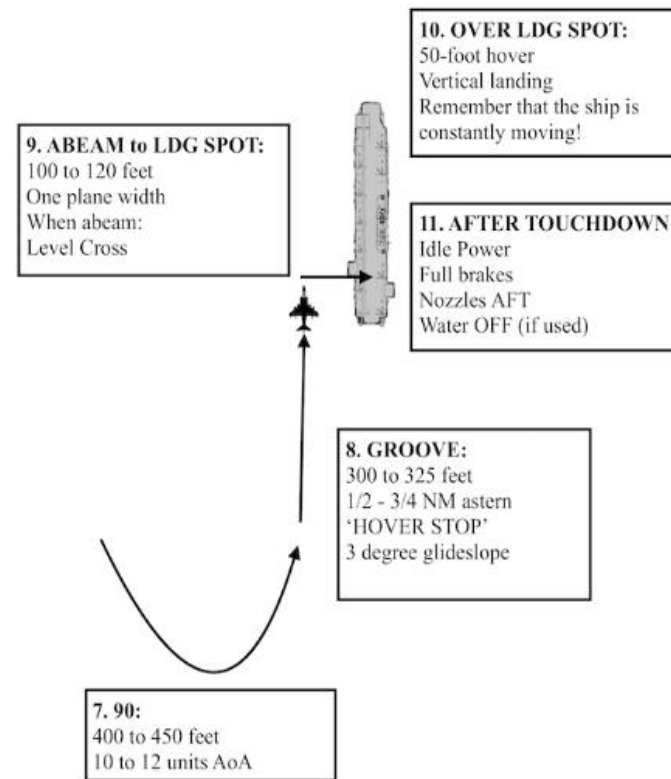

## 9 - CASE I RECOVERY

**Note:** For vertical landings, your aircraft must not exceed a weight of 20,500 lbs.

1. Make sure the V/STOL Master Mode button is active and the VREST page is accessible from the MPCD main menu, then select VREST (Vertical/Short Takeoff & Landing, Range, Endurance, Speed & Time) page.
2. Press OSB next to “VL” to select “Vertical Takeoff” sub-page.
3. Check GWT (Gross Weight) of aircraft and confirm that you do not exceed landing weight.

### Before being in the Groove, you should:

4. Set Altimeter Mode to Radar Altimeter
5. Set Anti-Skid Switch to OFF (Down/NWS, very important!)
6. Set Landing Gear DOWN
7. STO STOP lever – CLEAR
8. Set Nozzle Position lever – 60 deg
9. Set flaps to STOL
10. Set Water Injection switch – LANDING (DOWN)
11. STO STOP lever – CLEAR
12. For the approach, set Nozzle Position lever – 60 deg

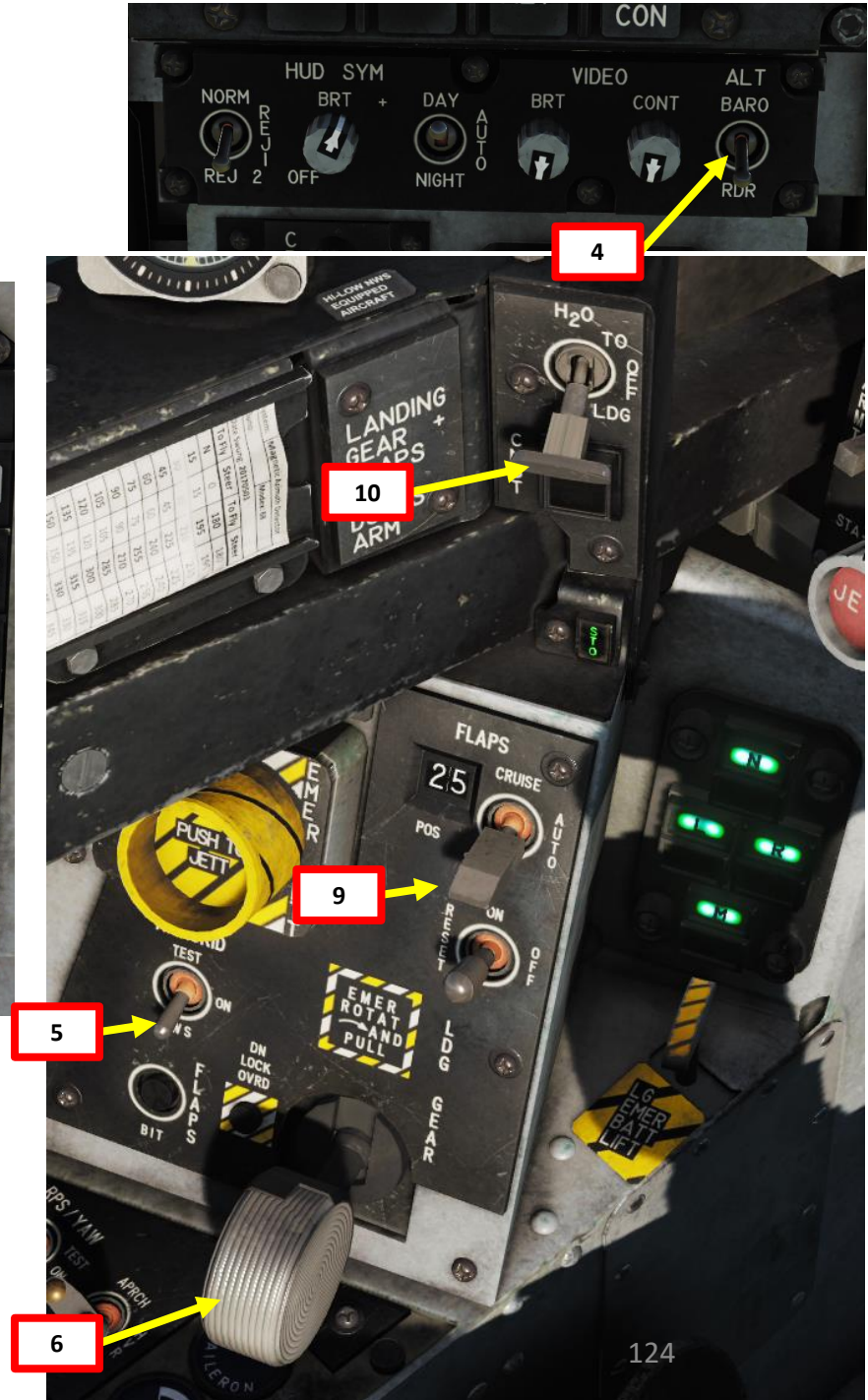
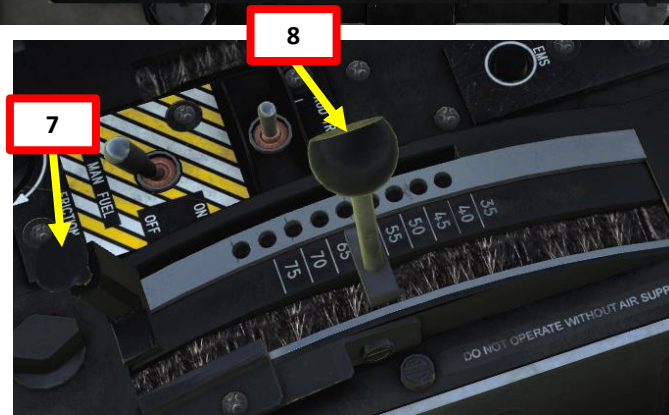
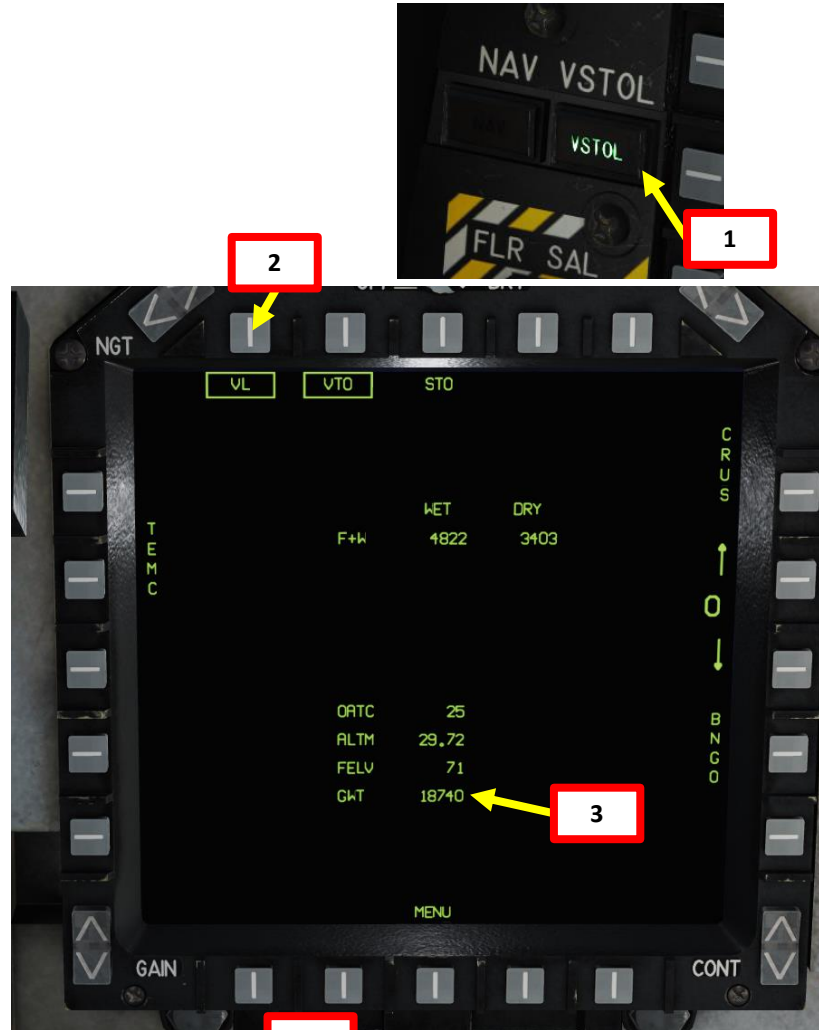

## 9 - CASE I RECOVERY

### When entering the Groove:

13. Enter the Groove (Final) at approx. 300-325 ft
14. As you slow down at 130-140 kts, level off at 150 ft to avoid sinking and set Nozzle Position lever – 82 deg
15. Keep the aircraft between 1/2 and 3/4 nm astern of the ship. You should be flying in formation with the ship at that point.
16. Fly abeam of the landing spot at an altitude of 100-120 ft, then use rudder to move laterally while remaining level (“Level Cross”).
17. Monitor constantly your variometer (sink rate in feet per minute), your Jet Pipe Temperature (J) and your engine RPM (R) in order to not exceed limitations.
18. Gently reduce power to land. Your rate of descent should not exceed 300-400 ft/min.
19. At 20 ft, the aircraft will come into ground effect.
20. When on the deck, set throttle to IDLE, use your brakes and set nozzles fully aft.



Aircraft always flies abeam the ship



9 - CASE I RECOVERY



# PEGASUS ENGINE

The AV-8B N/A also fields an updated version of the **Rolls-Royce Pegasus 11-61** (F402-RR-408) vectored-thrust turbofan engine.

In the 1950's, there was a perceived need for combat runways for takeoff and landing, and which could, if required, be dispersed for operation from unprepared and concealed sites. Naval interest focused on a similar objective to enable shipborne combat aircraft to operate from helicopter-size platforms and small ships, because of the high cost and expected vulnerability of large aircraft carriers. During the 1950s, numerous projects and research programs were initiated in the United States and Western Europe to study and validate alternative means of achieving the required short or vertical takeoff (VTO) and landing characteristics. One of the answers of the industry to this concern for short runway requirements resulted in the Pegasus.

Originally designed by Bristol Siddeley, the Pegasus was manufactured by Rolls-Royce plc and was not only able to power a jet aircraft forward, but also to direct thrust downwards via four swivelling nozzles. Lightly loaded aircraft equipped with this engine can manoeuvre like a helicopter. In particular, they can perform vertical takeoffs and landings. The Pegasus features three low pressure (LP) and eight high pressure (HP) compressor stages driven by two LP and two HP turbine stages respectively. The Pegasus 11-61 (MK.107, aka -408) is the latest and most power version of the Pegasus, providing 23,800 lbf (406 kN).

Unusually, the LP and HP spools rotate in opposite directions to greatly reduce the gyroscopic effects which would otherwise hamper low speed handling. LP and HP fan blading is made of titanium, and the LP fan blades operate in the partly supersonic region. Engine starting is done by a top-mounted packaged combined gas turbine starter/APU.

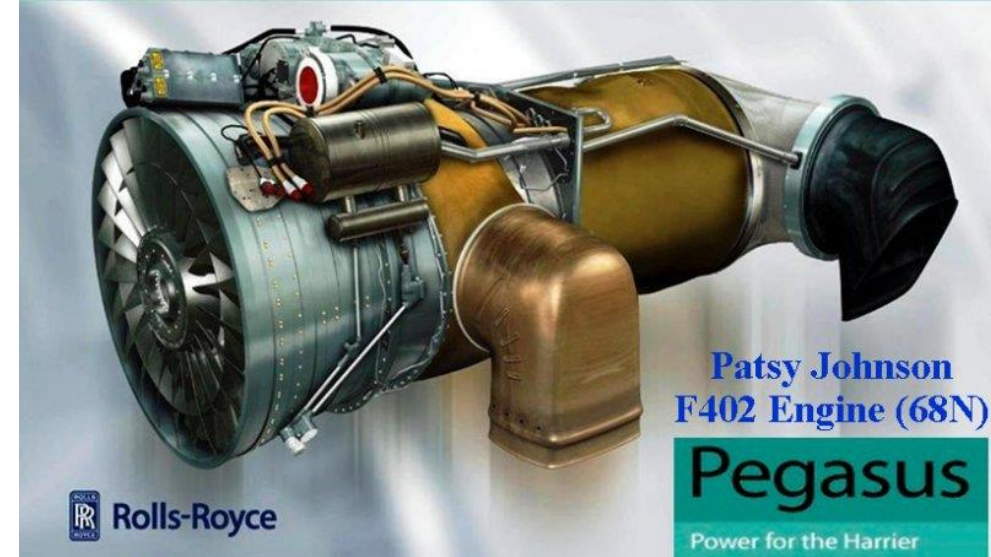
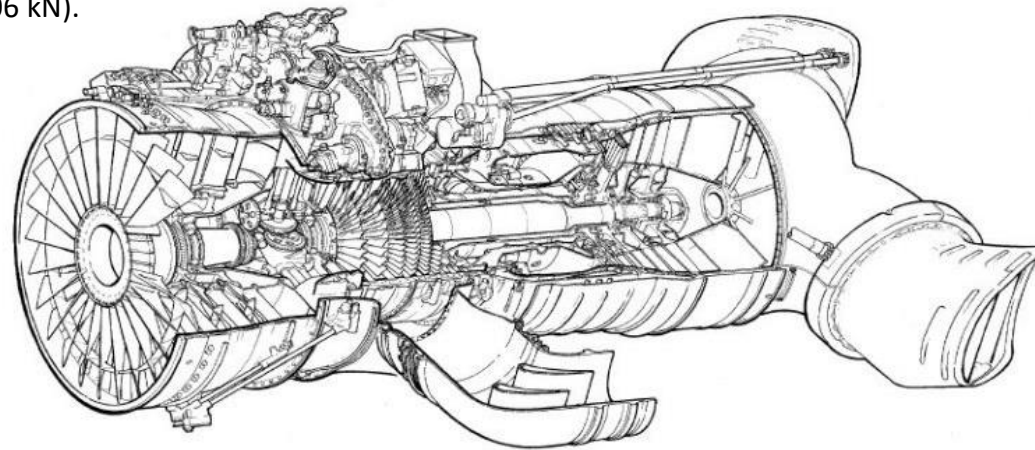

### AIR BLEEDS—3rd STAGE LP

- ENGINE BAY VENTILATION
- REAR NOZZLE BEARING COOLING
- PRECOOLER-COOLANT FOR 6TH STAGE BLEED (-408/-408A NON RADAR)
- PRECOOLER-COOLANT FOR 8th STAGE BLEED AIR (-408A RADAR ONLY)

### AIR BLEEDS—8th STAGE HP

- REACTION CONTROLS PD
- ON-BOARD OXYGEN P3 GENERATING SYSTEM PD
- 25mm GUN SYSTEM
- EQUIPMENT BAY AND COCKPIT CONDITION (-408A RADAR ONLY)

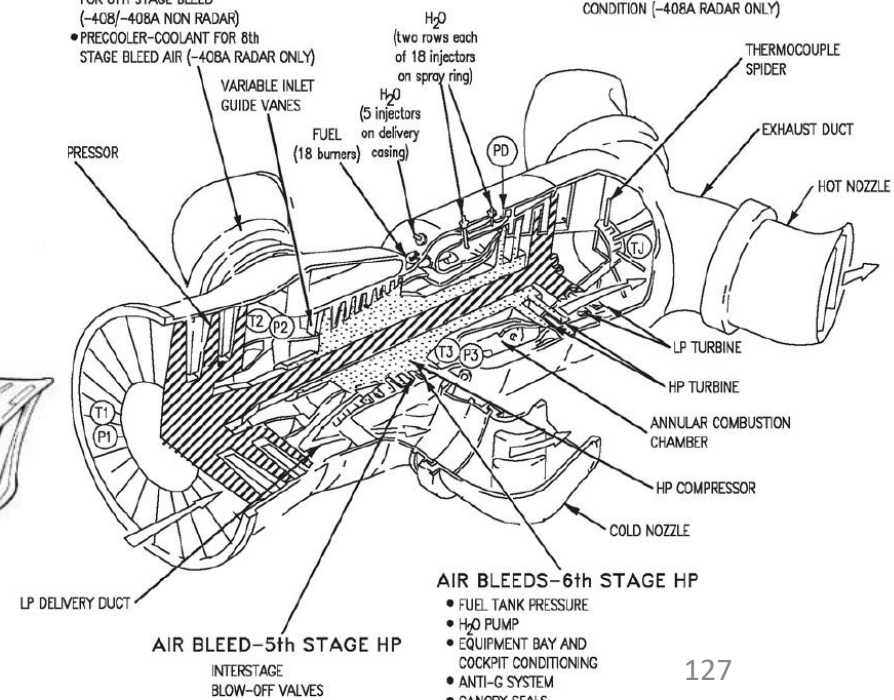

- ### AIR BLEEDS—6th STAGE HP
- FUEL TANK PRESSURE
  - H<sub>2</sub>O PUMP
  - EQUIPMENT BAY AND COCKPIT CONDITIONING
  - ANTI-G SYSTEM
  - CANOPY SEALS
  - ENGINE NOZZLE DRIVE

# ENGINE PARAMETERS

The Pegasus engine has multiple engine parameters. Engine RPM and Jet Pipe Temperature (JPT) can be monitored on the Heads-Up Display if the VSTOL Master Mode is ON.



- Duct Pressure (PSI)
- Fuel Flow (ppm)
- Jet Pipe Temperature (JPT) (deg C)



**Engine RPM (%)**

- Shows FAN RPM if ENG RPM switch is set to LOW
- Shows COMP RPM if ENG RPM switch is set to HIGH

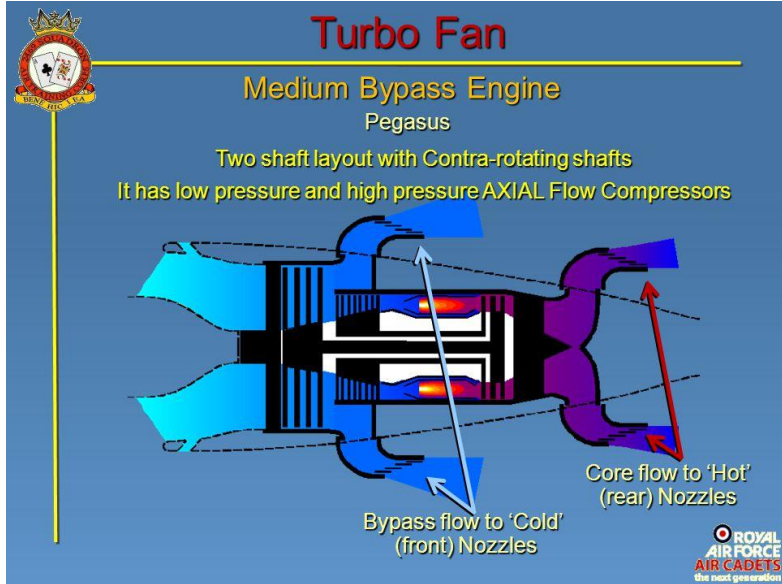

- SORTIE JPT:** Engine Outlet Jet Pipe Temperature
- Max JPT:** Maximum Jet Pipe Temperature allowable
- OT TIME:** Time available while in overtemperature
- IGV:** Inlet Guide Vane Position (deg). IGVs may be visualized as a valve controlling corrected air mass flow into the high pressure compressor.
- COMP RPM:** Low Pressure Compressor Speed
- FAN RPM:** Bypass Fan Speed
- JPT:** Jet Pipe Temperature
- COR COMP:** High Pressure Compressor Speed (Engine Core)
- COR FAN:** High Pressure Fan Speed (Engine Core)
- FUEL WT:** Fuel Weight (lbs)

**Water Injection Flow (Illuminated = Active)**

**Nozzle Angle**  
**Water (H2O) Quantity (lbs)**



**ENG MPCD Page**

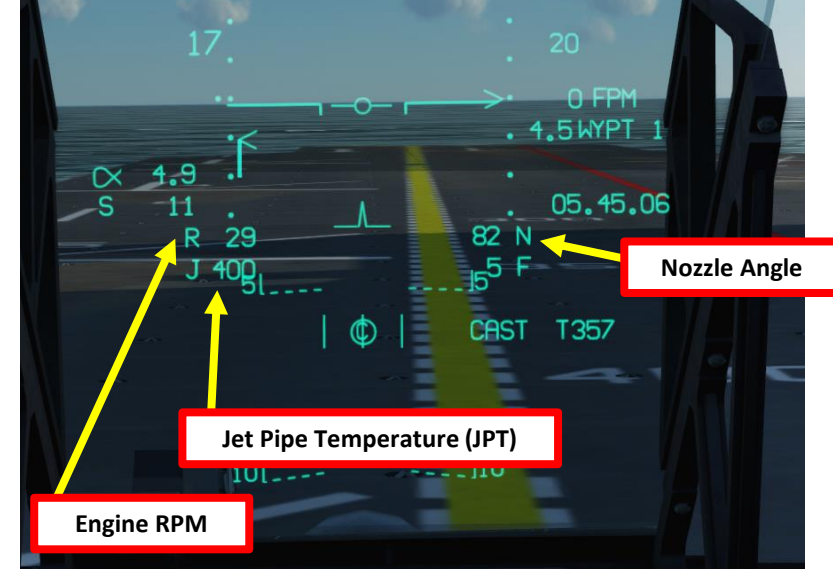
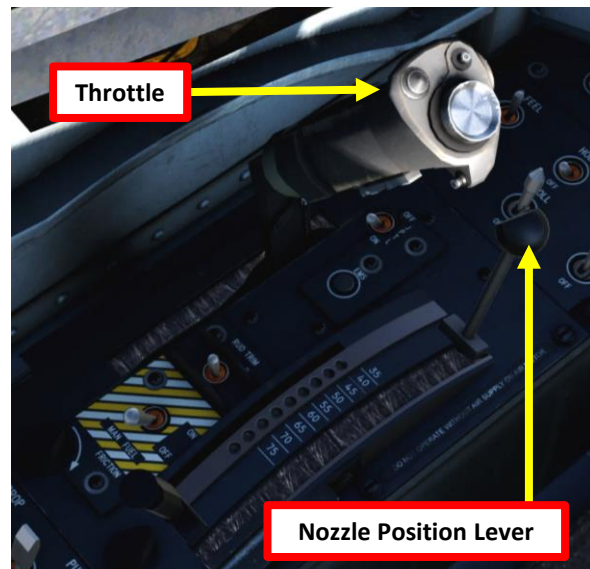

## DRY VS WET THRUST

You will often hear “Dry Thrust” and “Wet Thrust” when reading about the Harrier. Is it related to water? Sort of. Is it related to flying over water? Umm... no.

**Dry thrust** usually refers to « non-augmented” thrust. This means thrust produced without the use of afterburners or liquid injection. The maximum thrust produced by jet engines without afterburner is sometimes called MIL (Military) thrust.

**Wet thrust**, on the other hand, refers to « augmented » thrust. The thrust of a jet engine can be increased by using methods like water/methanol injection (mostly in older turbojet engines) or by using afterburners (reheaters).

Keep in mind that thrust in the Harrier can create a very unstable flight in certain conditions. Consult the pictures to the right and test out the behaviour of the harrier in vertical flight while hovering.

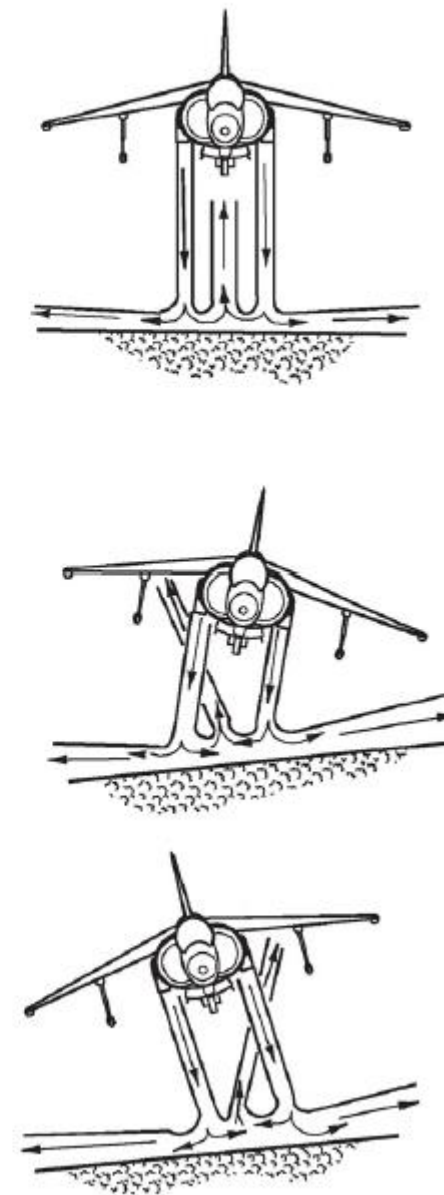
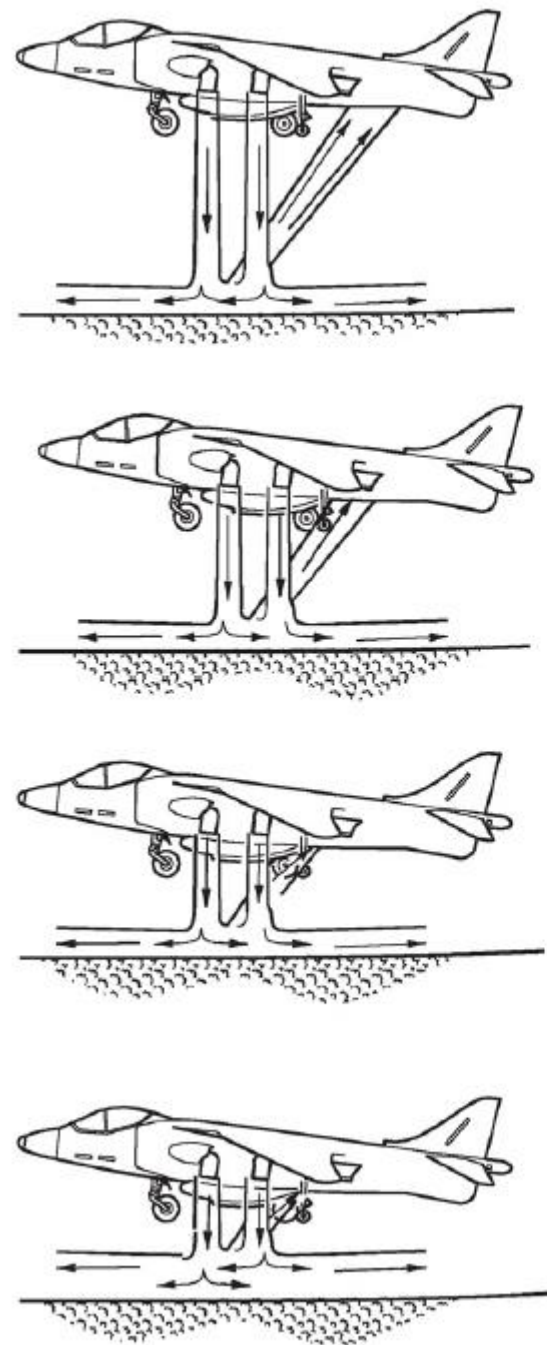
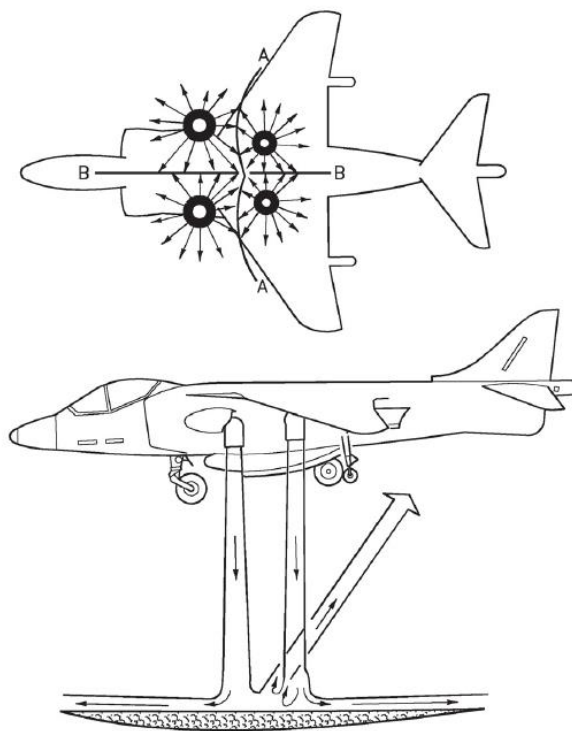

# ENGINE RATINGS & LIMITS

The Pegasus engine of the Harrier requires constant monitoring. The Pegasus is prone to overheating, especially in phases of flight like takeoff and hover.

RPM and JPT (Jet Pipe Temperature) are the primary parameters that you will have to keep an eye on.

If you use the “VSTOL” Master Mode, your engine parameters can be monitored directly on the HUD (Heads-Up Display) with their power margins.

The “**Combat Thrust**” rating can be selected by pressing the CMBT switch/light, which will give you additional thrust. A side-effect of this rating is that your JPT will increase to a point where you can’t use this rating more than a few minutes (about 10 minutes).



CMBT Thrust



VSTOL Master Mode

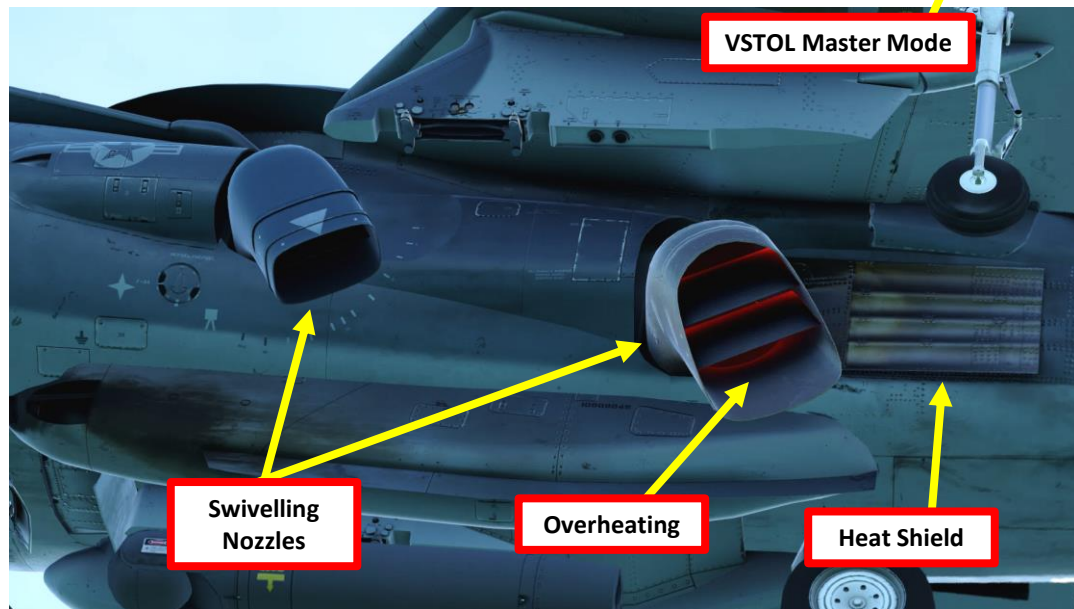

Swivelling Nozzles

Overheating

Heat Shield



Power Margin Indicator (R for RPM, J for JPT)



## Engine Limits

RATING	Notes	LIMITATIONS							
		MAXIMUM % RPM	MAXIMUM °C JPT	COMBINED TIME LIMITS					
SHORT LIFT WET	1	120.0	800	<table border="1"> <tr> <td rowspan="2">A</td> <td rowspan="2">B</td> <td rowspan="2">C</td> <td rowspan="2">D</td> <td rowspan="2">E</td> </tr> <tr> </tr> </table>	A	B	C	D	E
A	B	C	D						
SHORT LIFT DRY		113.5	780						
NORMAL LIFT WET	1, 2	116.0	780						
NORMAL LIFT DRY	2	111.0	765						
COMBAT		111.0	750						
MAXIMUM THRUST		109.0	710						
MAXIMUM CONTINUOUS	2	102.0	645	UNLIMITED					
IDLE	5	28.4 – 29.0	545	UNLIMITED					
STARTING	2, 4		475	MOMENTARILY					

- Do not use water injection below ambient temperatures of -5°C or at altitude above 10,000 feet.
- Requires pilot action to maintain limit.
- Each 2.5 or 10.0 minute period of operation at the lift or combat ratings respectively must be separated by a minimum of 1 minute at maximum thrust or below.
- Slow or abortive starting attempts should be discontinued without waiting for JPT to reach 475°C.
- The minimum allowable sub-idle RPM is 22%

- |    |              |
|----|--------------|
| A. | 15 Seconds   |
| B. | 1.5 Minutes  |
| C. | 2.5 Minutes  |
| D. | 10.0 Minutes |
| E. | 15.0 Minutes |

# ENGINE RATINGS & LIMITS

The Power Margin Indicator indicates the limiting engine parameter, either R (RPM) or J (Jet Pipe Temperature). The Hexagon gradually fills up as JPT/RPM increases. The last leg of the hexagon continues in a straight line and indicates an exceedance: avoid to remain in that engine setting for too long.

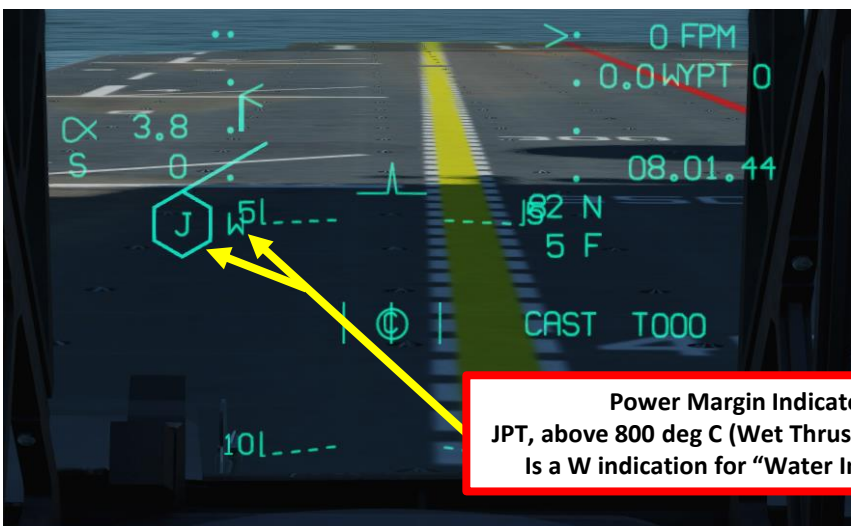
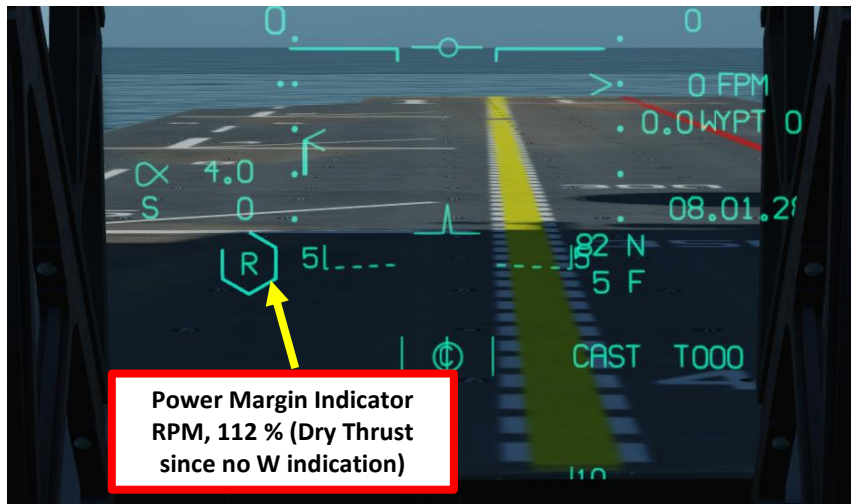

## Power Margin Indicator

	RPM - %			JPT - °C	
	DRY	WET		DRY	WET
R	107.0	113.5	J	715	735
R/	108.0	114.5	J/	725	745
R\	109.0	115.5	J\	735	755
R	110.0	116.5	J	745	765
R/	111.0	117.5	J/	755	775
R\	112.0	118.5	J\	765	785
R	113.0	119.5	J	775	795
R/	113.5	120.0	J/	780	800

# WATER INJECTION

The Harrier uses a Water Injection system. This system injects water in order to cool the JPT (Jet Pipe Temperature) by about 20 deg C. The practical effect of water injection is that it allows the engine to reach higher power settings (i.e. engine RPM by 6 to 7 %) without exceeding JPT limits. Adding water increases the mass being accelerated out of the engine, increasing thrust, but it also serves to cool the turbines.

Keep in mind:

1. Operating the engine within these higher limits can seriously reduce engine life and can cause premature engine failure if overused
2. Water Injection will consume water from the water tank while it is used. When you run out of water, it's gone for good. If you are too heavy and need water injection to land and you have no more water in reserve, you should dump fuel to reduce your weight.
3. Water injection is really used during takeoff and landing. There is no practical use for it in other phases of flight.
4. Do not use water injection below ambient temperatures of 5 deg C, or at altitude above 10,000 ft.
5. Water injection will only be active if the Water Injection Switch is either to TO or LDG, and the engine is in a power setting that exceeds limitations listed on the Engine Limitations page.
6. Water flow is stopped by reducing the throttle below 103 to 105 % RPM or by setting the Water Injection Switch to OFF

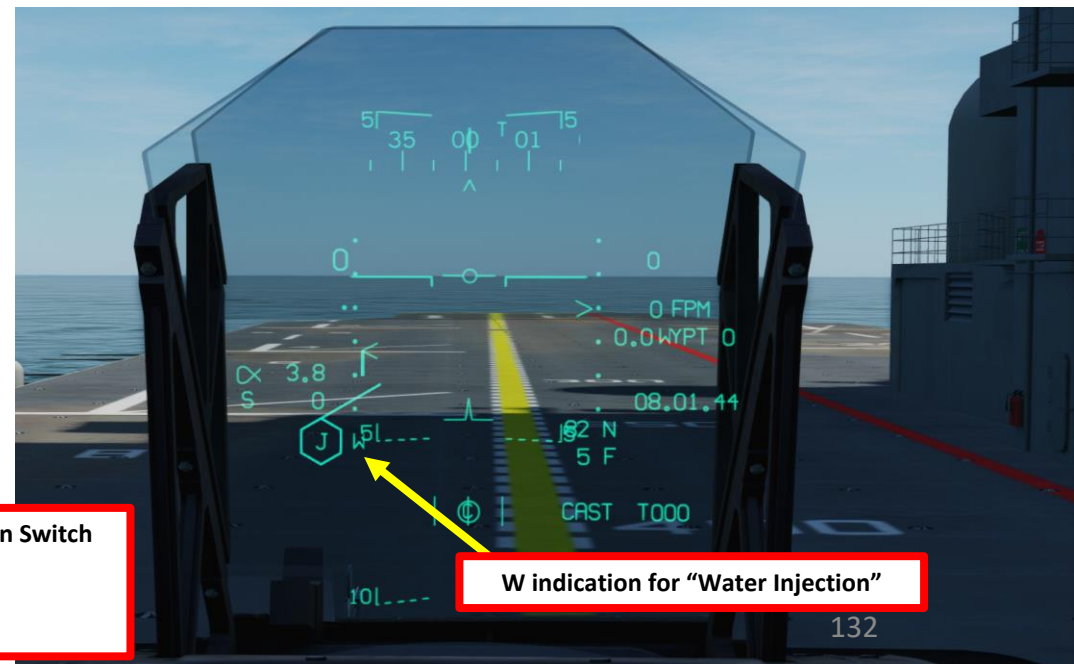
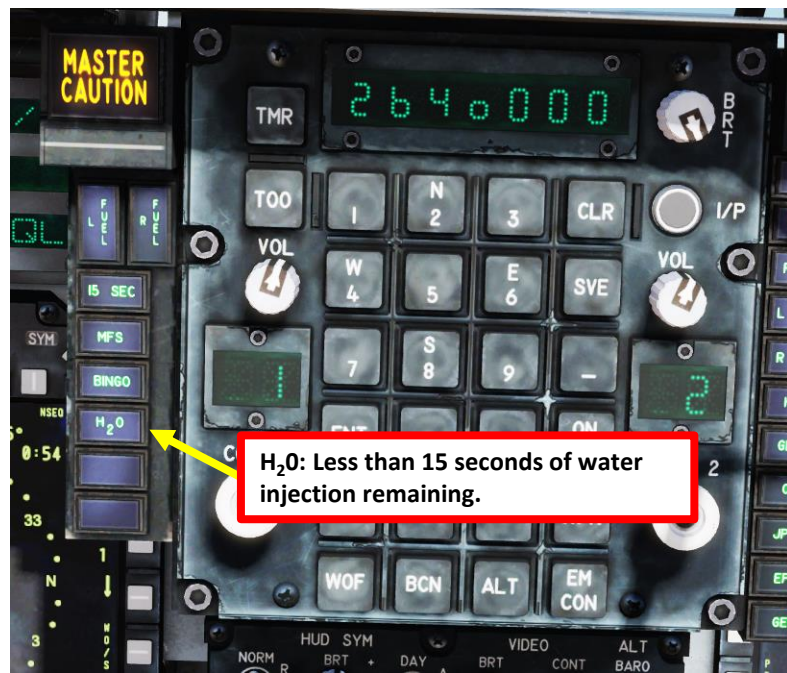
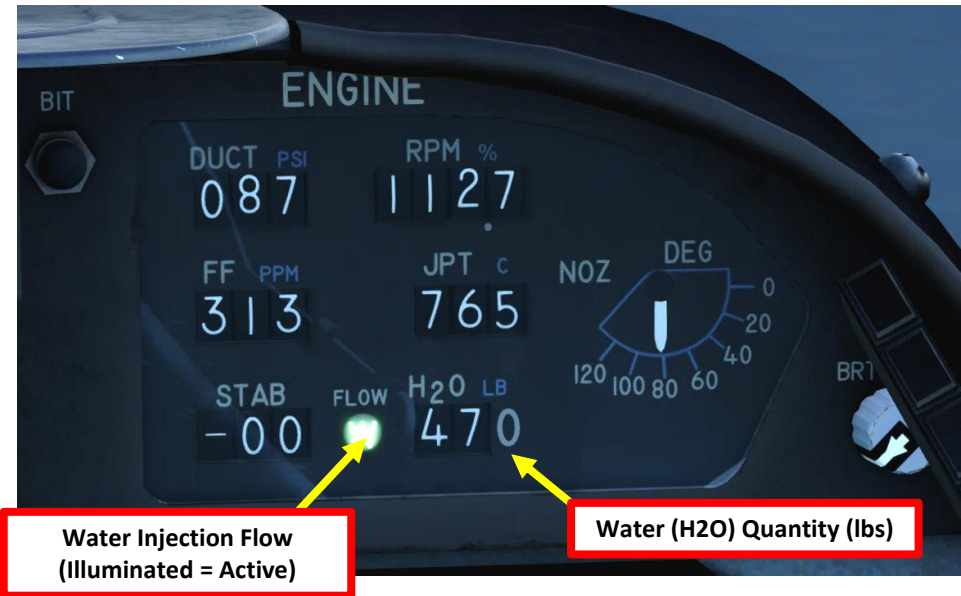

# ENGINE OPERATION TIPS

The Harrier engine can be troublesome for the uninitiated. Here are some tips:

- Hot Gas Ingestion (HGI) is a serious hazard to consider when flying vertically. Avoid doing hover flights and descending too quickly: this can lead hot gas to enter the engine intake and seriously reduce your power, which can be very dangerous when landing or descending.
- Constantly monitor your engine parameters once in a while. The Pegasus CAN break and WILL break if you don't take good care of it.
- Always make mental calculations for your weight. Aircraft weight limitation exceedance is a critical factor when doing a short or vertical landing, and it is one of the main causes for botched vertical landings in DCS.

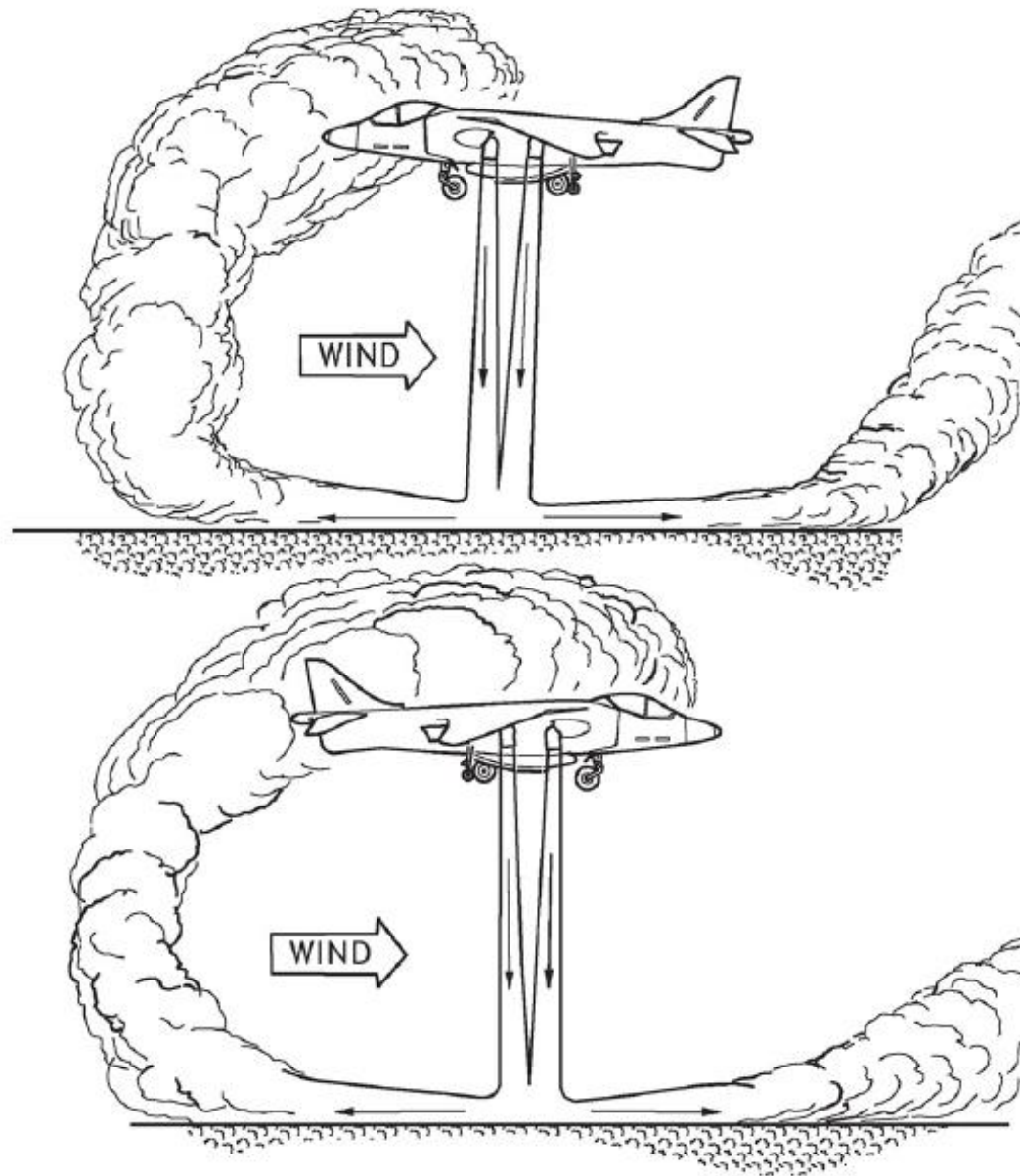
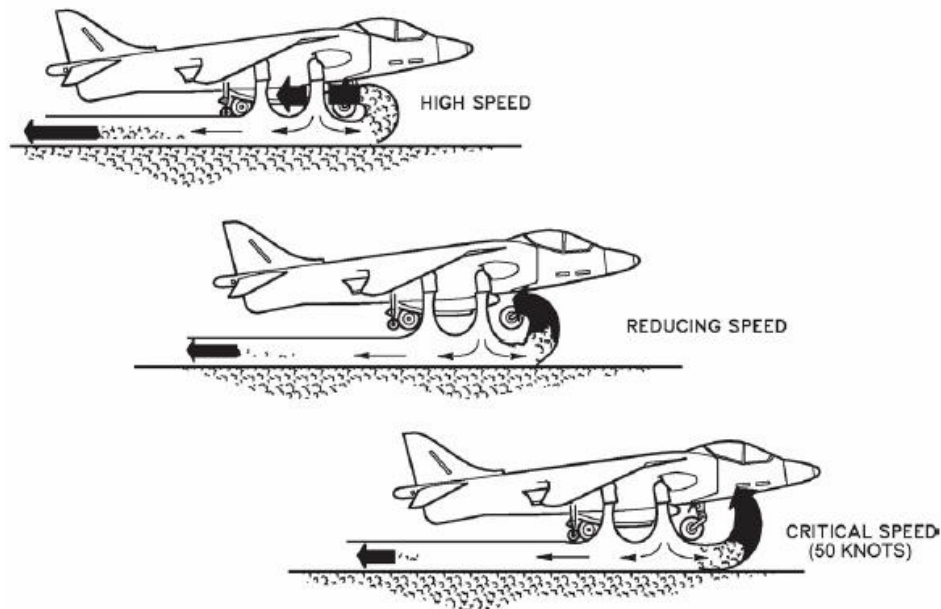

# ENGINE RELIGHT

In case of an engine flameout, you can attempt to restart it by using the engine start procedure listed in the PART 4 – START-UP PROCEDURE section. The airstart envelope includes manual and normal fuel control.

Notes:

- Corrected fan speed is limited to 116.8 % below 10,000 ft MSL and 110.5 % above 30,000 ft.
- When manual fuel is selected, pilot action is required to maintain all engine limits since engine limiters will be overridden by the pilot.
- Maximum engine overspeed is 122 % for 15 seconds or 124 %

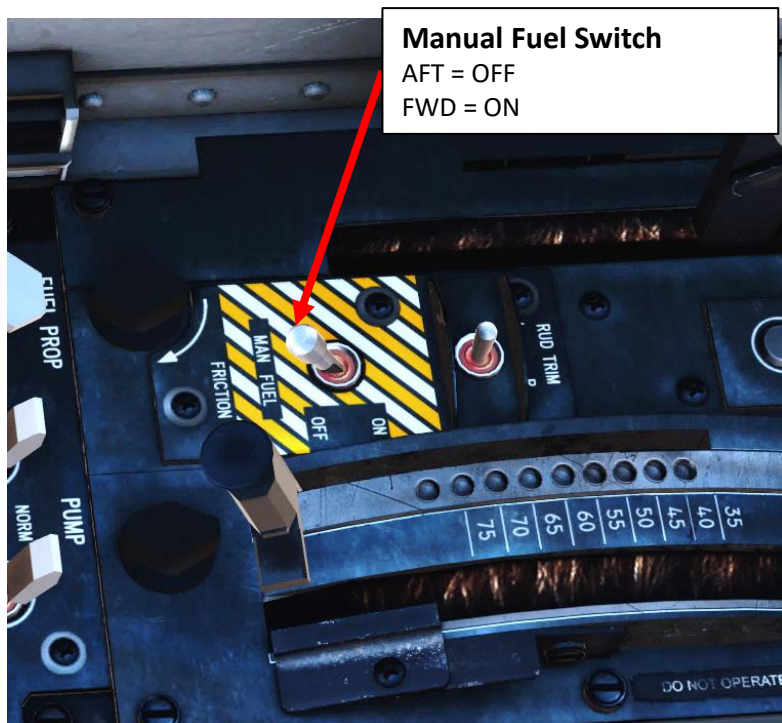

Engine Airstart Envelope

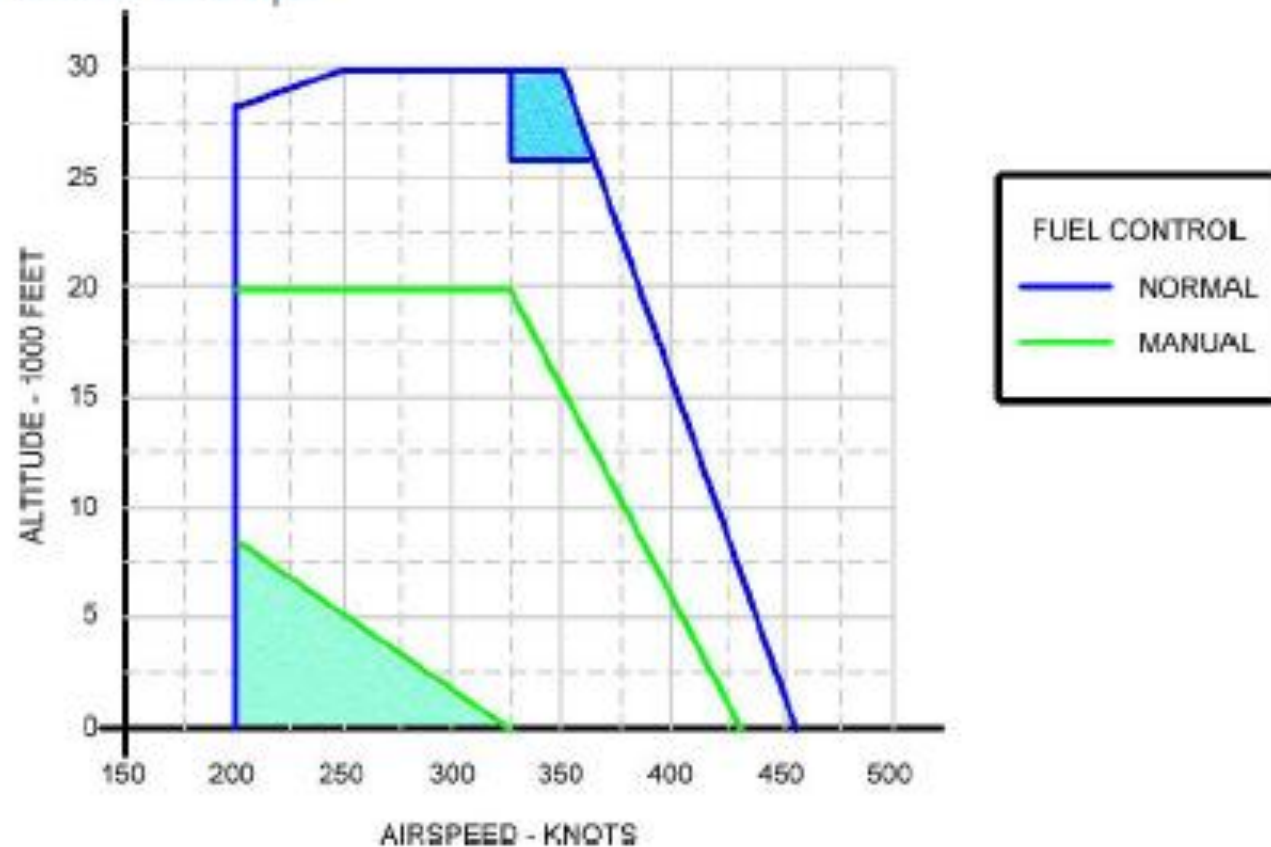

- **Blue Region:** Airstarts attempts in this region may require in excess of 15 seconds for light-off.
- **Green Region:** When the aircraft is in this region, there may not be enough time to relight the engine. Once relight has begun it may require over 30 seconds to reach IDLE rpm.

# LIMITS

## AIRSPEED LIMITATIONS

- Flaps – STOL: 300 kts
- Flaps – CRUISE: 0.87 Mach
- Landing Gear – OPERATION/LOCKED DOWN: 250 kts
- Landing Gear – EMERGENCY EXTENSION: 210 kts
- Q-feel disengaged: 500 kts
- One Hydraulics system inop: 500 kts
- Canopy open: 40 kts
- Wheel in contact with ground: 180 kts ground speed
- LIDS fence extended: 200 kts
- Air Refueling Probe extended: 300 kts

## PROHIBITED MANOEUVERS

1. VTO with asymmetric load/stores greater than 45,000 inch-pounds.
2. STO with asymmetric load/stores greater than 85,000 inch-pounds.
3. CTO with asymmetric load/stores greater than 100,000 inch-pounds.
4. AUTO Flaps SL with asymmetric load/stores greater than 148,000 inch-pounds.
5. STOL Flaps SL with asymmetric load/stores greater than 85,000 inch-pounds.
6. VL with asymmetric load/stores greater than 80,000 inch-pounds.
7. Takeoff with less than 10° nozzles until wingborne.
8. Spin
9. Under 1g for more than 15 seconds.
10. Overriding aileron high speed stop.
11. Roll over 360°.
12. In accelerating or decelerating transition:
  - a. Over 15° AOA above 50 knots with landing gear down.
  - b. Between 30 to 100 knots, slideslip requiring more than ½ lateral stick or with RPS on.
13. Rearward or sideward translation above 30 knots.
14. Thrust Vector Control (TVC) above 30,000 feet at AOA above onset of stall warning/maneuvering
15. Flight above onset of stall warning/maneuvering tone with more than 60,000 inch-pounds asymmetry.
16. Abrupt simultaneous stabilator, rudder or aileron inputs with more than 90,000 inch-pounds asymmetry.
17. Wingborne flight at any speed with more than 148,000 inch-pounds asymmetry.
18. Flight above 0.88 Mach with more than 90,000 inch-pounds asymmetry. (see note)
19. Departure above 250 knots.
20. Rudder deflection above 0.80 Mach.

**Airspeed Limits**

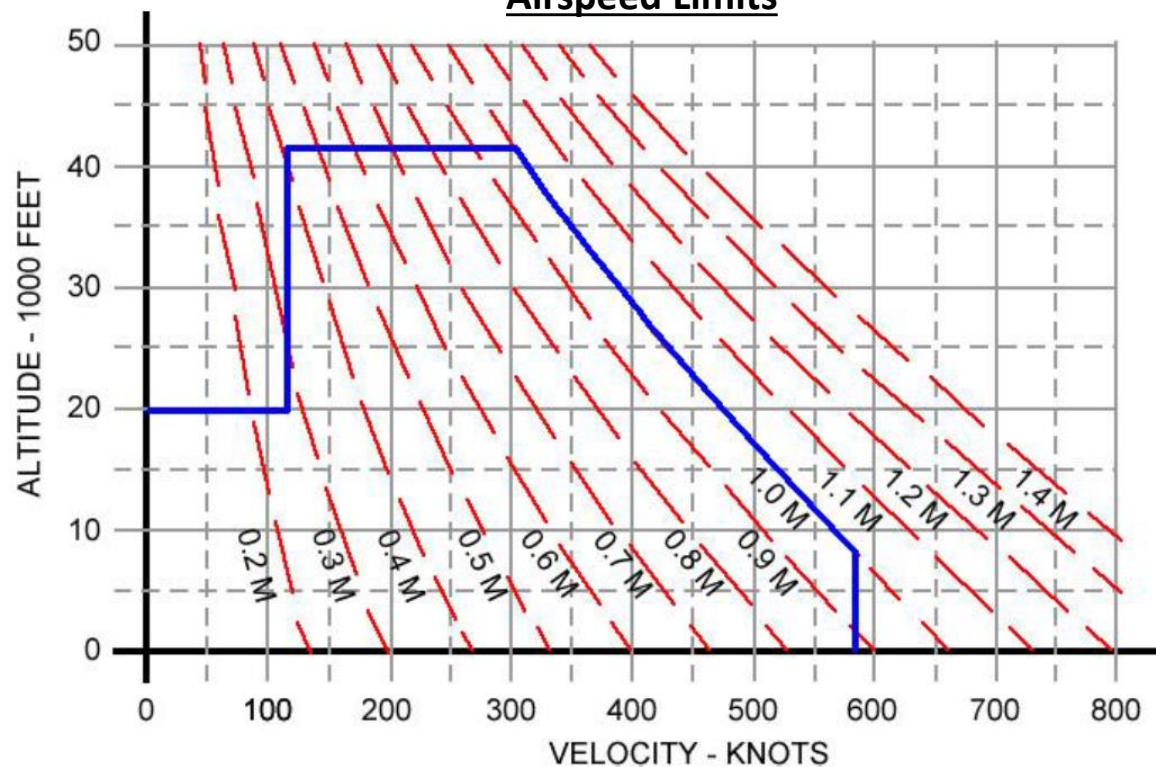

**Angle of Attack Limits**

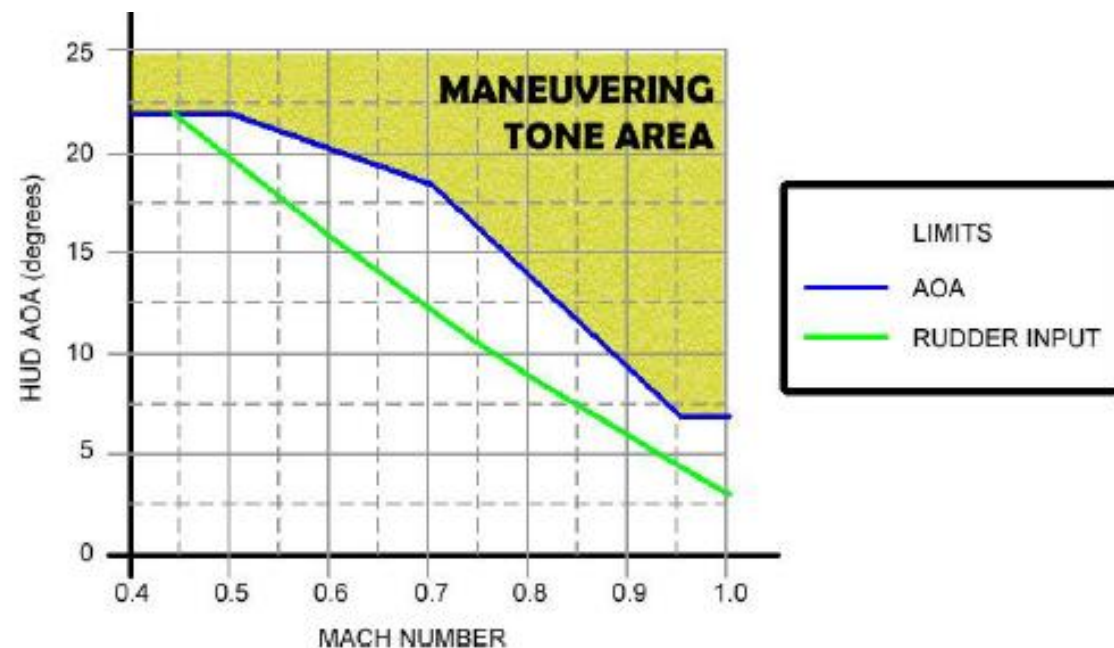

LIMITS

**ACCELERATION LIMITATIONS NOTE**

- Maximum permissible acceleration in the takeoff and landing configuration is 0.0 g to 2.0 g.

**Acceleration Limits (G)  
SYMMETRICAL MANOEUVERS**

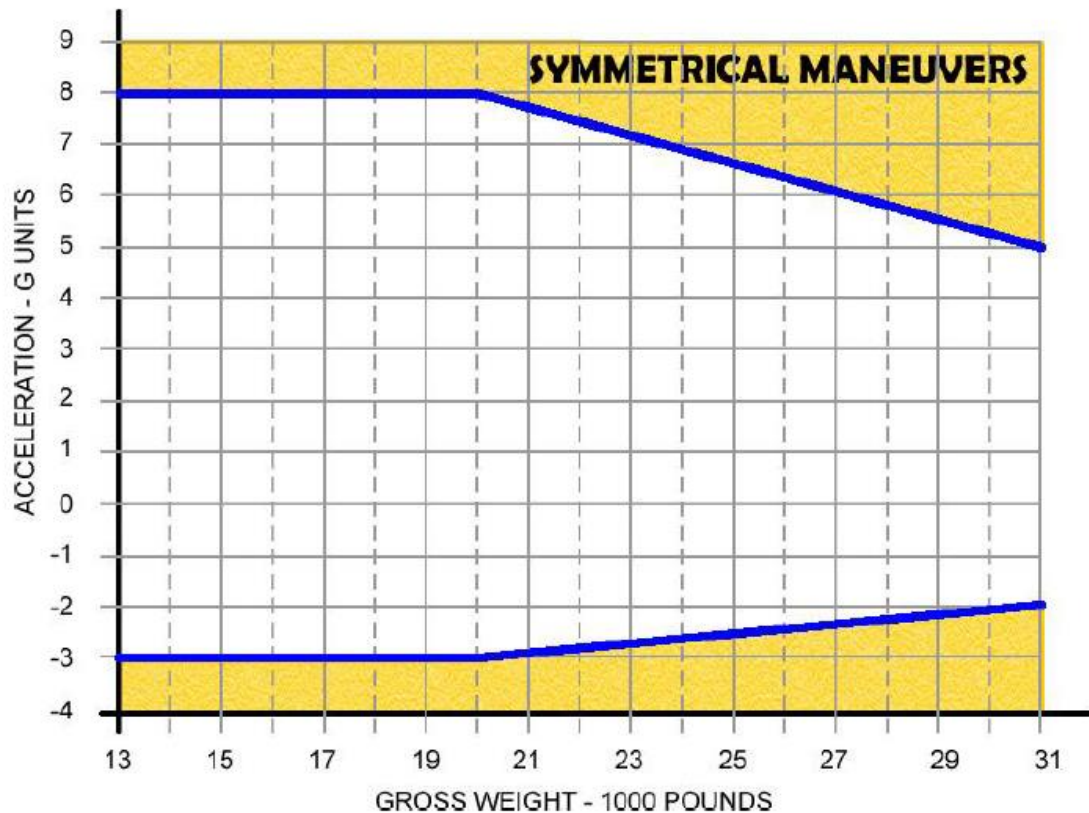

**Acceleration Limits (G)  
ASYMMETRICAL MANOEUVERS**

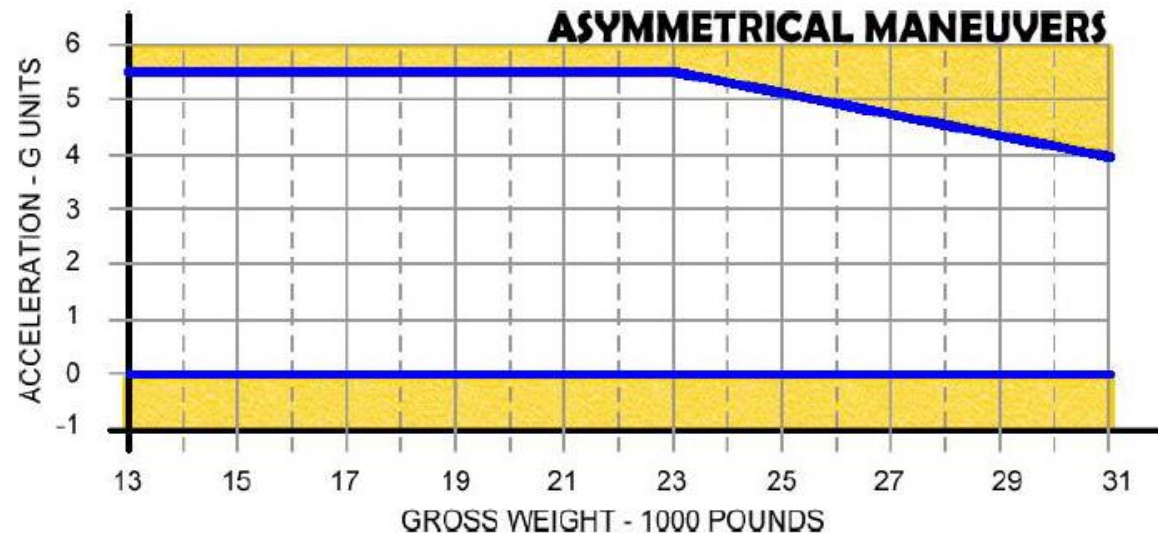

**NOTE**

Air-to-air load is two AIM-9 Sidewinders on pylons 1 and 7 and the GAU-12 gunpod.

## THE VIFF CONCEPT

VIFF (Vectoring In Forward Flight) basically involves pilots rotating the nozzles forward from the usual in-flight horizontal position. In doing so, pilots can quickly deplete their airspeed and bleed energy, causing their surprised pursuer(s) to overshoot, suddenly finding their windscreen devoid of any prey they might have previously been chasing. After dropping altitude as a result of VIFFing, the Harrier can now be free to turn the tables on the predator, making the hunter the hunted. In a turning fight, this is an immense advantage for the Harrier's pilot. But as soon as the pilot VIFFs his opponent, he has to have had a plan for dealing with the bandit, or else he can be in for a world of hurt; that isn't a trick any combat pilot will fall for twice.

On paper, VIFFing sounds like a great idea. However, among VIFF's disadvantages is the fact that it can only really be used effectively in turning fights. If the pursuing aircraft is flying with a wingman, or as part of a larger attack flight, the odds would be stacked fairly high against the Harrier. Additionally, after VIFFing, any other enemy fighters that are not engaged in the melee between the Harrier and the first jet are placed in a prime position to take a shot at the jumpjet, which takes time to rebuild energy from the very-taxing VIFF maneuver (i.e. regain airspeed).



Climb and Flip by Harrier

Defensive Break by Harrier

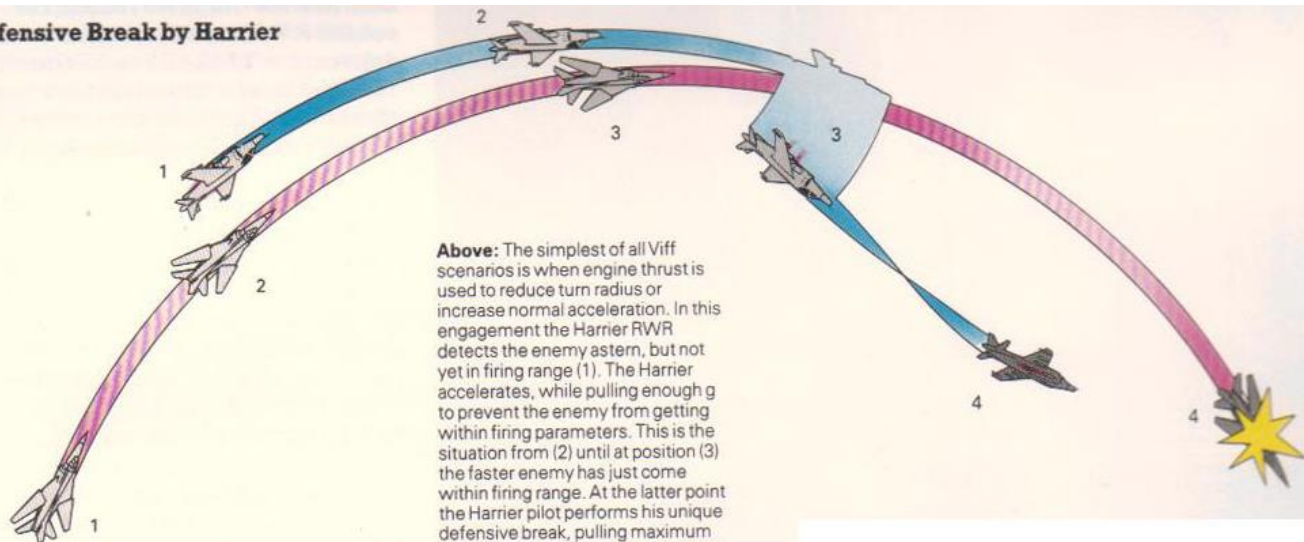

**Above:** The simplest of all Viff scenarios is when engine thrust is used to reduce turn radius or increase normal acceleration. In this engagement the Harrier RWR detects the enemy astern, but not yet in firing range (1). The Harrier accelerates, while pulling enough g to prevent the enemy from getting within firing parameters. This is the situation from (2) until at position (3) the faster enemy has just come within firing range. At the latter point the Harrier pilot performs his unique defensive break, pulling maximum normal acceleration and adding Viff. There is no way the enemy can avoid overshooting, and he then becomes an easy close-range target (4). Variables are numerous, one being that at (3) the Harrier pilot could even set the nozzles to 98-5° for more violent deceleration; another is that at (4) the half-roll may not be necessary, especially if AAMs are used.

**Right:** In these three sets of artwork the Harrier appears as an RAF GR.3, but in fact the drawings are based on originals stemming from the US Marine Corps, who pioneered the use of Viffing as an extra advantage in combat.

**Right:** In this so-called "climb and flip" the Harrier performs one of its numerous "impossible" manoeuvres, which are now part of the routine air-combat repertoire of all experienced US Marine Corps Harrier pilots. The sequence begins with the Harrier (whose trajectory is indicated by a blue line in all these illustrations) and its adversary (red line) climbing in a steep spiral and losing speed, the enemy close behind and eager to get within firing parameters before the Harrier can pull one of its tricks. From this position (1), with the enemy in close trail, the Harrier pilot using light stick forces pulls well past the vertical (2) and, as the speed bleeds away through the 200-knot level, he adds a small nozzle angle (3). The Harrier very quickly flips to a 90° nose-low attitude. The enemy has no option but to follow a semi-ballistic arching curve to end up going steeply downhill. Still travelling quite slowly, the Harrier goes into full reverse (4). There is no way the enemy can avoid going on down past what seems to be a Harrier stopped in mid-air. When the enemy gets to position (5) he presents the simplest possible target, for guns or AAMs.

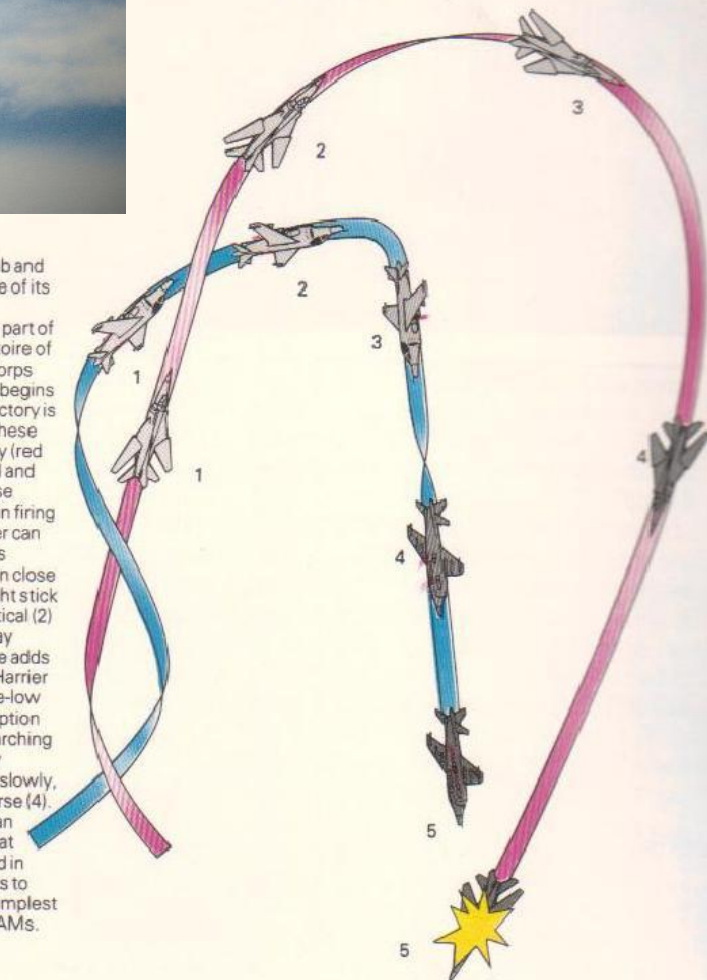

# GPWS: GROUND PROXIMITY WARNING SYSTEM

The GPWS (Ground Proximity Warning System) is a safety backup system that alerts (aural warnings) the aircrew of an impending controlled flight into terrain (CFIT) condition. The GPWS option window 4 on the ODU with **UFC ALT** option selected allows the pilot to disable/enable the system. A colon in the option window indicates selection. GPWS can be deactivated. Deactivation of GPWS starts a 20 minute timer which automatically activates GPWS when the 20 minutes has expired.

GPWS provides warnings of potentially unsafe maneuvering flight conditions, such as excessive bank angles, excessive sink rates, gear—up landings, floor altitude violations, limited protection against flight into rising terrain, diving flight depending on flight stages that include takeoff, cruise, or landing, and Altitude Loss During Recovery (ALDR). GPWS also provides for terrain compensation over downward sloping terrain.

You can also change the Low Altitude Warning Minimum Altitude. To set the LAW altitude just click on the ALT button and any option except PUC. The value in the scratchpad is the selected minimum altitude AGL.



**GPWS: GROUND PROXIMITY WARNING SYSTEM**

VOICE WARNING AND ASSOCIATED WARNING/CAUTION LIGHTS				
VOICE WARNING	PRIORITY NUMBER	WARNING LIGHT	CAUTION LIGHT	IMPLICATION
ENGINE FIRE	1	FIRE	—	Same as warning light.
OVERTEMP	2	OT	—	Same as warning light.
HYDRAULICS	3	HYD	—	Same as warning light.
FUEL CONTROL	4	EFC	—	Same as warning light.
FLAP FAILURE	5	FLAPS	—	Same as warning light.
▷ RIGHT FEED	5	R FEED	—	Same as warning light.
LANDING GEAR	6	GEAR	—	Same as flashing GEAR warning light.
ALTITUDE	7	LAW	—	Same as warning light.
LEFT TANK	8	LTANK	—	Same as warning light.
RIGHT TANK	8	RTANK	—	Same as warning light.
FIFTEEN SECONDS	9	—	15 SEC	Same as caution light.
BINGO	10	—	BINGO	Same as caution light.
LIMITER OFF	11	JPTL	—	Same as warning light.
OBSTACLE	12	—	—	Aircraft is at or below the set obstacle clearance elevation angle for AWLS.
WATER	13	—	H <sub>2</sub> O	Same as caution light.
FUEL LOW, LEFT	14	—	L FUEL	Same as flashing caution light.
FUEL LOW, RIGHT	14	—	R FUEL	Same as flashing caution light.
GENERATOR	15	GEN	—	Same as warning light.
MANUAL FUEL	16	—	MFS	Same as caution light.
CAUTION	17	—	MASTER CAUTION	A caution light on the caution/advisory light panel has illuminated.
ACNIP GO	—	—	—	ACNIP BIT passed.
ACNIP FAIL	—	—	—	ACNIP BIT passed.

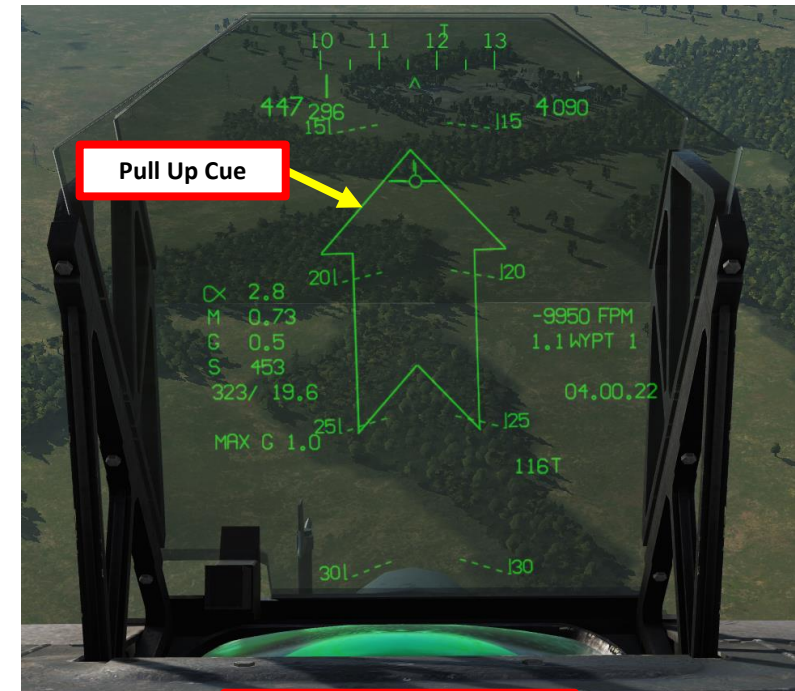

## INTRODUCTION

The Harrier comes equipped with the following sensors:

- **INS** (Inertial Navigation System): the built-in INS can be used for target designation with coordinate position (waypoint, mark points, mark offset points) and other parameters (inertial velocities, line of sight angles, etc.) to determine weapon release solution.
- **ARBS** (Hughes Angle Rate Bombing System): Built-in passive system designed to improve day and night bombing accuracy when operating in the close support role using unguided weapons
  - **DMT** (Dual Mode Tracker): Sub-system of the ARBS, the DMT tracks both TV (reflected light images) and laser-designated (LST) targets.
- **NAVFLIR** (Navigation Forward-Looking Infrared): Built-in FLIR system fixed on the aircraft's waterline, which is mainly used for navigation and target infrared spotting. It does NOT have any target designation capability.
- **AN/AAQ-28V Litening II Targeting Pod (TPOD)**: Targeting system developed to provide precision strike capability. Target designation is achieved by using a laser designator/range finder or an infrared laser marker, which can be created by the pod itself. It is also capable of displaying a FLIR thermal imagery.
- **AMG-65F Maverick Seeker Head feed**: Maverick air-to-ground missiles have seeker heads that have video capability and that can be used as supplemental sensors.

Now... why would the Harrier need all these sensors? It seems a bit overkill, no? Well, not really. Each sensor is useful in specific cases with specific weaponry for specific missions. The Harrier being operated by the United States Marine Corps, mission versatility is one of the main reasons this aircraft was so relevant to the types of operations conducted by the USMC.



# INTRODUCTION

The sensors will make more sense to you once you start using them in the Weapons Tutorial section.

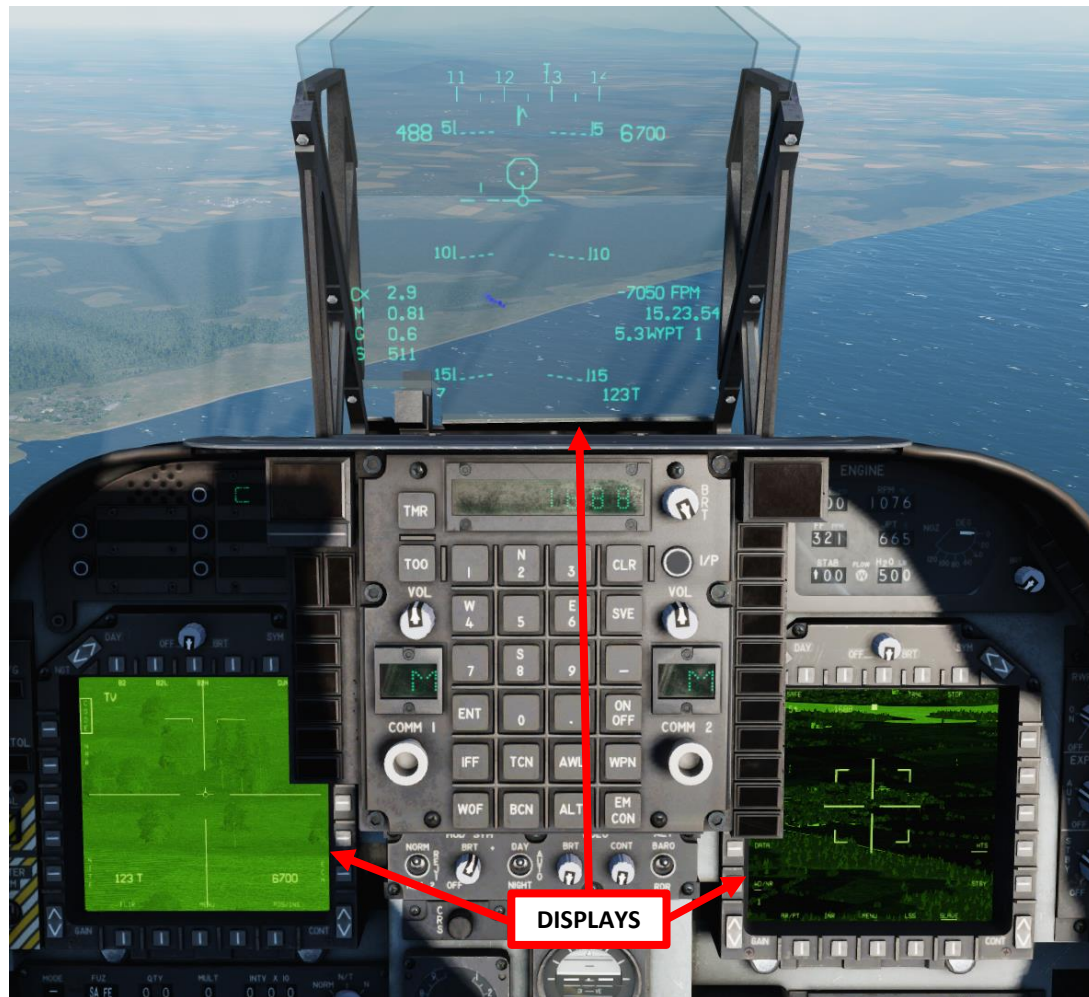

**DISPLAYS**



**Sensor Select Switch**  
 AFT = DMT: LST/TV  
 FWD = INS: IRMV/EOMV  
 LEFT = MAP Center/Decenter  
 RIGHT = FLIR/HUD-BH/WH  
 DOWN (PUSHED) = HUD Scene Reject/TPOD



**TDC (Target Designation Caret) Control Switch**  
 LEFT/RIGHT/FORWARD/AFT/DOWN (ACTION)



**SCREEN**

**CONTROLLER**

# MY SENSORS CONTROL SETUP

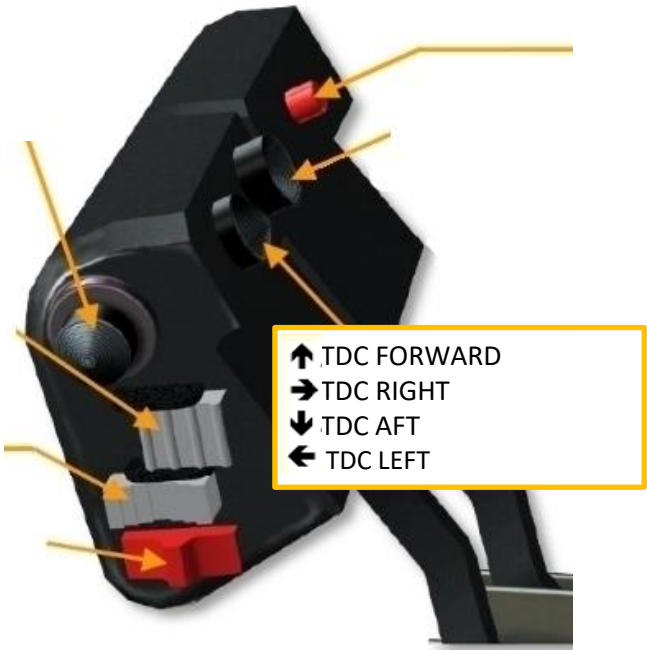
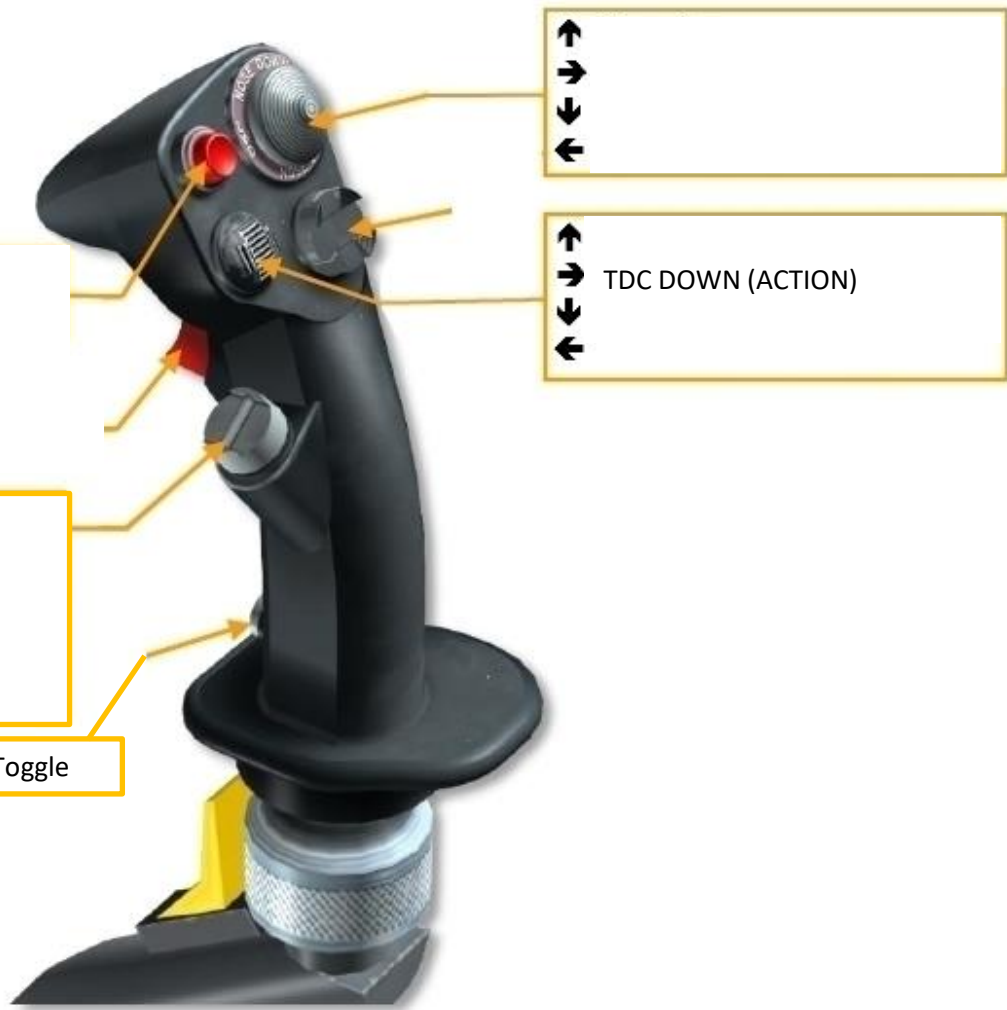

# NAVFLIR

1. NAVFLIR is powered by the FLIR switch (UP). The FLIR requires a cooldown time of approx. 5 minutes: NOT RDY legend on either MPCD will be shown as long as cooldown process is not complete.
2. You can consult the FLIR page on either MPCD by going in the main menu and pressing the OSB next to FLIR.
3. You can toggle BLACK/WHITE (BLK) modes using the BLK option.
4. During night operations, you can display the FLIR feed on your Heads-Up Display directly.
  - a) Set HUD Mode switch to NIGHT (down position)
  - b) Press the « Sensor Select » switch DOWN (HUD Scene Reject)

### Sensor Select Switch

- AFT = DMT: LST/TV
- FWD = INS: IRMV/EOMV
- LEFT = MAP Center/Decenter
- RIGHT = FLIR/HUD-BH/WH
- DOWN (PUSHED) = HUD Scene Reject/TPOD

4b

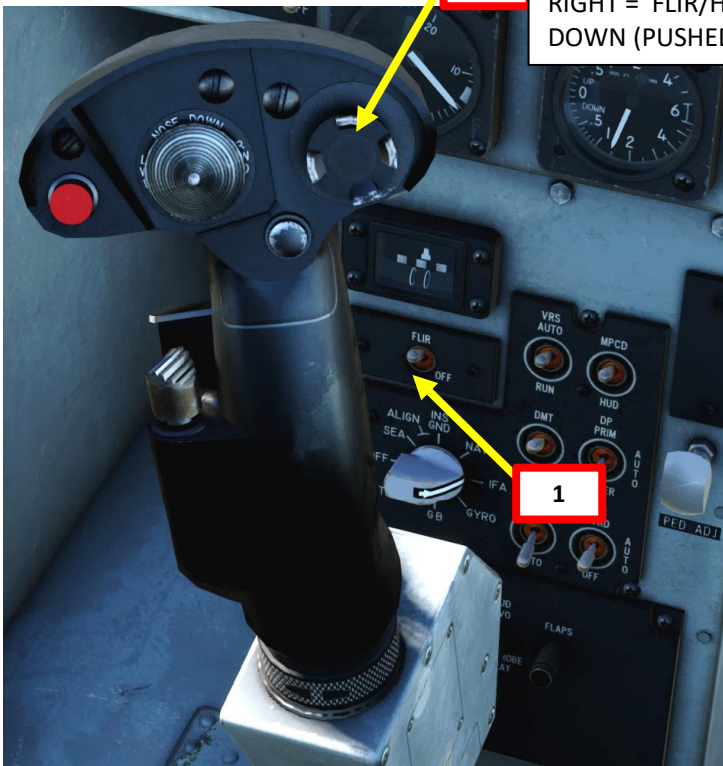

1

4a



3

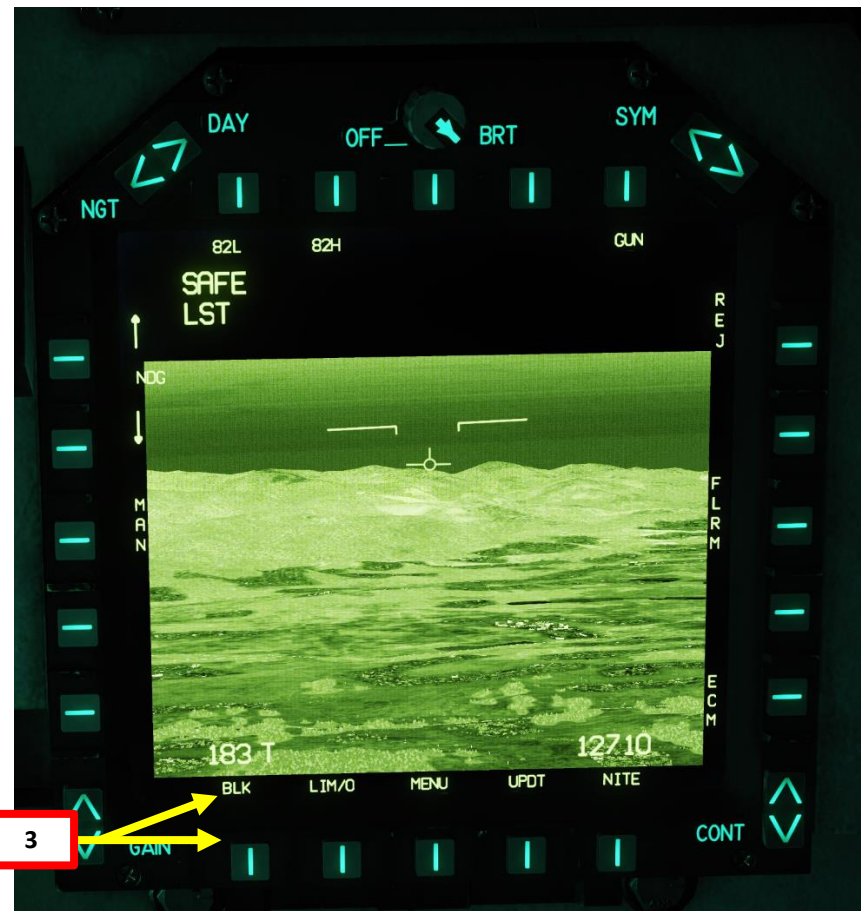

NAVFLIR



4c

## ARBS & DMT IN A NUTSHELL

The ARBS's Dual Mode Tracker (DMT) has two main functions: TV and LST (Laser).

The TV function will allow you to set manually a target point by pointing your nose at the target and then designating it. Then, the DMT is able to keep track of this position.

The LST (Laser) function will allow you to slave your DMT to a laser-designated point by troops on the ground or friendly aircraft equipped with a laser designator (which can be done with the TGP).



ARBS Glazed Aperture

### DMT: TV MODE



### DMT: LASER MODE

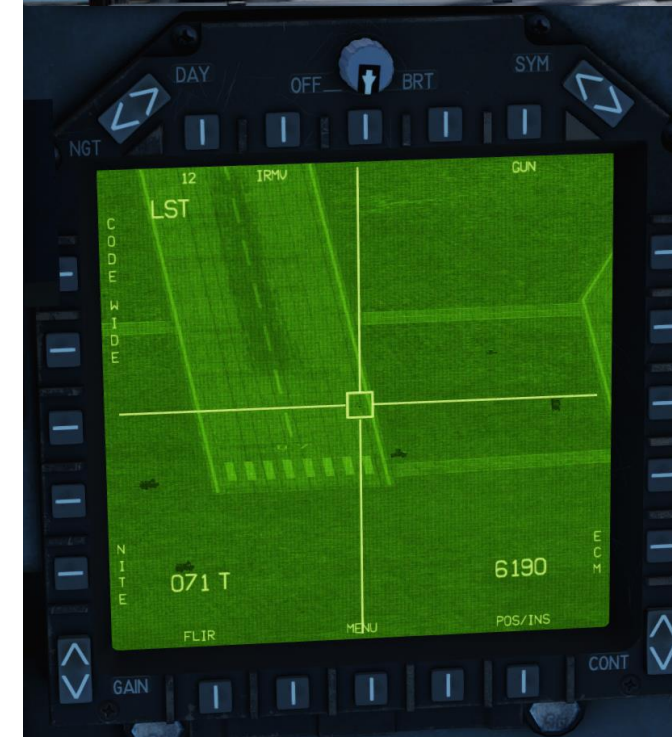

# ARBS & DMT – TV MODE

1. The DMT Power Switch powers up the Dual Mode Tracker.
2. Press the Sensor Select Switch AFT to toggle LST/TV Mode of the DMT to TV. DMT feed will appear on your MPCD displays.
3. At first, TV Mode tracks your aircraft's flight path vector (where your nose is pointing).
4. Press the « TDC DOWN Action Position » button to slave the DMT to a designated target.
5. Once target is designated, you can slew the DMT
6. Press the « AG Target Undesignate/NWS/FOV Toggle » to un-designate a target.

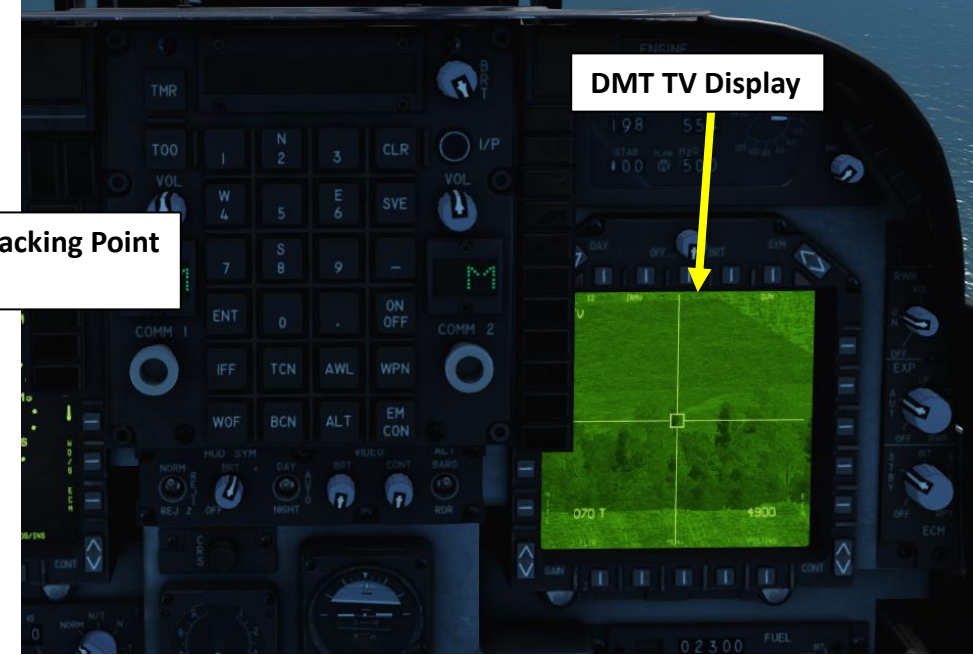
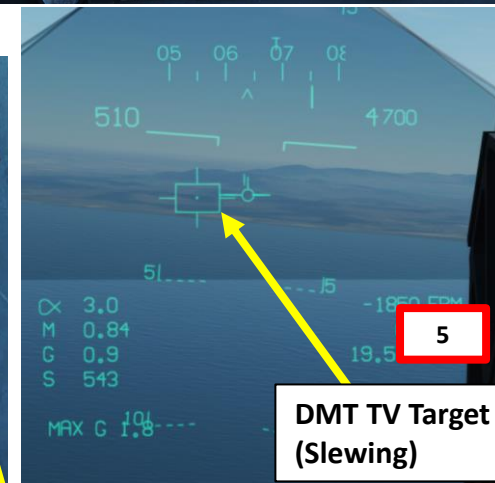
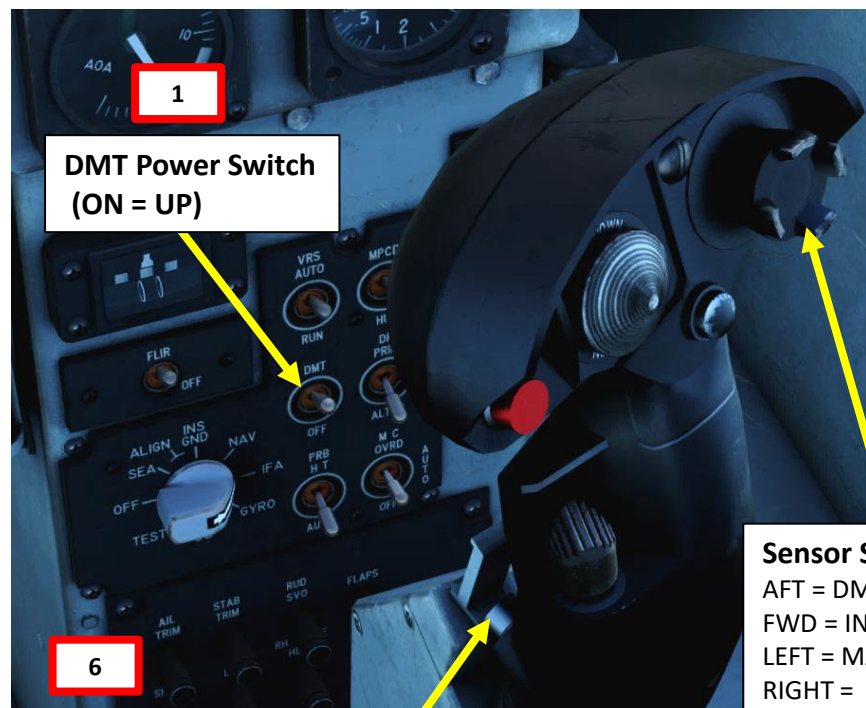
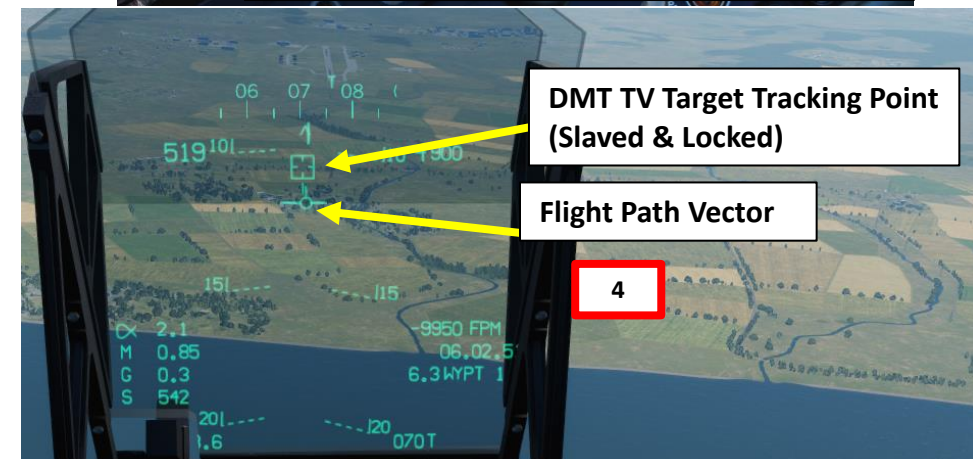
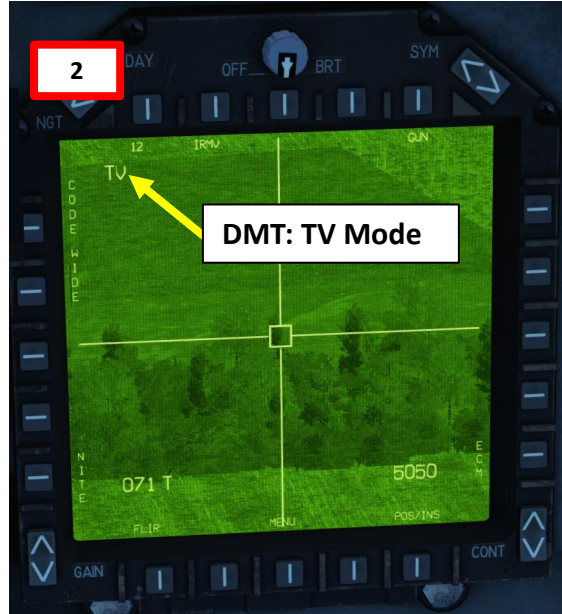

**Sensor Select Switch**  
 AFT = DMT: LST/TV  
 FWD = INS: IRMV/EOMV  
 LEFT = MAP Center/Decenter  
 RIGHT = FLIR/HUD-BH/WH  
 DOWN (PUSHED) = HUD Scene Reject/TPOD

**6**

AG Target Undesignate/NWS/FOV Toggle Switch

# ARBS & DMT – LST MODE

1. The DMT Power Switch powers up the Dual Mode Tracker.
2. Press the Sensor Select Switch AFT to toggle LST/TV Mode of the DMT to LST (Laser). DMT feed will not yet appear on your MPCD displays if no laser is within range (SAFE LST).
3. Press the OSB (Option Select Button) next to CODE, then set required laser code on the keypad (1688 by default), then press ENT.
4. At first, LST Mode tracks your aircraft's flight path vector (where your nose is pointing).
5. Once you have contacted the JTAC (Joint Terminal Attack Controller) and a friendly unit is lasing a target (LASER ON), fly towards the target and set your DMT Laser Tracking Point in the target area.
6. Laser will automatically be locked on once you are within range of laser, designating the target.
7. Press the « AG Target Undesignate/NWS/FOV Toggle » to un-designate a target.

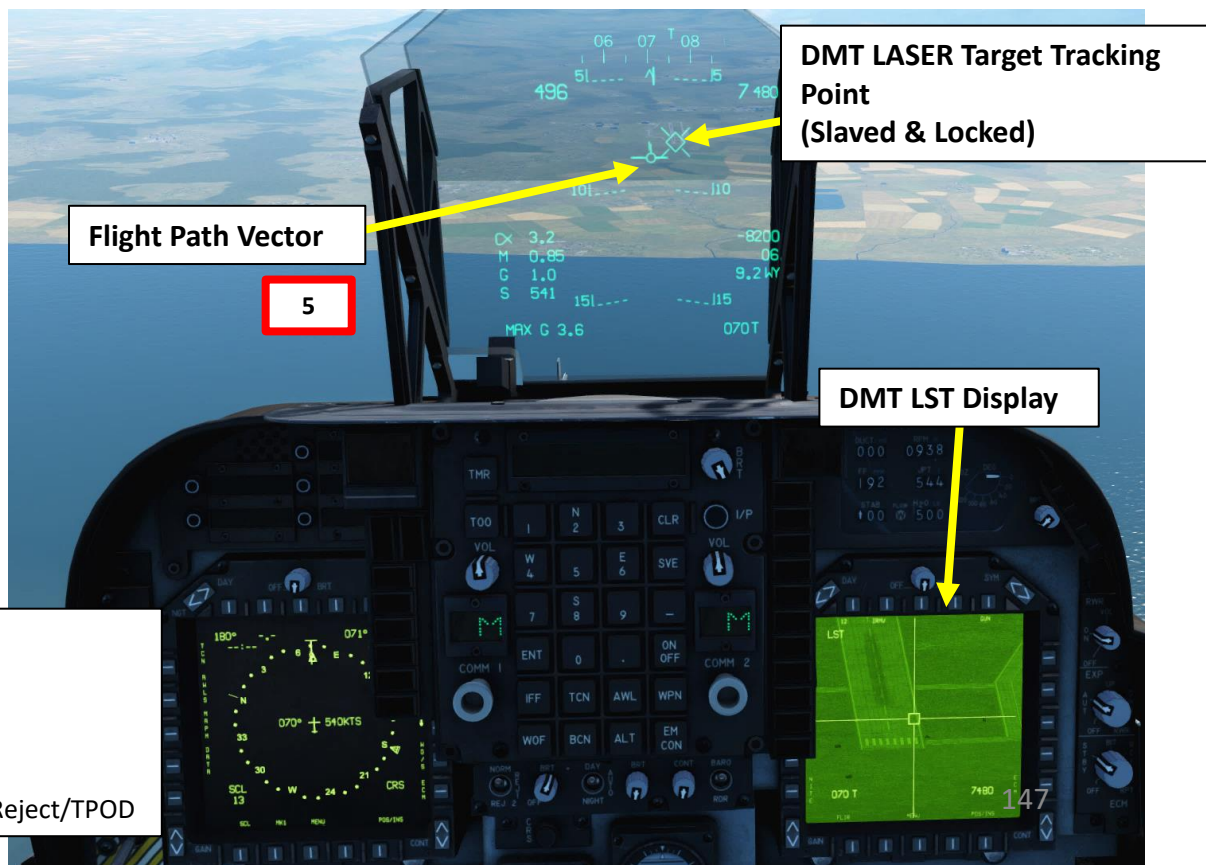
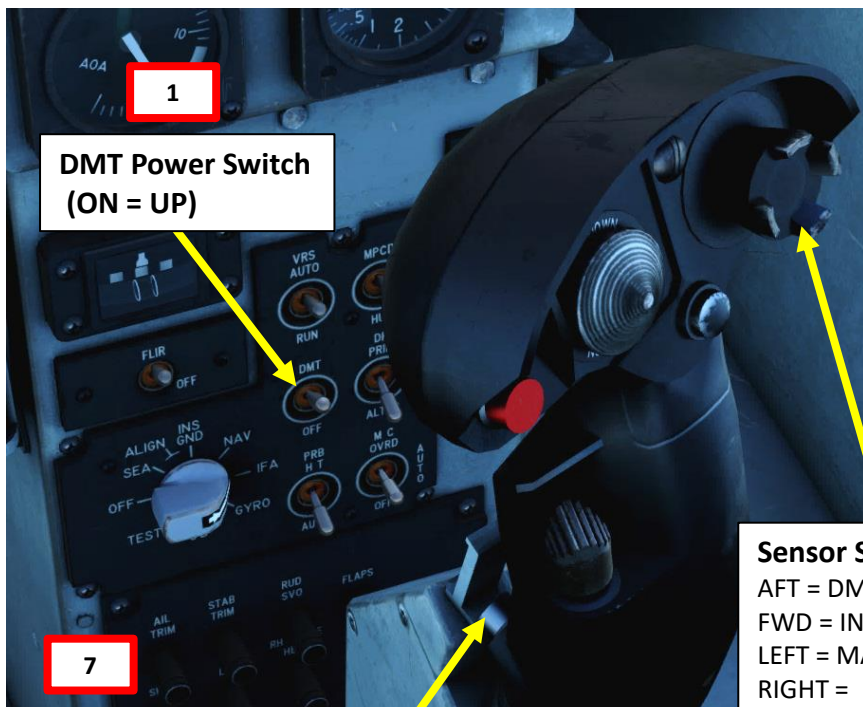
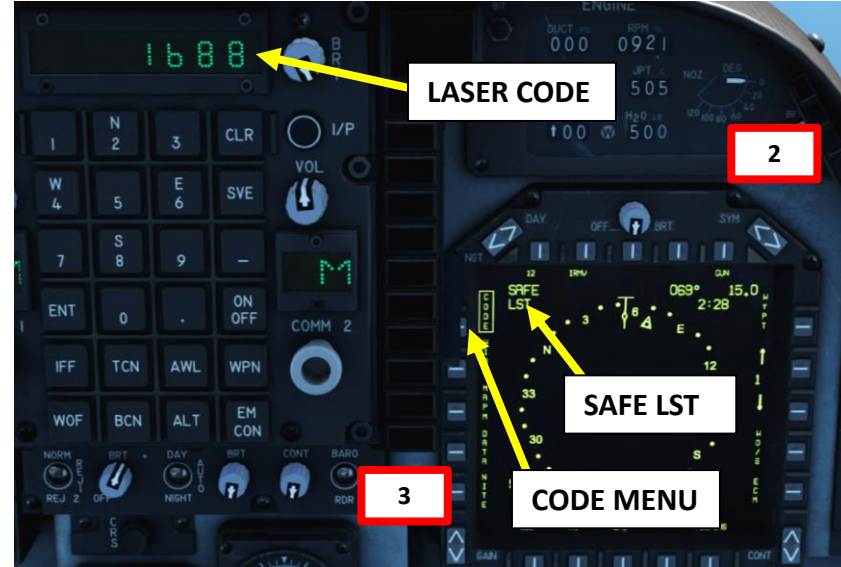
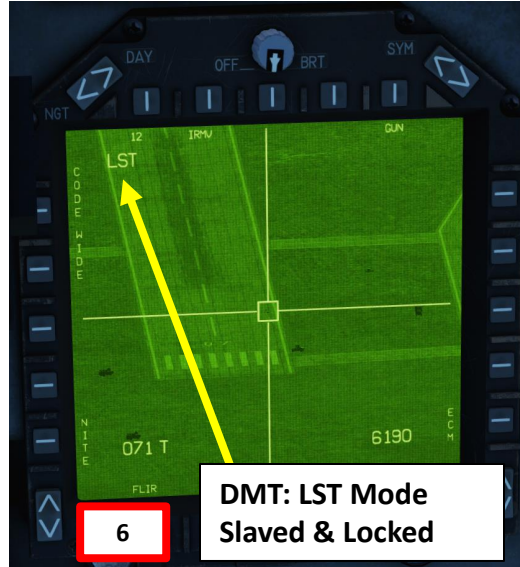

**Sensor Select Switch**  
 AFT = DMT: LST/TV  
 FWD = INS: IRMV/EOMV  
 LEFT = MAP Center/Decenter  
 RIGHT = FLIR/HUD-BH/WH  
 DOWN (PUSHED) = HUD Scene Reject/TPOD

**AG Target Undesignate/NWS/FOV Toggle Switch**

# AN/AAQ-28 LITENING II TARGETING POD

The TPOD (Targeting Pod) is used as an alternate sensor to the DMT (Dual Mode Tracker). It provides more options to properly monitor a target area.

1. The Targeting Pod can be powered up by:
  - a) Clicking on the OSB next to the "TPOD" page in the main MPCD MENU
  - b) Clicking the OSB next to STBY
  - c) The Targeting Pod will start its initialization for 3 minutes.
  - d) After initialization, the pod starts FLIR cooling, which takes approximately 6 to 8 minutes. Pod will display F-NOTRDY (FLIR Not Ready) indication when FLIR cooling is incomplete.

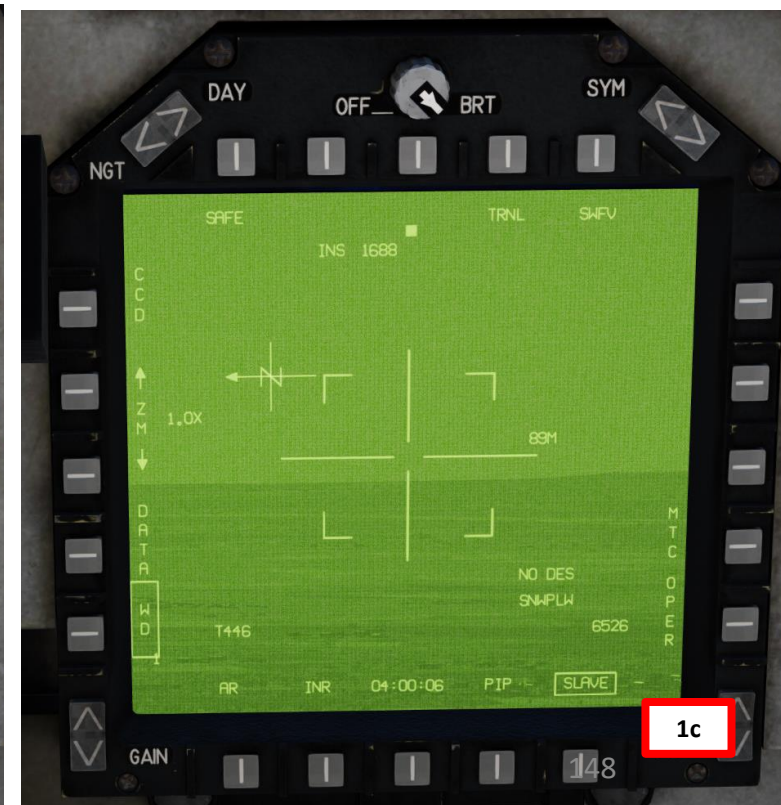
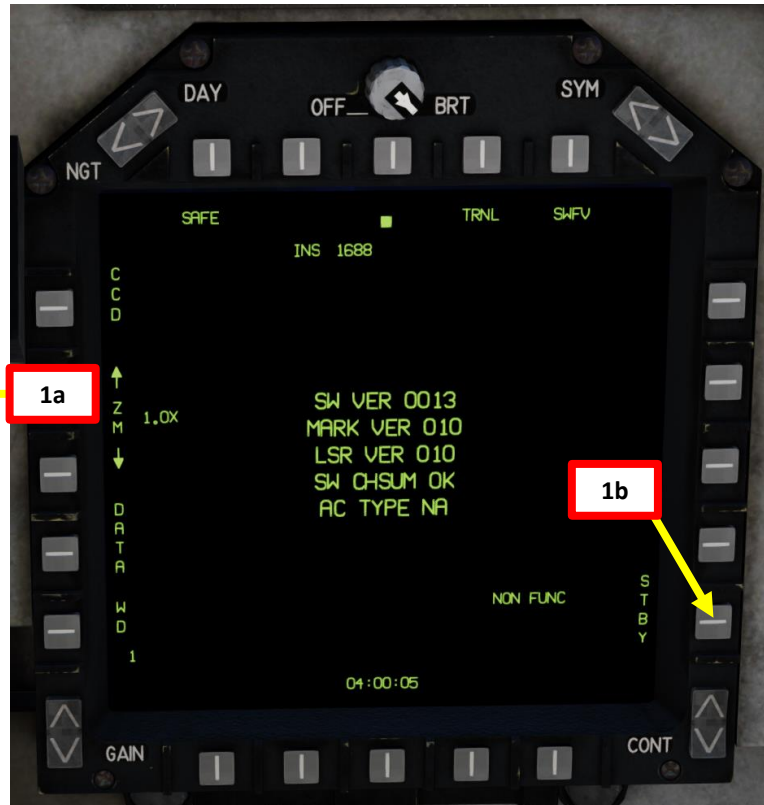
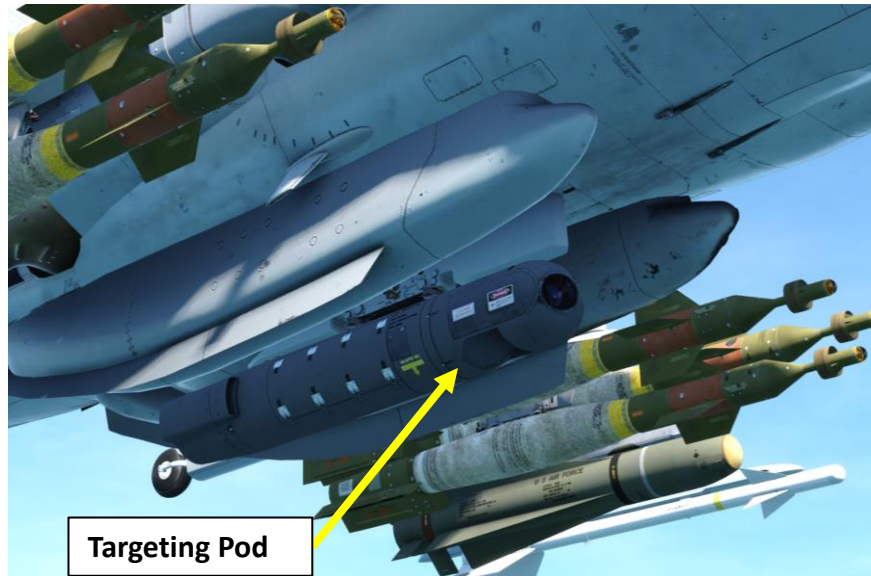

# AN/AAQ-28 LITENING II TARGETING POD

- In order to use the TDC (Target Designation Caret), press the Sensor Select Switch DOWN twice to use TPOD Mode.
- You can slew your TDC using the TDC LEFT/RIGHT/FWD/AFT controls.
- Press the « TDC DOWN Action Position » button to designate a target.
- Select desired Laser Mode, Laser Options, Arm Laser
- Fire Laser
- Press the « AG Target Undesignate/NWS/FOV Toggle » to un-designate a target.

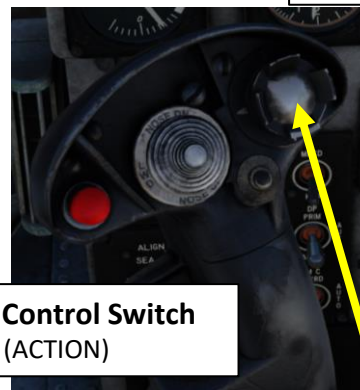

TDC (Target Designation Caret) (Slaved)

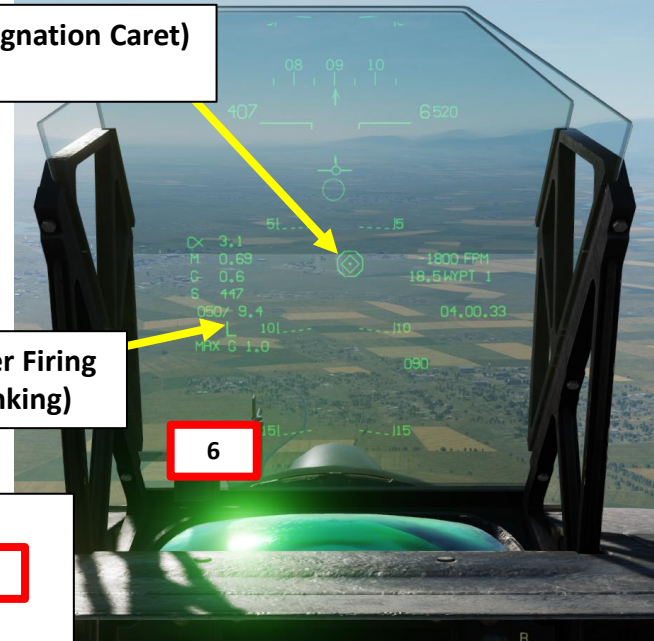

Laser Firing (Blinking)

TDC (Target Designation Caret) Control Switch  
LEFT/RIGHT/FORWARD/AFT/DOWN (ACTION)

5a Laser Mode (Training/Marker/Laser)

6 Laser Firing Button

SWFV (Super-Wide Field of View)

Sensor Select Switch  
AFT = DMT: LST/TV  
FWD = INS: IRMV/EOMV  
LEFT = MAP Center/Decenter  
RIGHT = FLIR/HUD-BH/WH  
DOWN (PUSHED) = HUD Scene Reject/TPOD

2a

5b Laser Options (Armed/Safe)

TPOD FLIR Black/White Hot

CCD (Charged-Coupled Device, or TV)/FLIR Mode

2b

Laser Code

TDC (Target Designation Caret) (Slaved)

6

Zoom +/- Buttons

TPOD Data Page

Wide/Narrow Field of View

TDC (Target Designation Caret) (Slaved & Locked)

TPOD Mode

Area Track/Point Track Mode

Hold INR Button to activate LSS/LST (Laser Spot Search/Laser Spot Track) Mode

Laser Firing (Blinking)

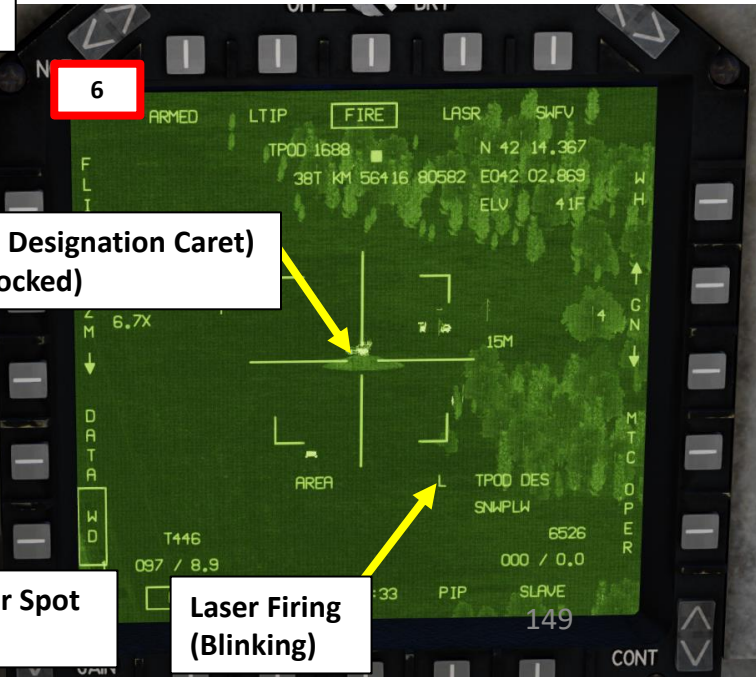
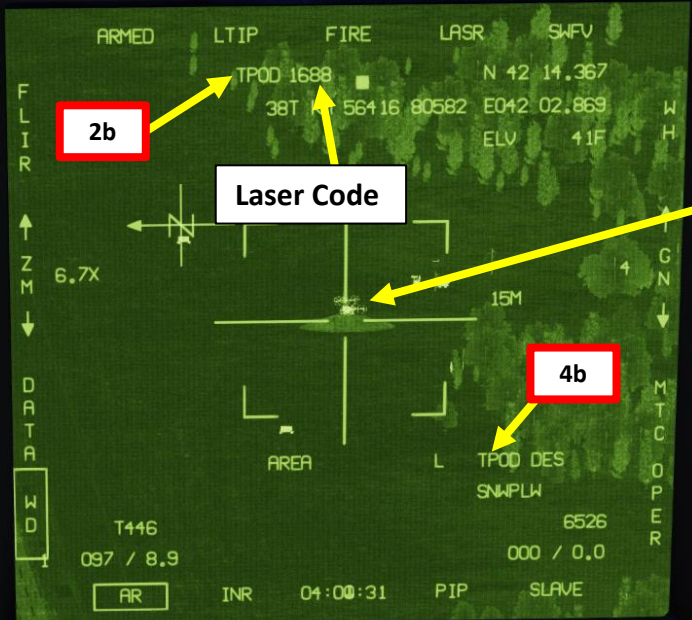

# AN/AAQ-28 LITENING II TARGETING POD

The Targeting Pod View Relative Direction symbol on the FLIR display can give you a good idea of where the pod is pointing in relationship to your aircraft. This view direction is represented in a top-down view.



Targeting Pod is looking here

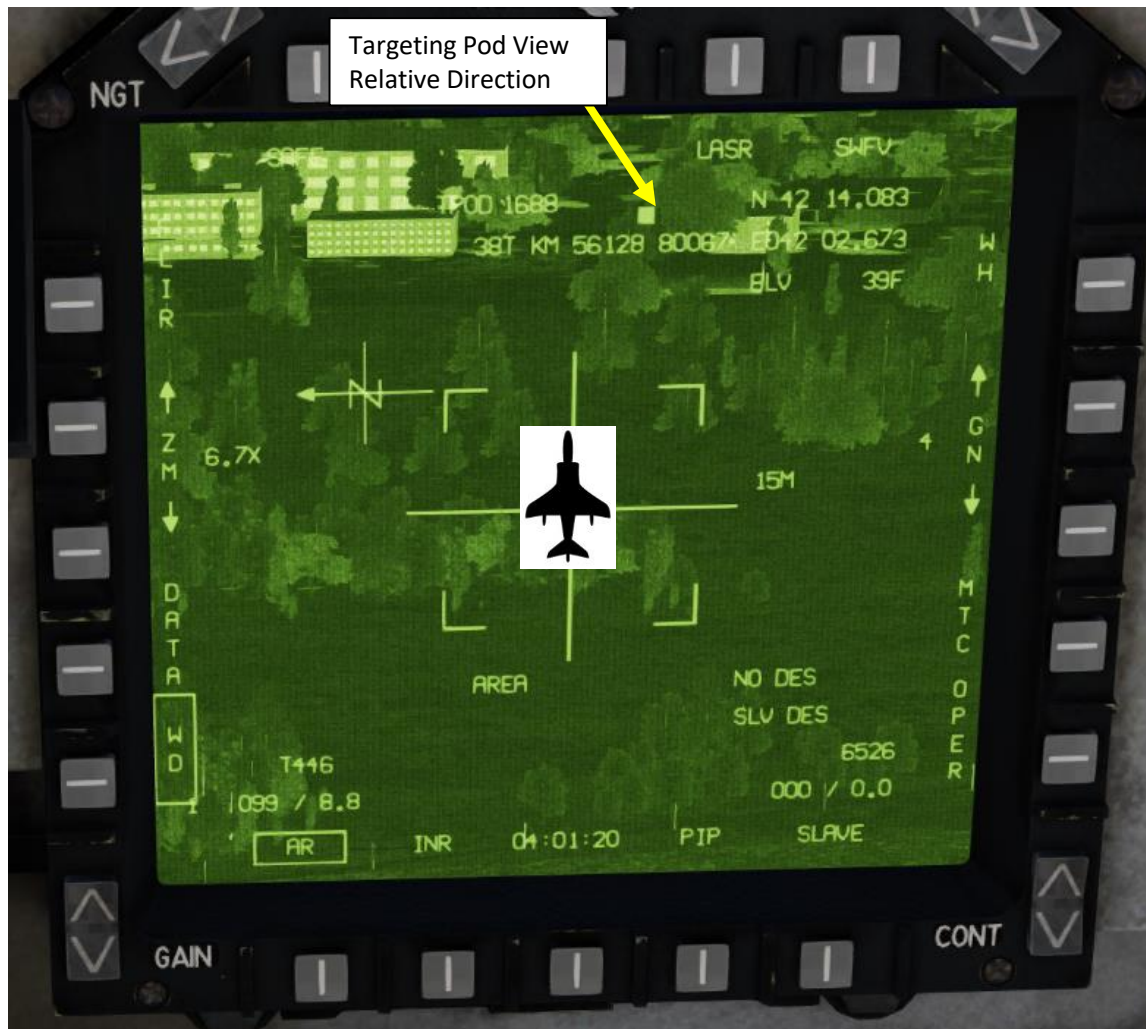

Targeting Pod View Relative Direction

# LASER CODES

1. Each time the aircraft is on the ground (Weight on Wheels ON), the Laser Code resets to 1111 automatically.
2. Press A/G (Air-to-Ground) Master Mode Button
3. Go in EHSD page, then click OSB next to CODE. CODE should be boxed.
4. Enter laser code on the keypad, then press ENT.
5. New laser code will be visible on scratchpad.



## SECTION STRUCTURE

- **1 – Introduction**
  - Introduction to Weapons
  - My Weapons Control Setup
  - SMS (Stores Management System) Page
  - WPN UFC
  - ASCMI (Armament Stores Management Control Indicator)
  - Bomb Delivery Modes
  - Bomb Altitude Parameters
- **2 – Air-to-Ground Weapons**
  - 2.1 – Unguided Bomb (MK-82 – CCIP)
  - 2.2 – Unguided Bomb (MK-82 – CCRP/AUTO)
  - 2.3 – Laser-Guided Bombs (GBU-12 Paveway II)
  - 2.4 – GAU-12 Gun (Air-to-Ground)
  - 2.5 – Rockets + GAU-12 Gun (Air-to-Ground)
  - 2.6 – AGM-122 Sidarm
  - 2.7 – AGM-65F/G Maverick (IRMV)
  - 2.8 – AGM-65E Maverick (Laser-Guided LMAV)
  - 2.9 – GBU-38 JDAM
    - 2.9.1 – Pre-Planned (AHTS)
    - 2.9.2 – TOO/Target-of-Opportunity (Targeting Pod)
- **3 – Air-to-Air Weapons**
  - 3.1 – GAU-12 Gun
  - 3.2 – AIM-9M Sidewinder

1 – INTRODUCTION  
TO WEAPONS

BOMBS			
WEAPON	TYPE	WEAPON	TYPE
MK-82 LD	500 lbs unguided low-drag bomb	GBU-12	500 lbs laser guided bomb
MK-82SE (Snake Eye)	500 lbs unguided low-drag retarded bomb	GBU-16	1,000 lbs laser guided bomb
MK-82 AIR	500 lbs unguided low-drag ballute equipped bomb	BDU-33	25 lbs unguided training bomb
MK-20 Rockeye	Unguided cluster bomb	GBU-38 JDAM	Global Positioning System (GPS)-guided Joint Direct Attack Munition (JDAM) bombs

Note: GBU stands for Guided Bomb Unit.

GUN POD	
WEAPON	TYPE
GAU-12	Five-barrel 25 mm Gatling-type rotary cannon (300 rounds)

MISSILES	
WEAPON	TYPE
AIM-9M Sidewinder	Infrared guided air-to-air missile
AGM-65F/G Maverick (IRMV)	Air-to-Ground missile guided by imaging infrared system (IRMV) and used at night and during bad weather.
AGM-65E Maverick (LMAV)	Air-to-Ground missile guided by laser designator guidance system (LMAV) optimized for fortified installations and heavier penetrating blast-fragmentation warhead
AGM-122 Sidarm	Air-to-Surface Anti-Radiation Missile

ROCKETS	
WEAPON	TYPE
ZUNI MK-71	130 mm (5 inches) unguided rockets
FFAR	Folding-Fin Aerial Rocket, used as anti-bomber rockets
2.75 in	2.75 inches rocket, used for general purpose

# 1 - MY WEAPONS CONTROLS SETUP



Bomb Pickle

Trigger: Fire Gun/Launch Sidewinder, Sidearm

- ↑ Sensor Sel. FWD: INS, IRMV/EOMV
- Sensor Sel. RIGHT: FLIR/HUD-BH/WH
- ↓ Sensor Sel. AFT: DMT LST/TV
- ← Sensor Sel. LEFT: MAP Center/Decenter
- P Sensor Sel. DOWN: HUD Reject

AG Target Undesignate/NWS/FOV Toggle

- ↑
- 
- ↓
- ←

- ↑ TDC DOWN (ACTION)
- CAGE/UNCAGE (MAVERICK)

- ↑ A/A Mode FWD: Sidewinder (Boresight)
- A/A Mode DOWN: Gun
- ↓ A/A Mode AFT: Sidewinder (SEAM)

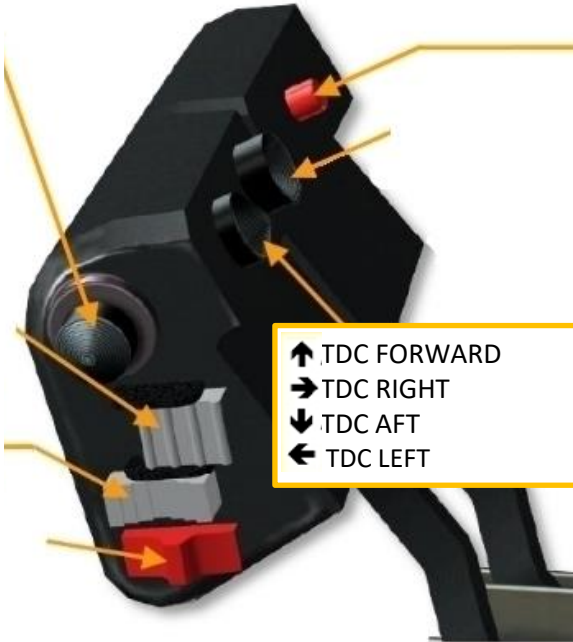

- ↑ TDC FORWARD
- TDC RIGHT
- ↓ TDC AFT
- ← TDC LEFT

# 1 - SMS Page (Stores Management System)

The SMS (Stores Management System) page can be accessed by clicking on the MENU OSB , then selecting the STORES sub-menu.

This page acts like the A-10C’s DSMS (Data & Stores Management Systems) page and allows you to select armament and program useful options like gun firing speed, bomb delivery mode or advanced air-to-air missile modes.

The wingform display provides the number, type, and status of all stores loaded on the aircraft’s weapon stations. A weapons rack is indicated as a diamond symbol, and the number below indicates the number of weapons loaded on the rack or station. The gun rounds remaining is indicated at the top of the wingform (300 being a full load and XXX when empty). The Targeting Pod is indicated by TPOD.

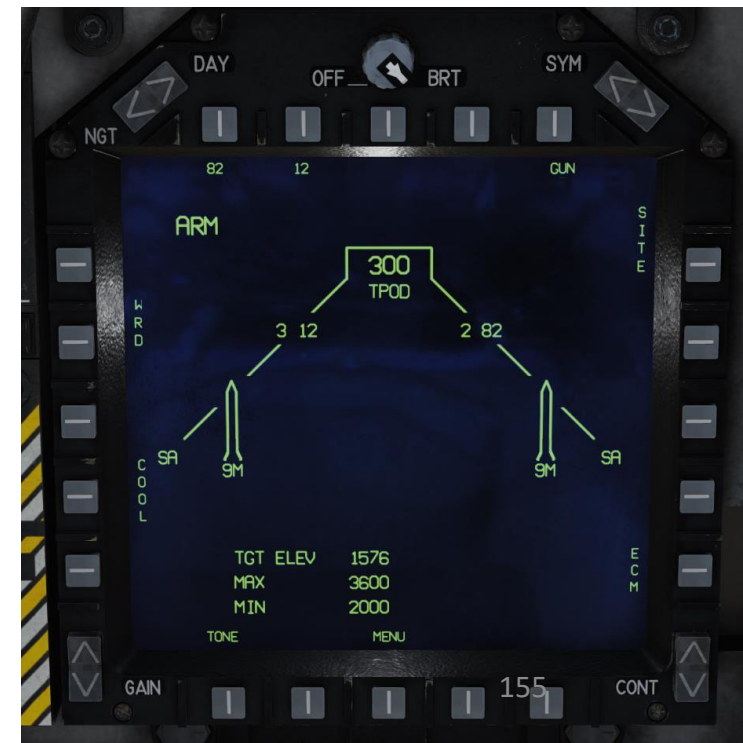
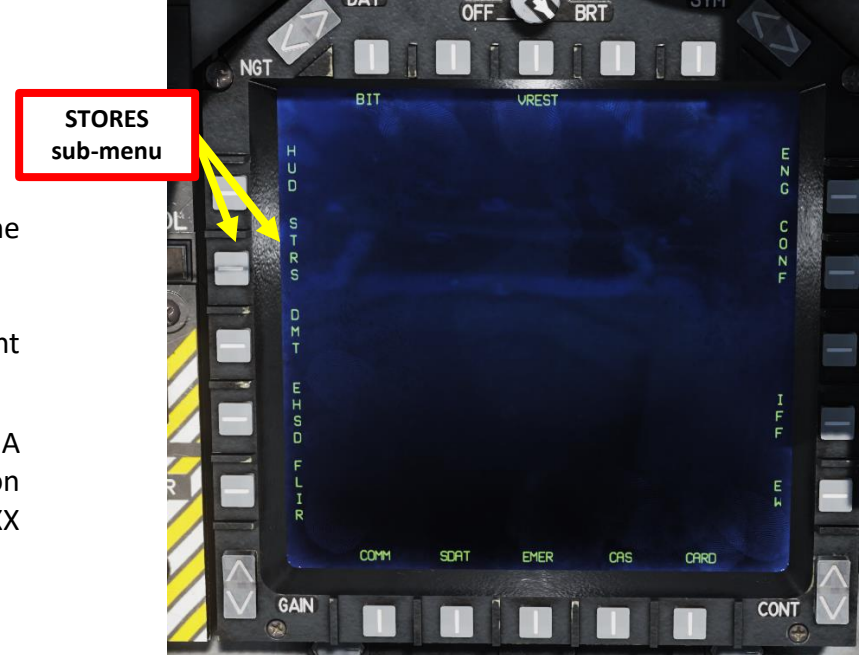

1 – WPN UFC

When a weapon is selected from the STORES page, you can press the « WPN » button the UFC (Up-Front Control) to display weapon parameters. Using the ODU Buttons (« : » means selected) and the UFC Scratchpad, you can set parameters like bomb quantity, fuze, interval, etc. and enter them by pressing the « ENT » button.

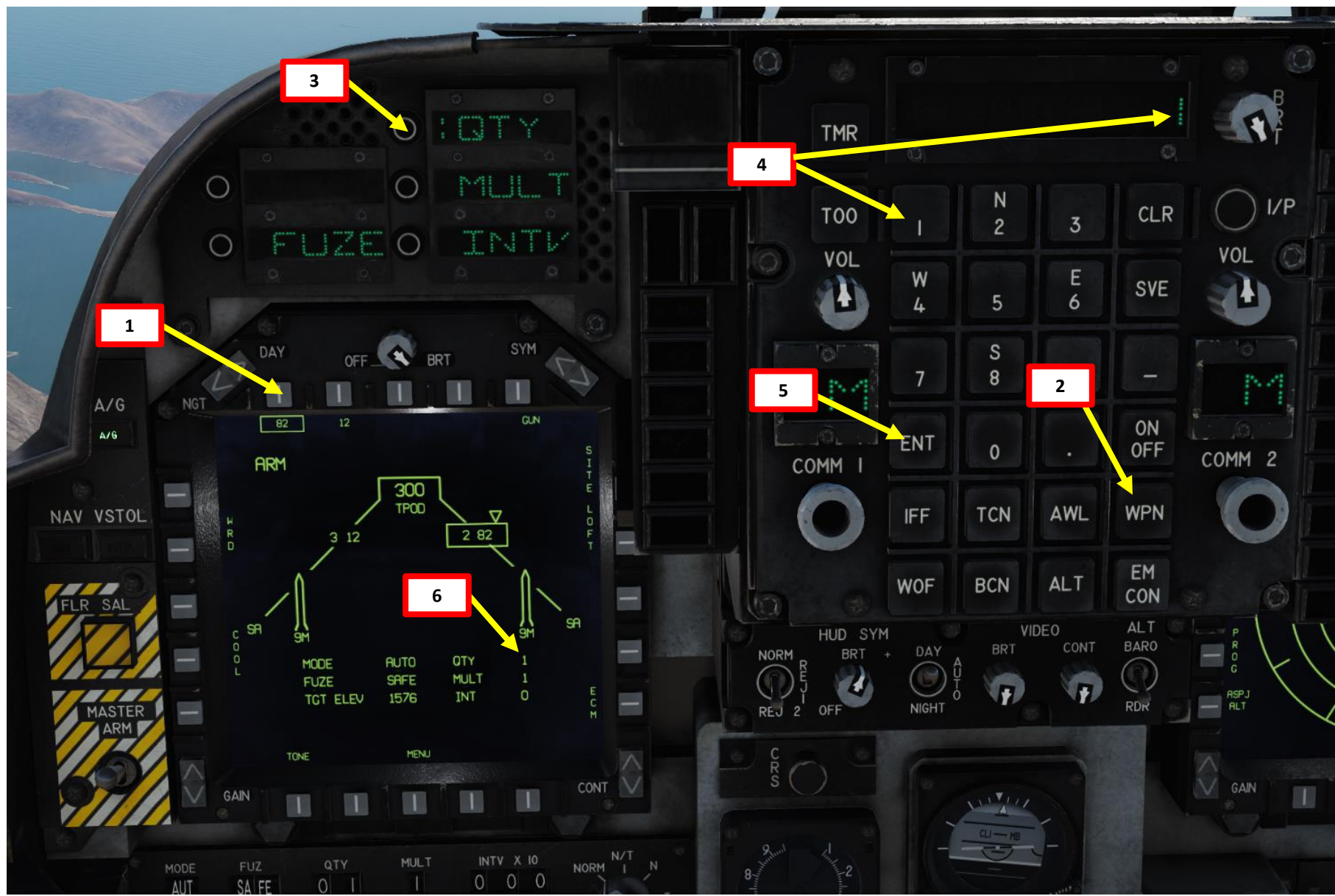

**1 – ASCMI (ARMAMENT STORES MANAGEMENT CONTROL INDICATOR)**

Alternatively, you can also use the ASCMI (Armament Stores Management Control Indicator) to set up weapon release parameters.

**Armament Delivery Mode**  
 AUT: Automatic  
 CIP: CCIP, Continuously Computed Impact Point  
 DSL: Depressed Sight Line  
 DIR: Direct

**Weapon Quantity Control**

**Weapon Multiple Control**

**Weapon Manual Control**  
 NORM: Normal  
 N/T: Nose & Tail Fuzing  
 N: Nose Fuzing  
 T: Tail Fuzing

**ASCMI (Armament Stores Management Control Indicator) Panel**



**Fuzing Control**

**Weapon Interval Control**

**Selective Jettison Control**  
 STA: Selected stations  
 STOR: Selected stores  
 SAFE: Safety Position  
 CMBT: Combat  
 FUEL: External Fuel Tanks  
 PUSHBUTTON: Jettisons selected ordnance

**Station Selection Button & Indication**

**IR (Infrared) Cooling Switch**  
 Applies manual cooling to all sidewinder-equipped stations. You shouldn't be turning it on at all unless you have a system failure that prevents the sidewinder seeker head from cooling or need to cool sidewinder's while on the ground for preflight checks.

**ARMAMENT CONTROL PANEL**

**DELIVERY MODE:** selects weapons delivery mode from the following list:  
 AUT (Automatic), CIP (CCIP), DSL (Depressed sight line), DIR (direct), AGM (for Mavericks and Sidearms)

**FUZING:** see previous page.

**QUANTITY:** Selects the **total** quantity of weapons to be released during a delivery sequence. You cannot select quantity greater than the total number of weapons of the given type carried onboard.

**MULTIPLE:** Selects the number of stations that will simultaneously release their weapons during a delivery sequence. You cannot select a number greater than the number of stations carrying given type of weapon.

**INTERVAL:** Lets you select the release interval for multiple release sequence and represents the ground impact spacing in feet. In order to be able to set the interval, the **Q** must be greater than the **M** setting.

**AVAILABLE OPTIONS**

	QTY	MULT	INTV	FUZ	RANGE
BOMBS	Green	Green	Green	Green	Red
ROCKETS	Green	Green	Red	Green	Green
DISPENSERS	Green	Green	Green	Green	Red
AGM	Green	Red	Red	Green	Green
GUN	Red	Red	Red	Red	Green

## 1 - BOMB DELIVERY MODE CCIP & CCRP (AUTO)

There are 2 traditional ways to deliver a bomb with a computed mode: CCRP or CCIP modes.

**CCIP** mode is the traditional dive bombing approach: you dive on target and the reticle will tell you where the bomb will impact.

However, dive bombing is a risky business, especially if anti-air defences are surrounding your target. The lower you go, the more vulnerable you are. This is why CCRP release mode was invented.

**CCRP** mode allows you to fly straight and level without having to dive down. The HUD will tell you when to release your bomb for the target you have designated with your radar. It is a much safer way to release a bomb, but as you may have guessed already, it is less precise. CCRP mode is also referred to the AUTO mode.

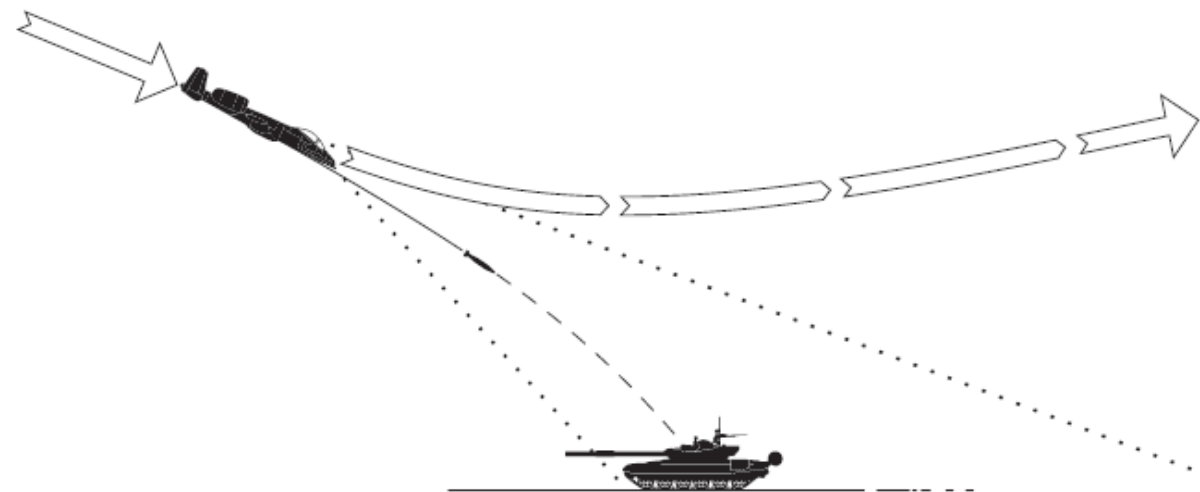

**CCIP: Continuously Computed Impact Point**

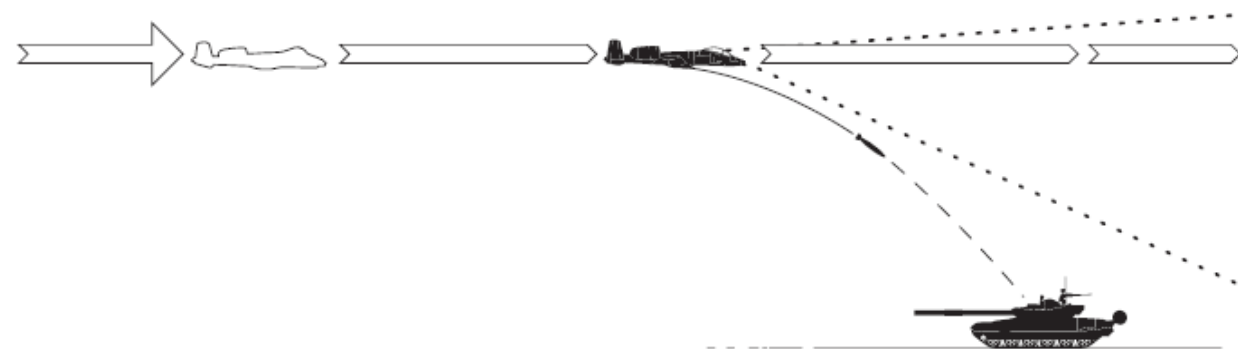

**CCRP: Continuously Computed Release Point**

# 1 - BOMB DELIVERY MODE DSL, DIR, & DSL1

There are three backup methods to deliver a bomb: DSL (Depressed Sight Line), DIR (Direct Delivery) or DSL (1) modes. These modes are similar to the dive bombing techniques used in the Vietnam War era; bombs are released according to specific delivery altitude and airspeed parameters.

**DSL** (Depressed Sight Line) mode is used when the Mission Computer, INS, HUD or avionics multiplex data bus fail. DSL Mode is only selectable from the Armament Control Panel. You need to meet specific, pre-determined release conditions such as altitude and dive angle.

**DIR** (Direct) mode displays a roll stabilized sight very similar to the DSL mode. DIR should be programmed prior to taxi. In order to do so, deselect all stations, set A/G Master Mode and then choose DIR on the Armament Control Panel. Bomb delivery technique is the same as for normal DSL mode.

**DSL (1)** mode is last of the backup modes, allowing to drop bombs if both Stores Management Computer and Armament Control Panel fail. It enables the pilot to use manual duze arming. In this mode, you can only drop one bomb with each press of the Bomb Pickle button. Bomb delivery technique is the same as for normal DSL mode.



## DSL DELIVERY MODE PROCEDURE

The DSL mode provides weapon delivery capability when system failures prevent you from using any other modes. It provides pilot with a roll - stabilised reticle with manually adjusted depression angle.

1. Select the A/G Master Mode.
2. Select the desired weapon using the DDI, ODU or ACP.
3. Set up the Fuzing, Quantity, Multiple and Interval as required.
4. Choose DSL delivery mode on the ACP.
5. Press the SITE on Stores Page (P/B 12).
6. On the ODU make sure that SITE is colonised and enter required depression angle.
7. Align the Bomb Fall Line (BFL) with the target.
8. Make sure that your wings are level, enter a dive at required angle and speed. Hold the reticle 2-3 degrees above the target.
9. When reticle reaches the target at required altitude, press pickle button.
10. Pull hard across the horizon, verify the outcome of your attack.
11. Set Master Arm Switch to OFF.

The depression angle can be set between 0 and 240 mils.

When diving on the target, set your TVV 2-3 degrees above it holding a desired dive angle (if you put it on the target, you will not be able to walk the reticle to it).

Use sample settings listed on the next page to set up your bombing runs.



## DSL DELIVERY MODE SAMPLE TABLES (at 450 KTAS)

Mk82/ BDU-33

Starting altitude	Dive angle	Roll-in range	Release altitude	Sight angle
5000	10	4.7 Nm	2000	182
7000	20	3.2 Nm	2500	155
8000	30	2.3 Nm	3000	141
10000	45	1.7 Nm	4000	112

Mk82/ Low Drag

Starting altitude	Dive angle	Roll-in range	Release altitude	Sight angle
5000	10	4.7 Nm	2000	216
7000	20	3.2 Nm	2500	186
8000	30	2.3 Nm	3000	163
10000	45	1.7 Nm	4000	136

Mk82/ High Drag

Starting altitude	Dive angle	Roll-in range	Release altitude	Sight angle
2000	10	1.9 Nm	600	169
5000	20	2.3 Nm	1100	187
8000	30	2.2 Nm	2000	202

GBU-12/ Low Drag

Starting altitude	Dive angle	Roll-in range	Release altitude	Sight angle
7000	10	6.5 Nm	2500	239
9000	20	4.0 Nm	3000	204
12000	30	3.4 Nm	4000	189
14000	45	2.3 Nm	5000	152

# 1 – BOMB ALTITUDE PARAMETERS

Having accurate data for altitude is crucial for precise weapons delivery. The Harrier can obtain this data from various sensors and systems with different levels of accuracy. **ARBS (Angle Rate Bombing System), Radar Altimeter, GPS and barometric altitude are the four main sources for altitude reference.**

1. To select your altitude source for bombing, press the “ALT” button on the UFC (Up-Front Control).
2. The **BOMB** ODU, when selected (“:”), uses the radar altimeter for ballistic computation by the mission computer. When selected, BOMB ODU will display on the scratchpad the last selected LAW (Low Altitude Warning), which you can modify. You need to make sure your radar altimeter is ON (ON/OFF switch)
3. The **GPS** ODU, when selected (“:”), uses the GPS for ballistic computation by the mission computer.
4. If neither the DMT (Dual Mode Tracker) of the ARBS, BOMB or GPS is selected, the **barometric** altitude source is used by default. However, you will need to make sure you have the correct barometric setting entered on the Standby Altimeter.

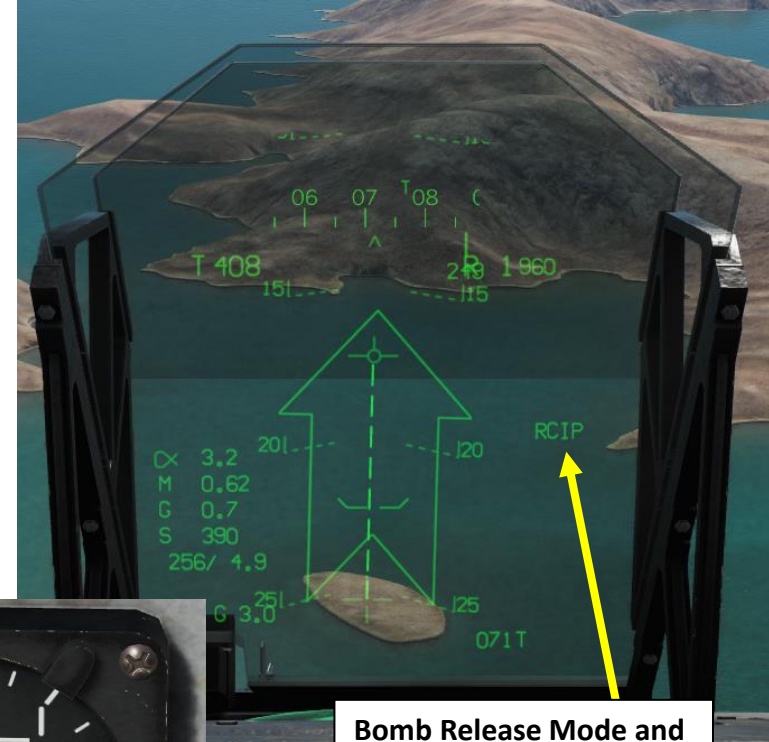

Bomb Release Mode and Altitude Source

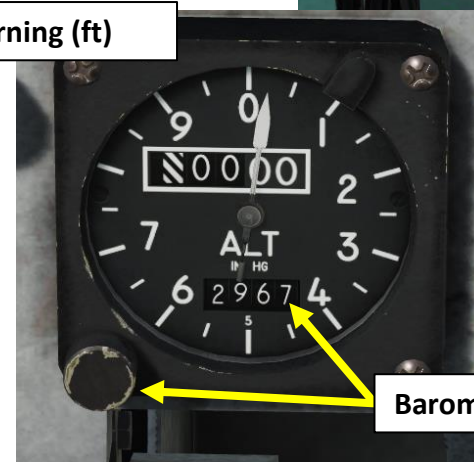

Barometric Setting (in Hg)

Depending on the system currently working, the following legend will appear on the HUD:

SYSTEM	AUTO	CCIP
ARBS	AUTO	CCIP
RADAR ALT.	RAUT	RCIP
GPS	GAUT	GCIP
BAROMETRIC ALT.	BAUT	BCIP <sup>160</sup>

# 1 – BOMB ALTITUDE PARAMETERS

You can also program for a Pull-Up Cue altitude. When you are 9 seconds from reaching the selected pullup altitude, the PUC symbol appears below the Velocity Marker. It will climb towards the Velocity Marker as you get closer to the pullup altitude. The moment it reaches the VVM you are at the pullup altitude.

1. Press the “ALT” button on the UFC (Up-Front Control).
2. Select the PUC (Pull-Up Cue) ODU (“:” when selected)
3. Enter on the UFC scratchpad the desired Pull Up altitude in ft, then press ENT.

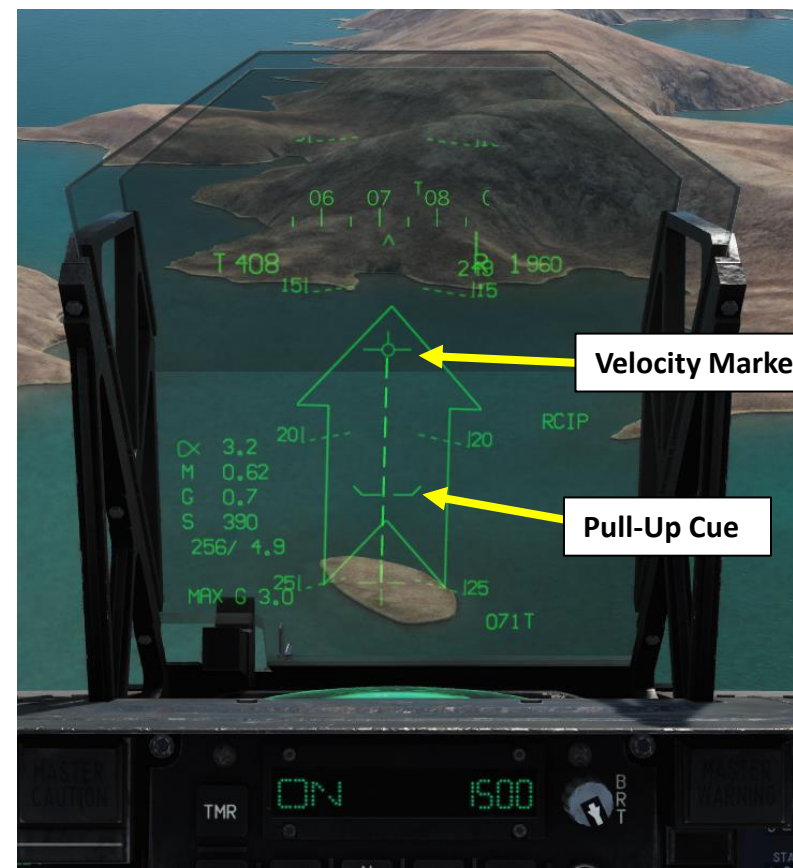

## 2.1 - UNGUIDED BOMB - CCIP

1. Set HUD Master Mode to A/G (Air-to-Ground)
2. Go in MPCD main MENU
3. Select STRS (Stores) Page
4. Select desired MK82 bombs by either selecting them with the upper OSB (Option Select Button) or by pressing the pylon SEL buttons on the ACP (Armament Control Panel).
5. Select CIP (CCIP) Armament Mode
6. Set Fuzing to desired mode (N IN for this tutorial)
7. Set desired Bomb Quantity (total bombs to be dropped)
8. Set Multiple parameter to the number of pylons used (how many pylons are used to drop the total bomb quantity; we will use 2 in order to avoid asymmetrical loadouts).
9. Set desired Interval (distance between bombs dropped in ft). In order to be able to set an interval, Bomb Quantity needs to be greater than the Multiple parameters. Since this isn't the case, we will leave Interval at 0.
10. Set Master Arm Switch - ON (UP)
11. Press the ALT button on the UFC and verify that Radar Altimeter is ON, BOMB and GPS options are selected.
12. Select the PUC (Pull-Up Cue. « : » when selected), set desired altitude (4000 ft in our case), then press ENT on the UFC.
13. Set HUD Altitude Selector to RDR (Radar Altimeter)



## 2.1 - UNGUIDED BOMB - CCIP

14. Perform a 45 degree dive on the target and fly to align the vertical CCIP line with the target.
15. At first, the CCIP cross will be dashed: this means your aircraft is not yet stabilized and ready to drop its bombs.
16. When CCIP cross becomes a solid cross, you can drop your bombs when the CCIP cross is aligned on your target.
17. When you are 9 seconds from reaching the selected Pull-Up altitude, the PUC (Pull-Up Cue) symbol appears below the Velocity Marker. It will climb towards the Velocity Marker as you get closer to the pullup altitude. The moment it reaches the Velocity Marker you are at the pullup altitude. The trick is to release before the PUC reaches the VVM and to make a 4G climb so you never go below the pullup altitude. Take note that the PUC symbol will be hidden most of the time, and will only appears when you are diving.
18. Press the Bomb Pickle button (RALT+SPACE) to drop your bombs
19. A Target Point will automatically be created once bombs are dropped.

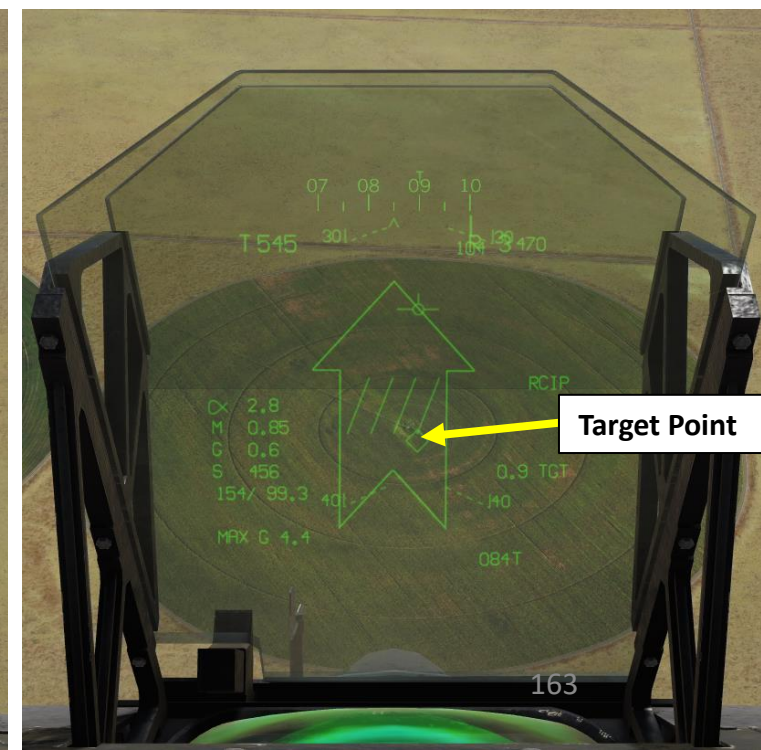
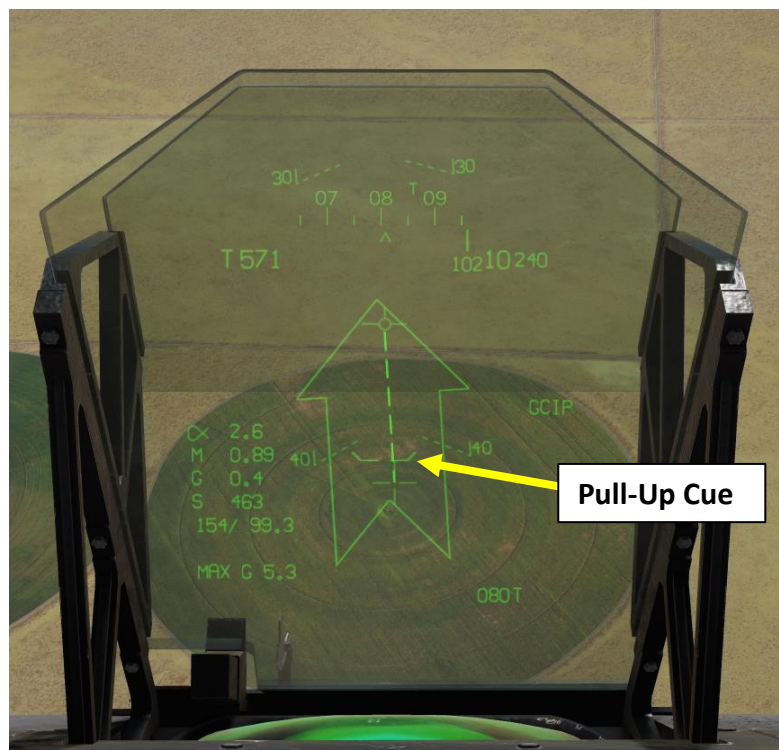
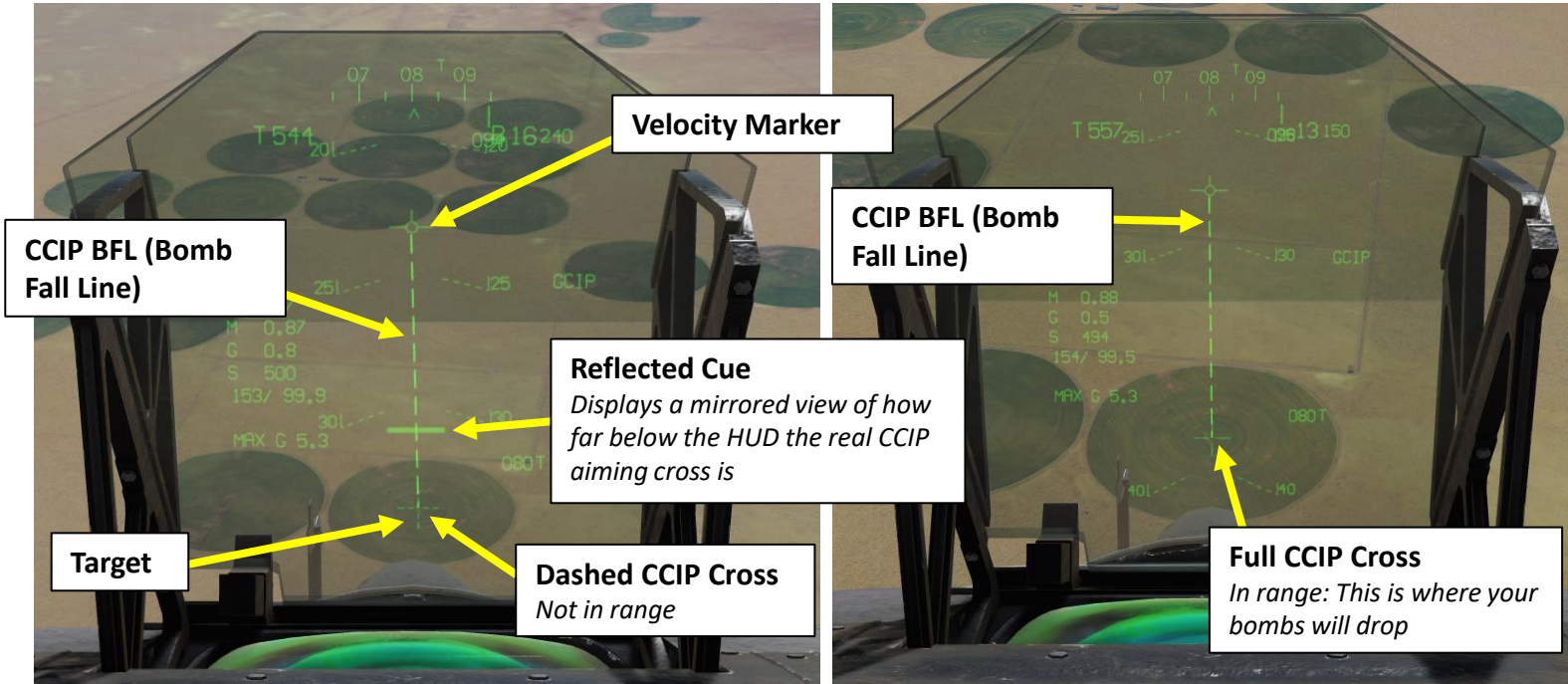
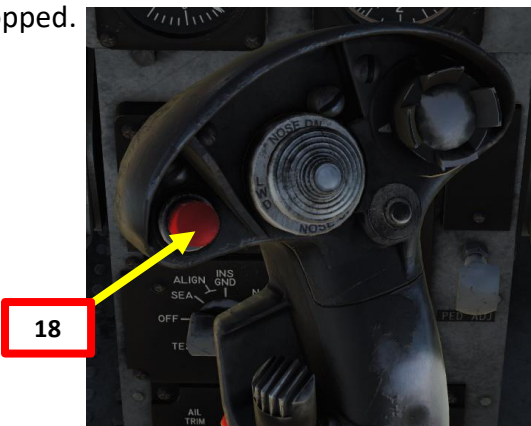

2.1 - UNGUIDED BOMB - CCIP



## 2.1 - UNGUIDED BOMB - CCIP NOTE ON CCIP REFLECTED CUE

Between the CCIP piper and the velocity vector marker is the Reflected cue (or Delayed Cue).

When the Reflected cue is visible on the BFL (Bomb Fall Line), it indicates that the CCIP piper on the HUD is not showing the true impact point if you were to drop the bomb at that moment.

Instead, the true impact location is a mirror of the distance from the Reflected Cue to the CCIP piper. When Reflected Cue disappears, the CCIP piper will then indicate the true impact point.

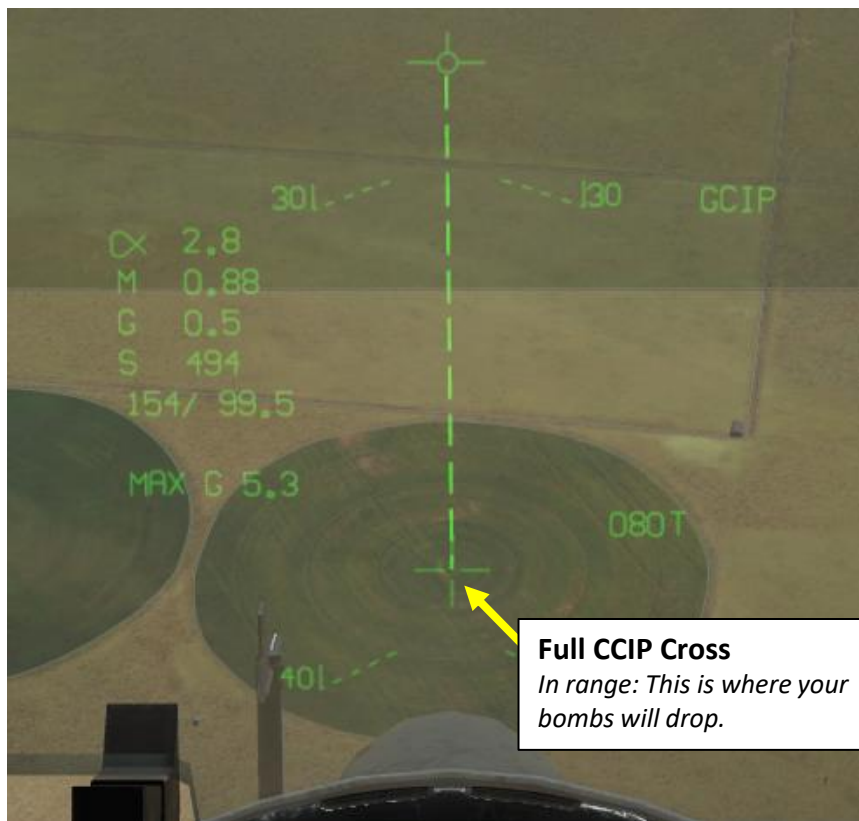

**Full CCIP Cross**  
*In range: This is where your bombs will drop.*

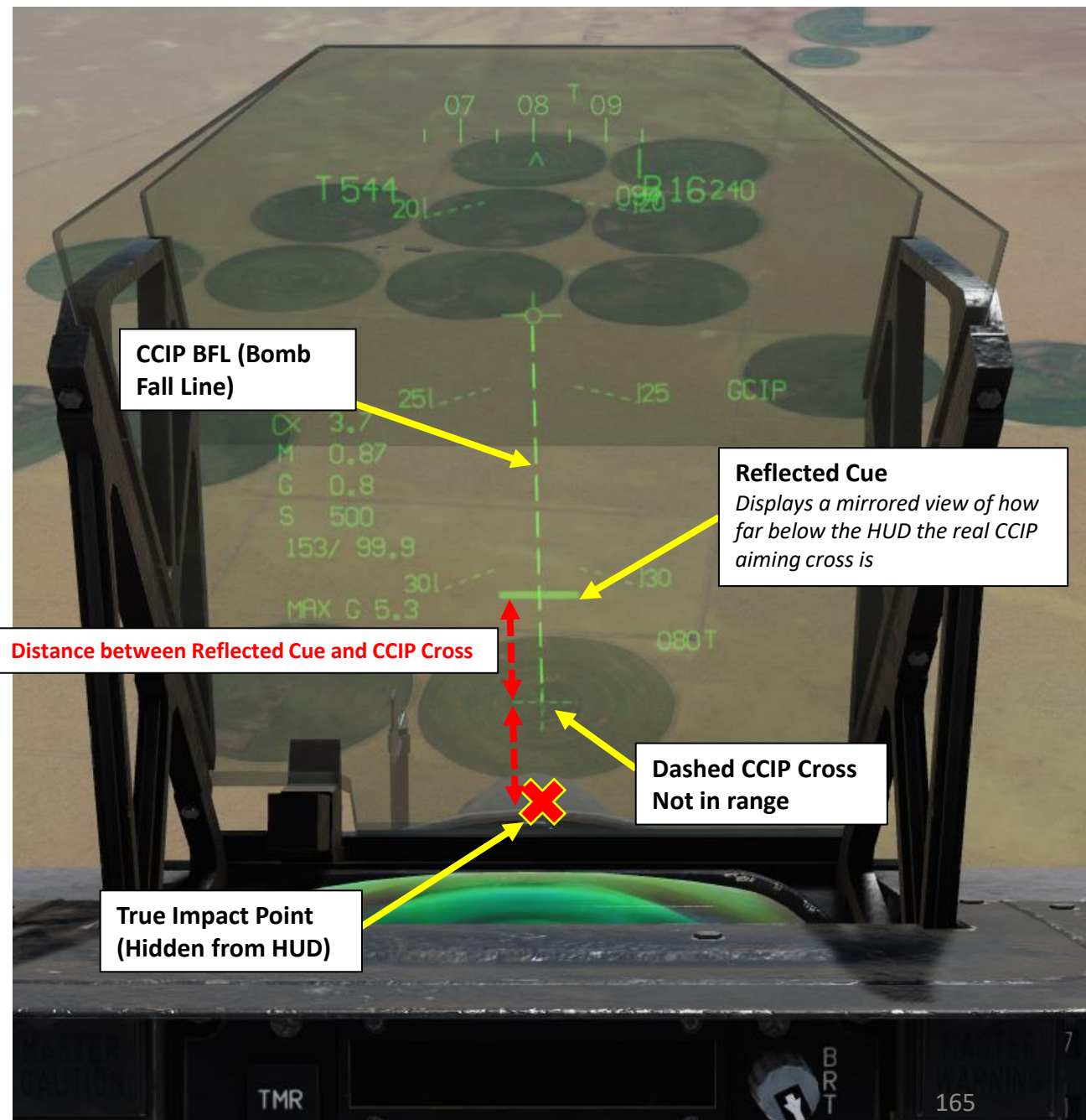

**CCIP BFL (Bomb Fall Line)**

**Reflected Cue**  
*Displays a mirrored view of how far below the HUD the real CCIP aiming cross is*

**Distance between Reflected Cue and CCIP Cross**

**Dashed CCIP Cross Not in range**

**True Impact Point (Hidden from HUD)**

## 2.1 - UNGUIDED BOMB - CCIP NOTES ON CCIP (AUTO) MODE

### Note 1:

When CCIP Mode is selected and the CCIP Reflected Cue is visible (meaning that the CCIP cross is dashed and the actual aiming point is outside of the HUD), **pressing the Bomb Pickle Button quickly** will create a Target Point and slave the DMT (Dual Mode Tracker) to the location of the Aiming Reticule. You can then switch to CCRP AUTO mode if desired by **pressing the CAGE/UNCAGE button** on the throttle.

### Note 2:

**Pressing and Holding the Bomb Pickle Button** will switch designate the target on the CCIP cross, and temporarily switch bomb release mode from CCIP to CCRP for as long as you keep the Bomb Pickle button pressed. This allows you to designate a target quickly while in a dive and then perform a level bombing run or a shallow dive bombing run. This is useful for cases where you find a target and realize a dive bombing run is too dangerous.

See Redkite's CCIP Upgrade video on the Harrier:

<https://youtu.be/8tgrkiBmAng>

Before Long Pickle Press

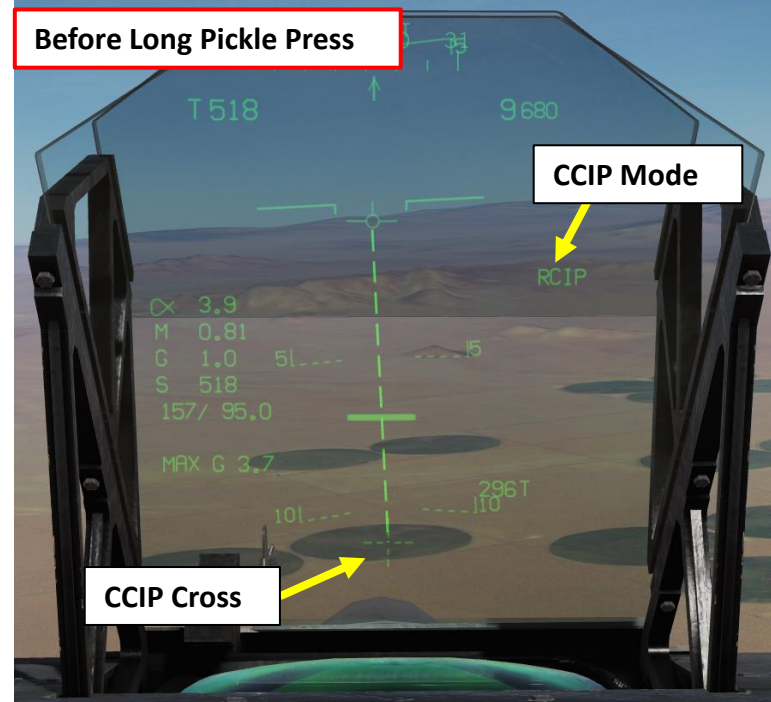

During Long Pickle Press

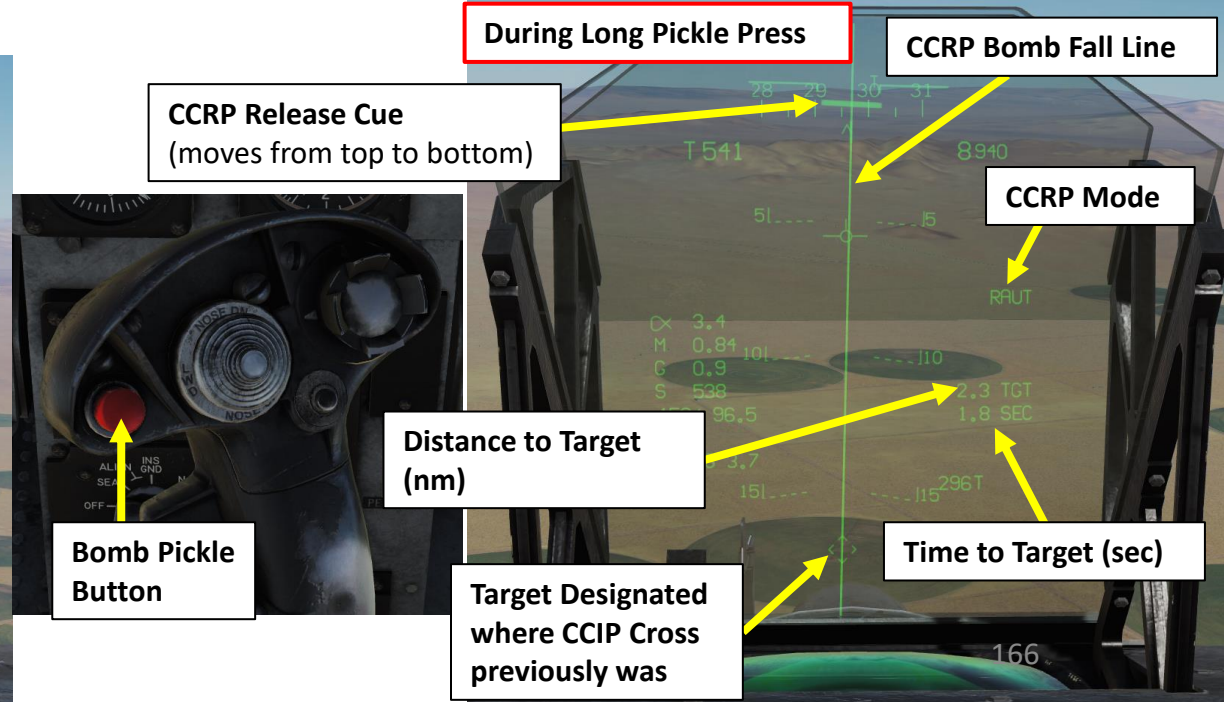

Quick Pickle Press

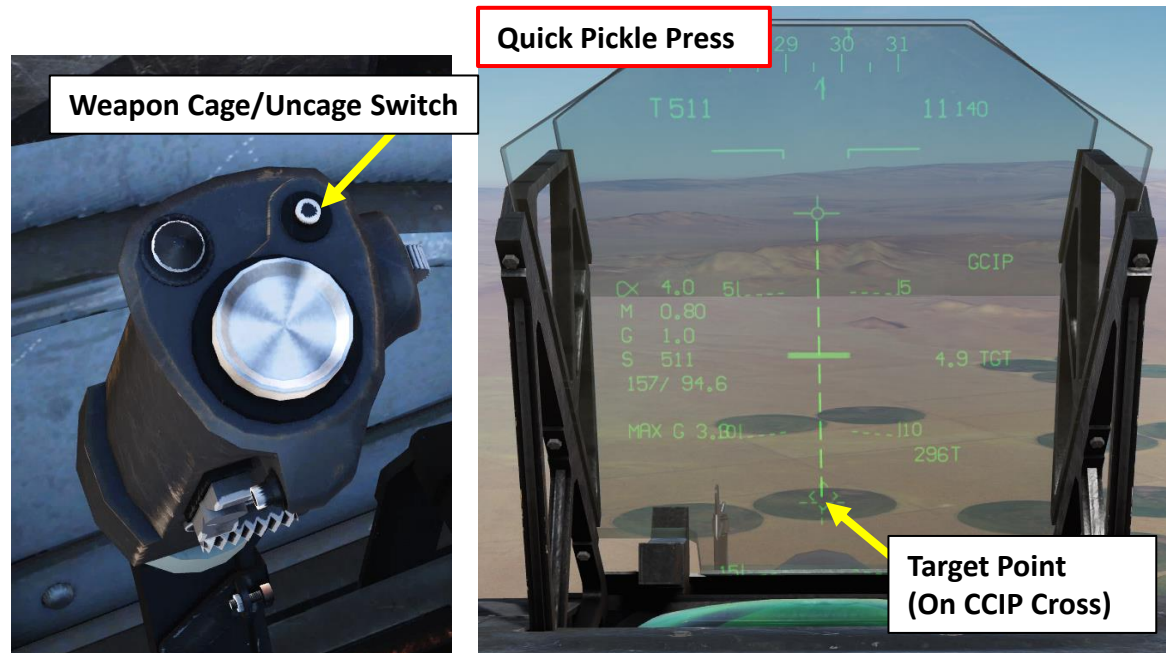

## 2.2 - UNGUIDED BOMB - CCRP

1. Set HUD Master Mode to A/G (Air-to-Ground)
2. Go in MPCD main MENU
3. Select STRS (Stores) Page
4. Select desired MK82 bombs by either selecting them with the upper OSB (Option Select Button) or by pressing the pylon SEL buttons on the ACP (Armament Control Panel).
5. Select AUTO (CCRP) Armament Mode
6. Set Fuzing to desired mode (N IN for this tutorial)
7. Set desired Bomb Quantity (total bombs to be dropped)
8. Set Multiple parameter to the number of pylons used (how many pylons are used to drop the total bomb quantity; we will use 2 in order to avoid asymmetrical loadouts).
9. Set desired Interval (distance between bombs dropped). In our case, we will choose 0.
10. Set Master Arm Switch - ON (UP)
11. Select EHSD (Electronic Horizontal Situation Indicator) page, then press OSB next to DESG to designate the target on your currently selected steerpoint (STP).

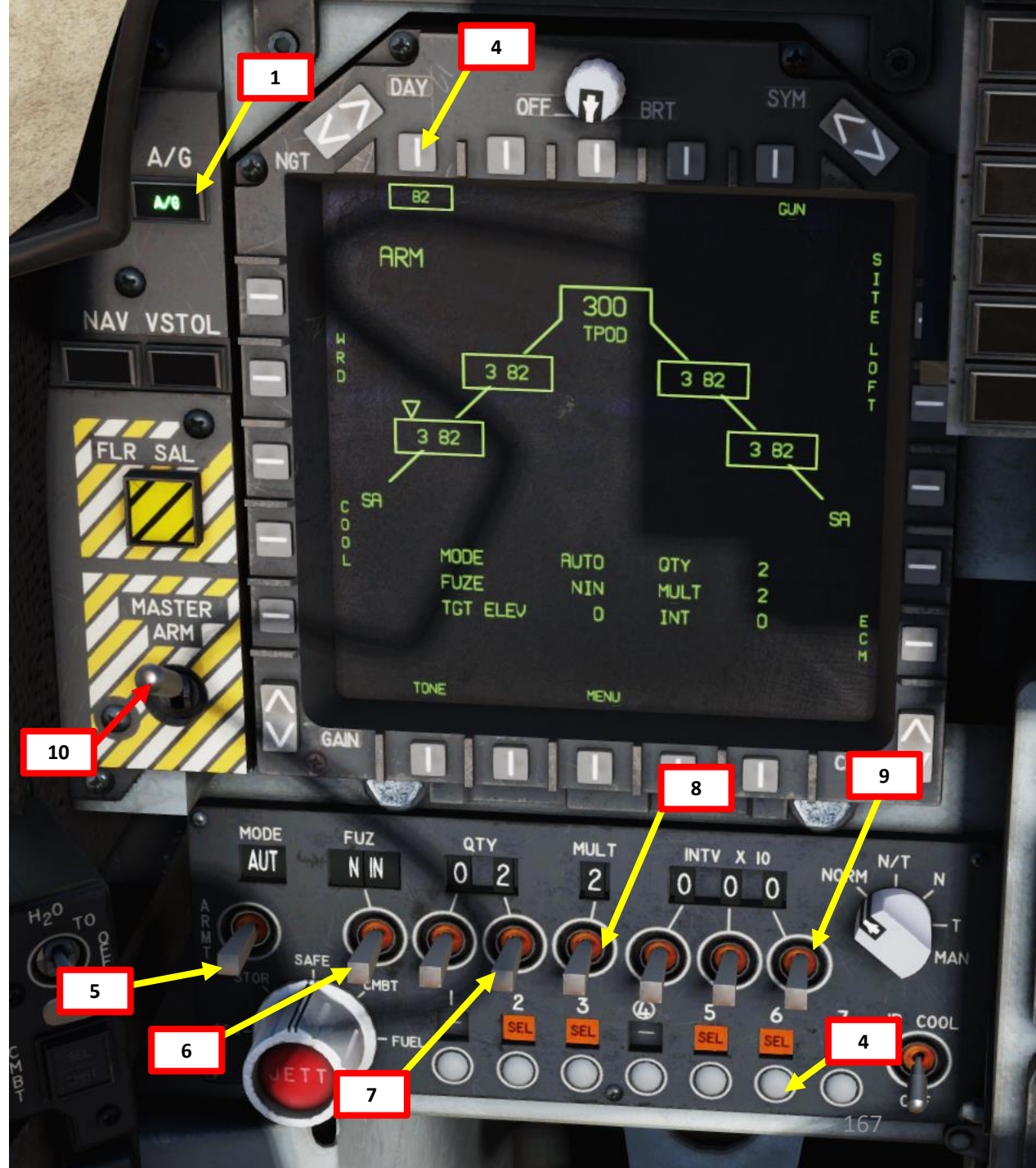
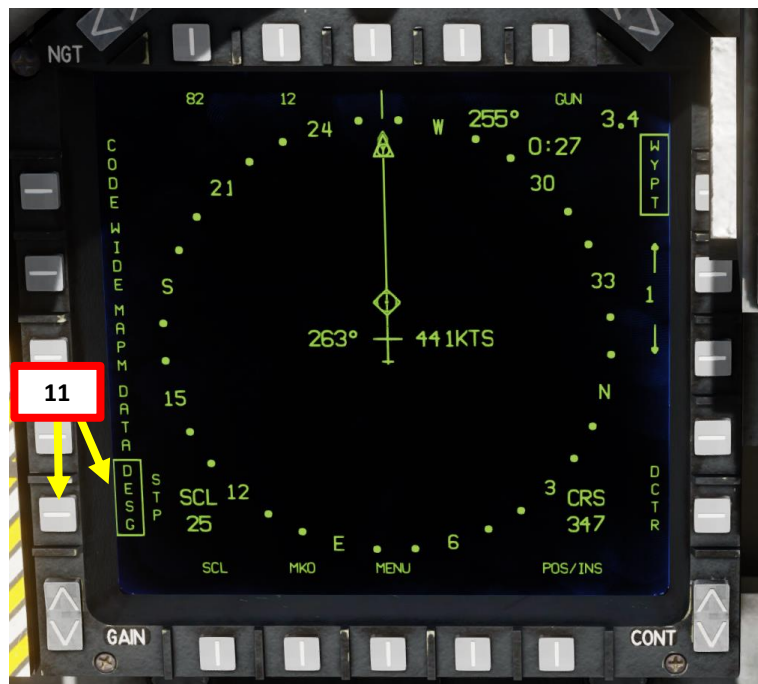

## 2.2 - UNGUIDED BOMB - CCRP

12. Set DMT (Dual Mode Tracker) Power Switch ON (UP)
13. Press the Sensor Select Switch AFT twice to toggle LST/TV Mode of the DMT to TV. DMT feed will appear on your MPCD displays.
14. Press the « AG Target Undesignate/NWS/FOV Toggle » to undesignate target once target is destroyed.
15. At first, TV Mode tracks your aircraft's flight path vector (where your nose is pointing).
16. Press the « TDC DOWN Action Position » button to slave the DMT to a designated target.
17. Once target is designated, you can slew the DMT more precisely using the TDC LEFT/RIGHT/FORWARD/AFT controls. You will be tracking the ground, NOT the target.
18. On the EHSD, the DESG mode will switch from STP (Steerpoint) to TGT (Target).
19. Press the "WP Increment" HOTAS Key for more than 1 second to slave your sensors to Target Point TO. Symbology for CCRP (Auto) Release will then become visible.

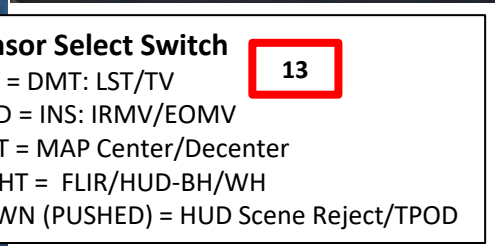
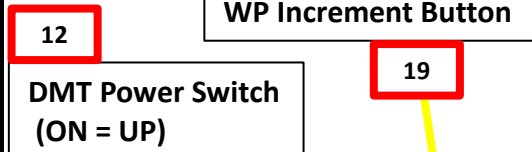
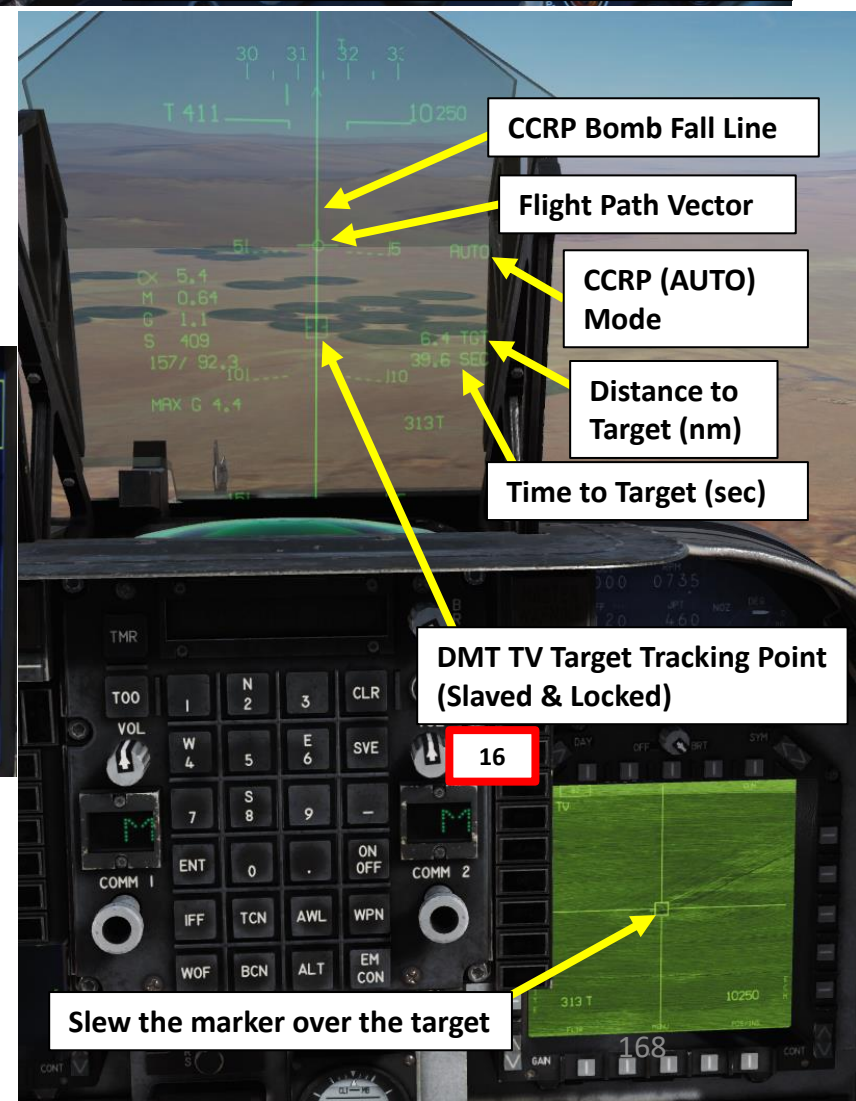
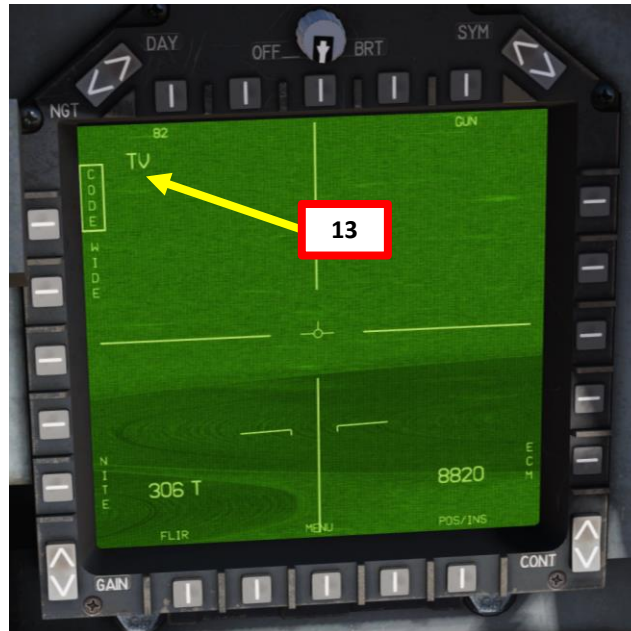

## 2.2 - UNGUIDED BOMB - CCRP

20. Fly level and manoeuvre to align the vertical CCRP line with your flight path vector as much as possible.
21. The time to release is indicated on the HUD.
22. When time is about 10 seconds before release, hold down the Bomb Pickle button (RALT+SPACE).
23. As you fly over Release Point cue (will be indicated by a green horizontal line descending from top to bottom), your bombs will drop automatically provided that you are holding the Bomb Pickle button.
24. Press the « AG Target Undesignate/NWS/FOV Toggle » to un-designate target once target is destroyed.
25. As you will see, CCRP is not a very precise bombing method with unguided bombs.

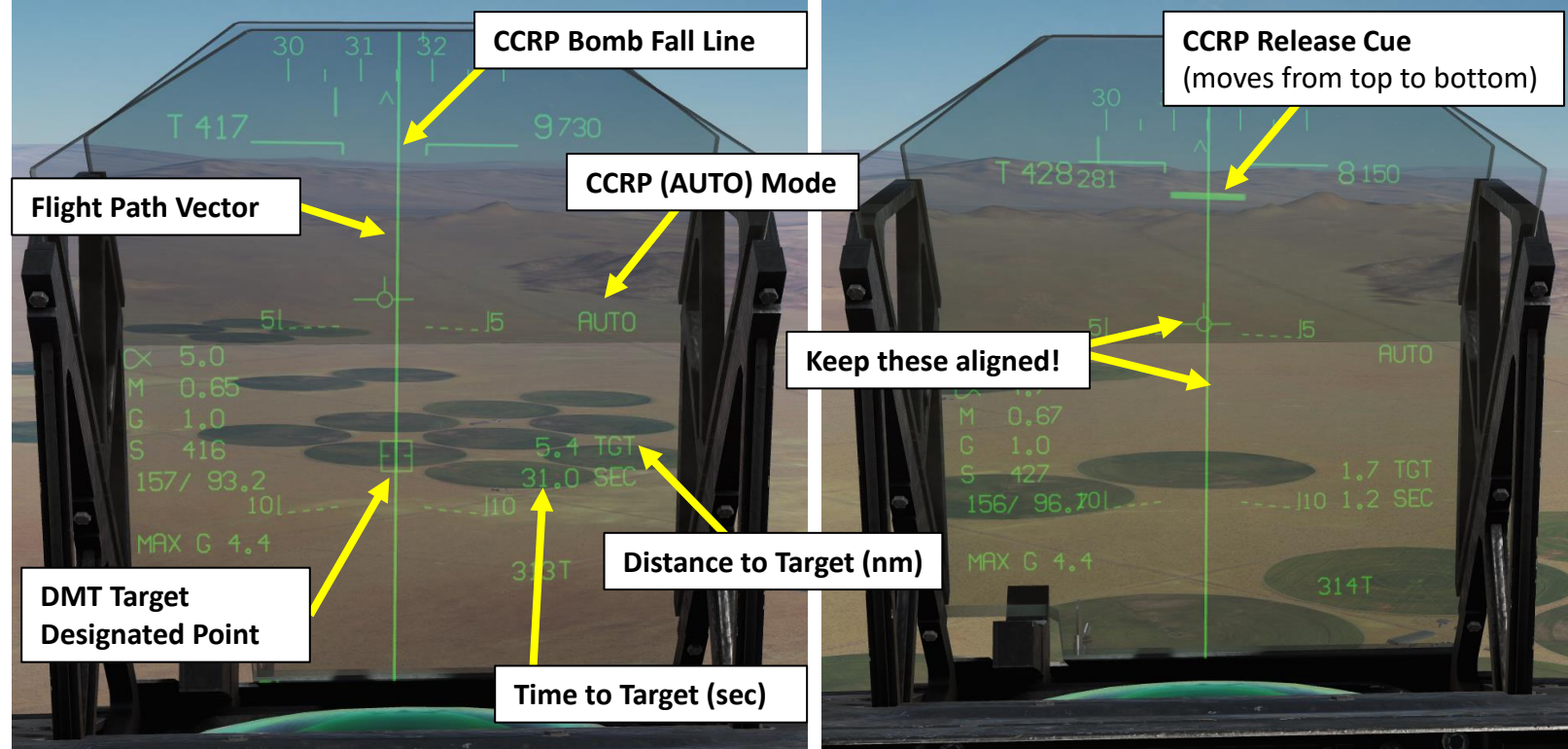

## 2.3 - LASER-GUIDED BOMBS (GBU)

The TPOD (Targeting Pod) is used as an alternate sensor to the DMT (Dual Mode Tracker). We will use it to lase the target. Laser-guided bombing can also be done by buddy-lasing or by using a JTAC.

1. Set HUD Master Mode to A/G (Air-to-Ground)
2. Go in MPCD main MENU
3. Select STRS (Stores) Page
4. Select desired GBU12 bombs by either selecting them with the upper OSB (Option Select Button) or by pressing the pylon SEL buttons on the ACP (Armament Control Panel).
5. Select AUTO (CCRP) Armament Mode
6. Set Fuzing to desired mode (T IN for this tutorial)
7. Set desired Bomb Quantity (total bombs to be dropped)
8. Set Multiple parameter to the number of pylons used (how many pylons are used to drop the total bomb quantity; we will use 2 in order to avoid asymmetrical loadouts).
9. Set desired Interval (distance between bombs dropped). In our case, we will choose 0.
10. Set Master Arm Switch - ON (UP)
11. Select EHSD (Electronic Horizontal Situation Indicator) page, then press OSB next to DESG to designate the target on your currently selected steerpoint (STP).

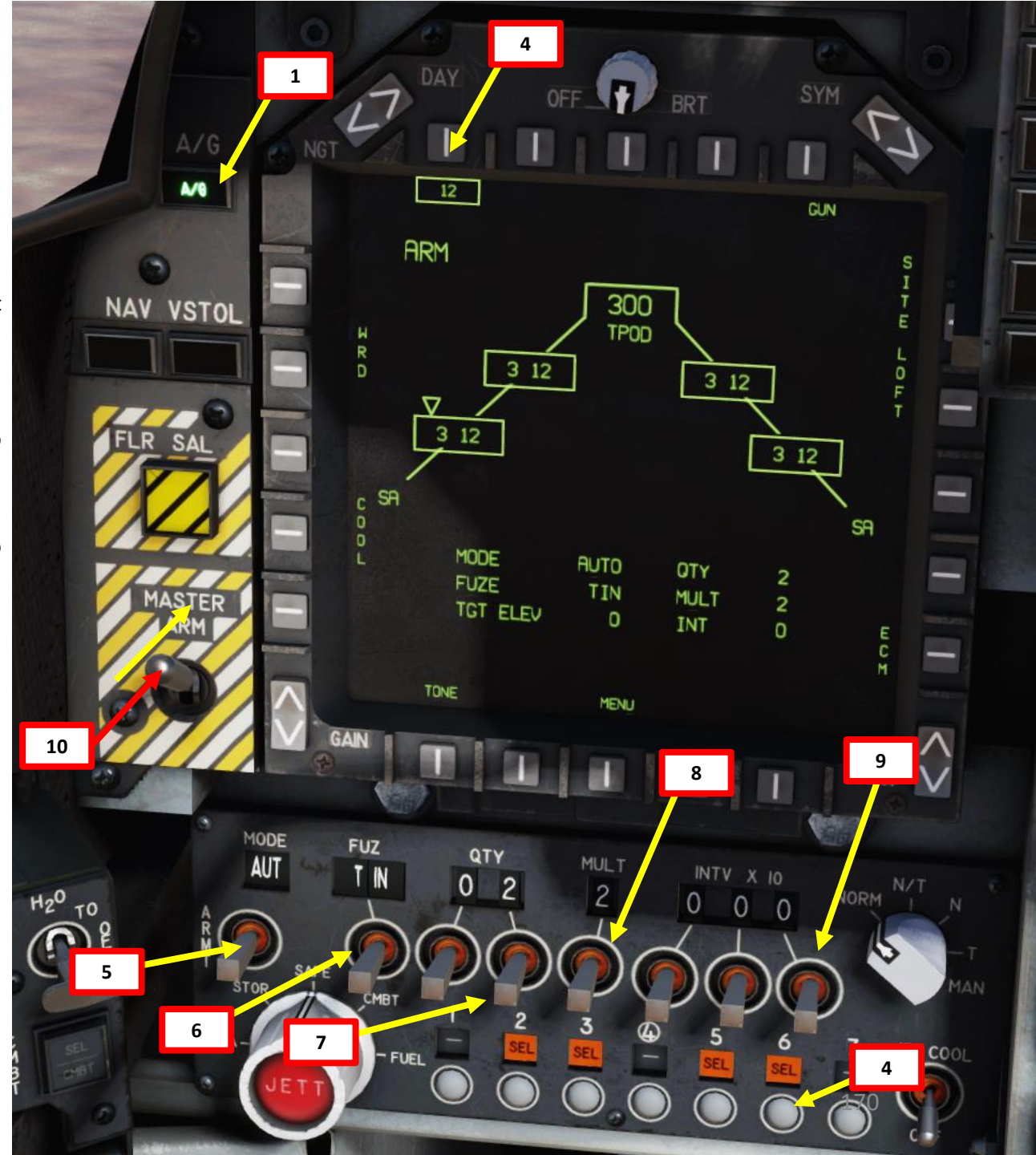
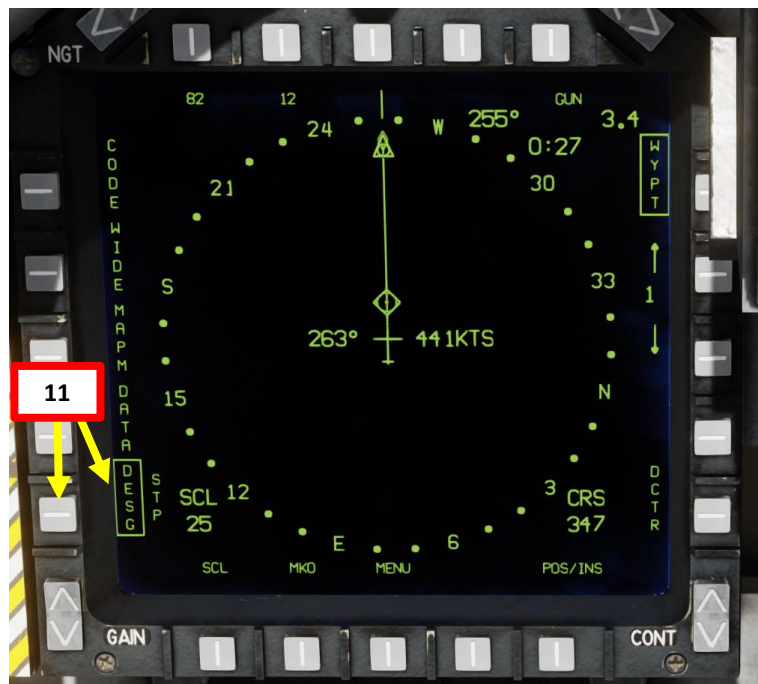

## 2.3 - LASER-GUIDED BOMBS (GBU)

12. Set laser code to 1688: Go in EHSD page, press the OSB (Option Select Button) next to CODE (should be boxed), then set required laser code on the keypad (standard code is **1688**), then press ENT. Unbox CODE by pressing OSB again. Default laser code **1111** is an initialization code **and will not work**.
13. Power up the Targeting Pod:
  - a) Click on the OSB next to the “TPOD” page in the main MPCD MENU
  - b) Clicking the OSB next to STBY
  - c) The Targeting Pod will start its initialization for 3 minutes.
  - d) After initialization, the pod starts FLIR cooling, which takes approximately 6 to 8 minutes. Pod will display F-NOTRDY (FLIR Not Ready) indication when FLIR cooling is incomplete.
14. In order to use the TDC (Target Designation Caret), press the Sensor Select Switch DOWN twice to use TPOD Mode.
15. Select desired Laser Options (LASR)
16. Arm Laser (ARMED)
17. Slew your TDC using the TDC LEFT/RIGHT/FWD/AFT controls.
18. Press the « TDC DOWN Action Position » button to designate a target. Press the Sensor Select Switch AFT short to toggle between area track (AR) and point track (PT).
19. Fire Laser to lock targeting pod on target and lase it.

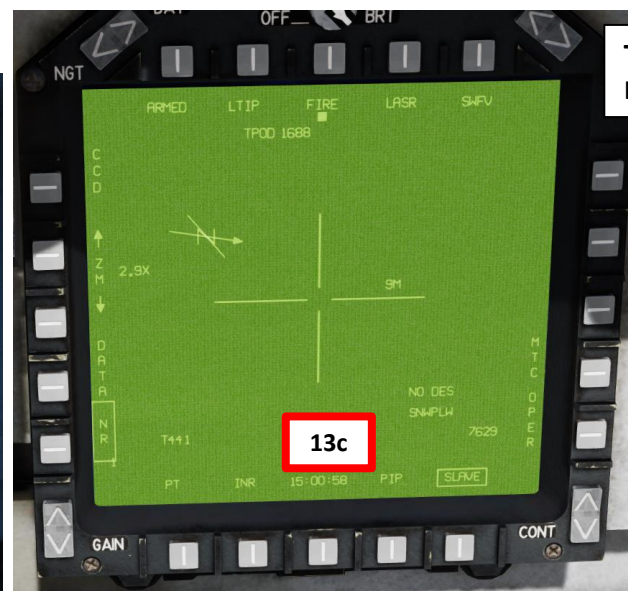
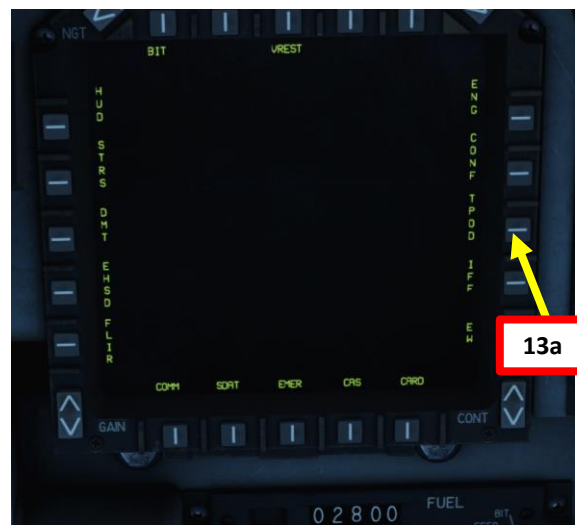
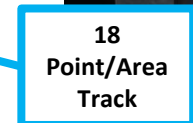
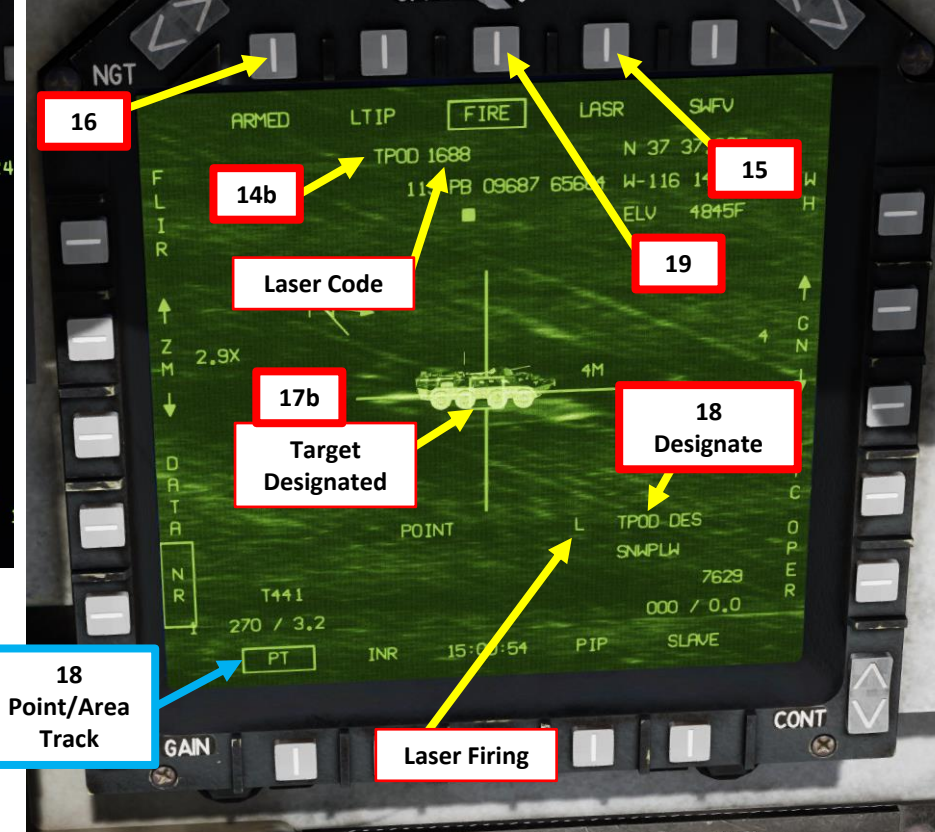
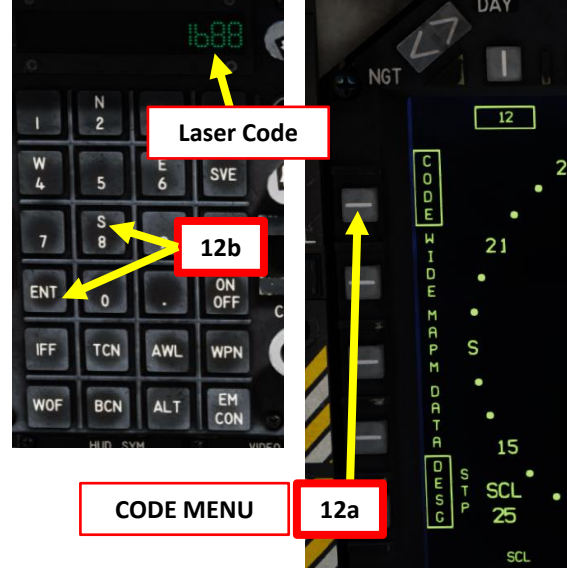

**TDC (Target Designation Caret) Control Switch LEFT/RIGHT/FORWARD/AFT/DOWN (ACTION)**



## 2.3 - LASER-GUIDED BOMBS (GBU)

20. On the EHS, the DESG mode will switch from STP (Steerpoint) to TGT (Target) once target is designated.
21. Press the “WP Increment” HOTAS Key for more than 1 second to slave your sensors to Target Point T0. Symbology for CCRP (Auto) Release will then become visible.
22. Fly level and manoeuvre to align the vertical CCRP line with your flight path vector as much as possible.
23. The time to release is indicated on the HUD.
24. When time is about 10 seconds before release, hold down the Bomb Pickle button (RALT+SPACE).
25. As you fly over Release Point cue (will be indicated by a green horizontal line descending from top to bottom), your bombs will drop automatically provided that you are holding the Bomb Pickle button and guide themselves to the laser spot targeted by the Targeting Pod.
26. Press the « AG Target Undesignate/NWS/FOV Toggle » to un-designate target once target is destroyed.
27. As you will see, guided bombs are very precise and very effective.

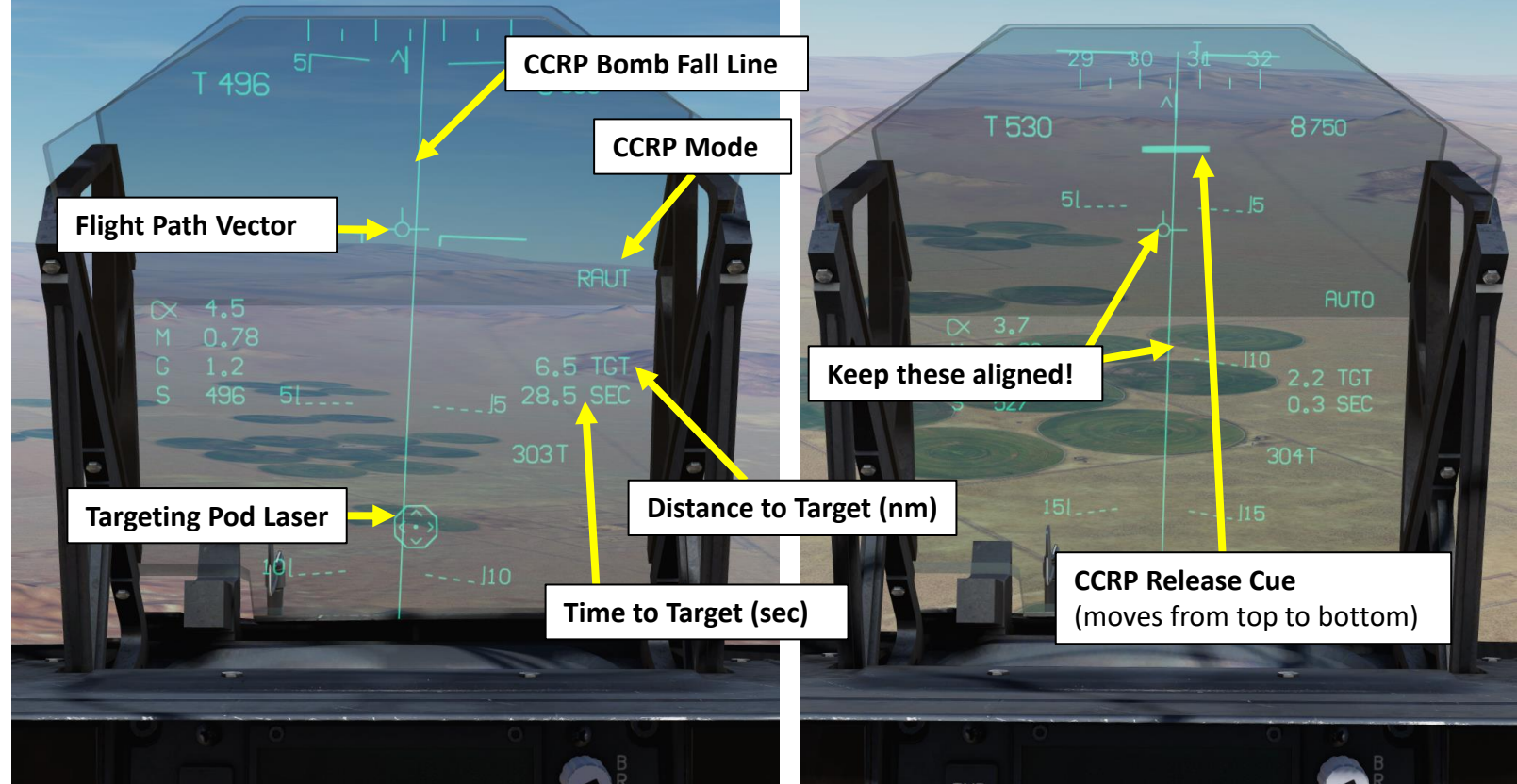

WP Increment Button 21

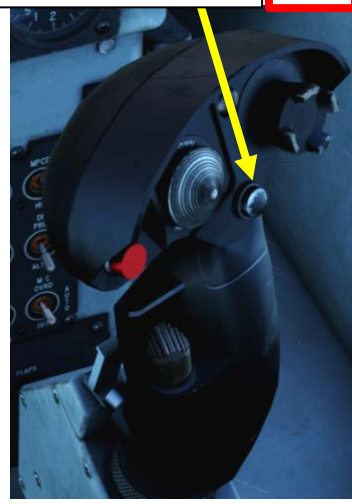

## 2.4 – GAU-12 GUN POD (AIR-TO-GROUND)

1. Set HUD Master Mode to A/G (Air-to-Ground)
2. Go in MPCD main MENU
3. Select STRS (Stores) Page
4. Select Gun Pod with the upper OSB.
5. Set Master Arm switch ON (UP)
6. Start a 45-degree descent towards the target
7. Set pipper on target and wait for the pipper to unwind.
8. You will be within firing range once the pipper starts unwinding
9. Press the Trigger (Fire Gun - SPACE) button to fire gun.
10. Keep in mind that the gun pod is located to the left and will induce a yaw moment when firing. You will have to compensate it with your rudder.

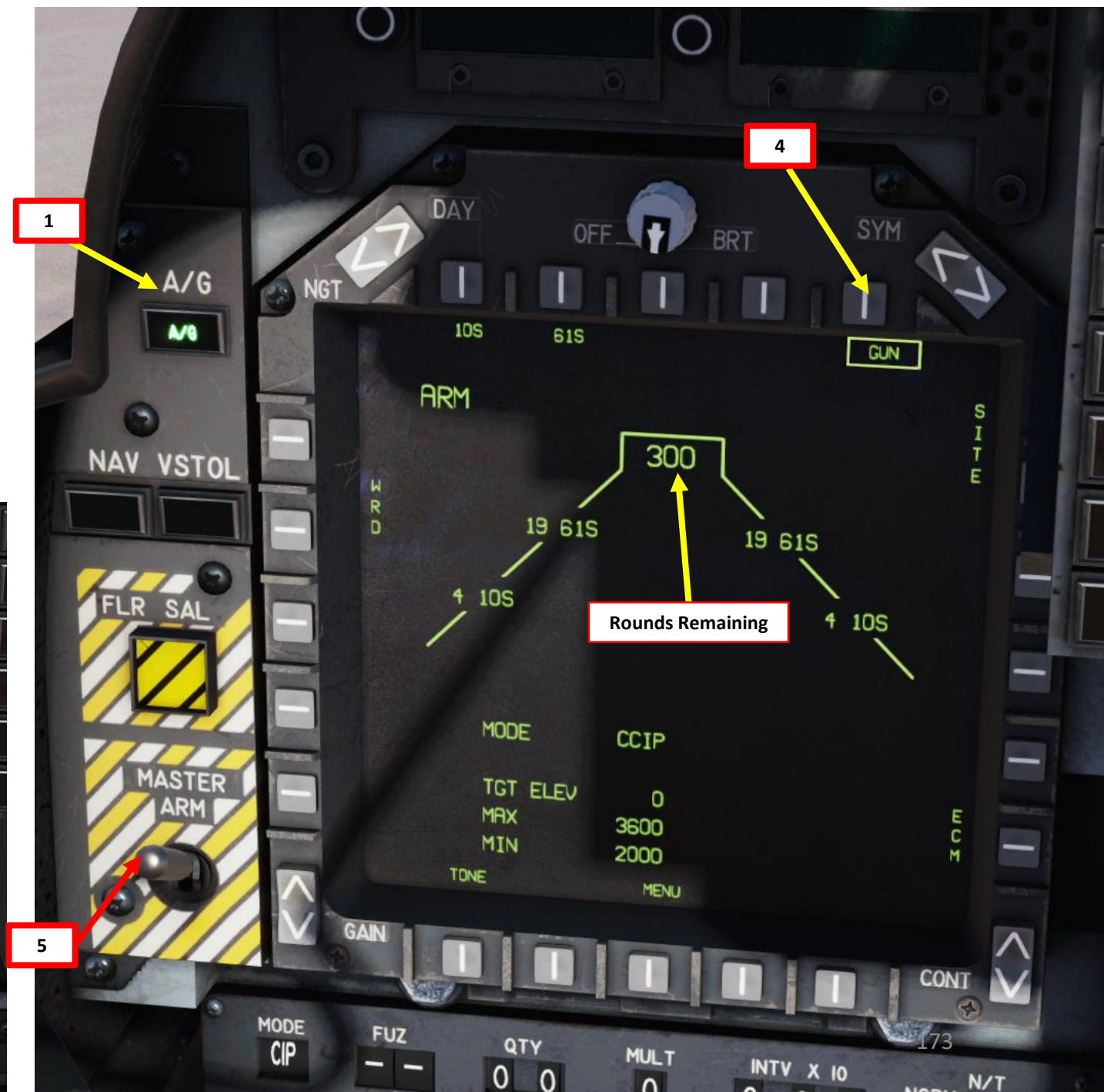
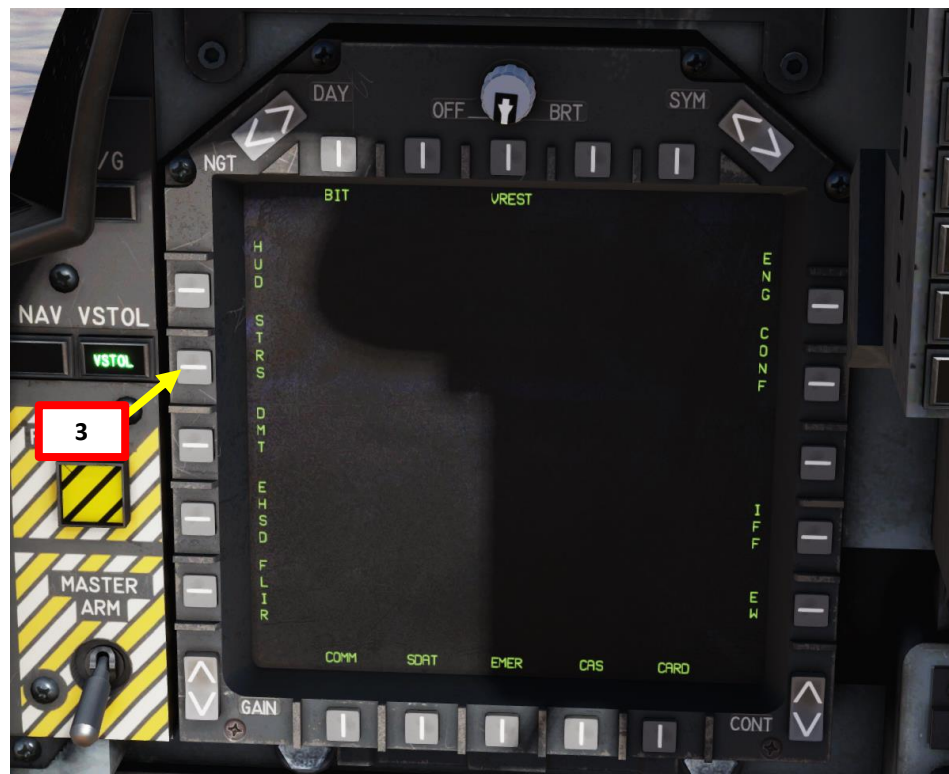

2.4 - GAU-12 GUN POD (AIR-TO-GROUND)

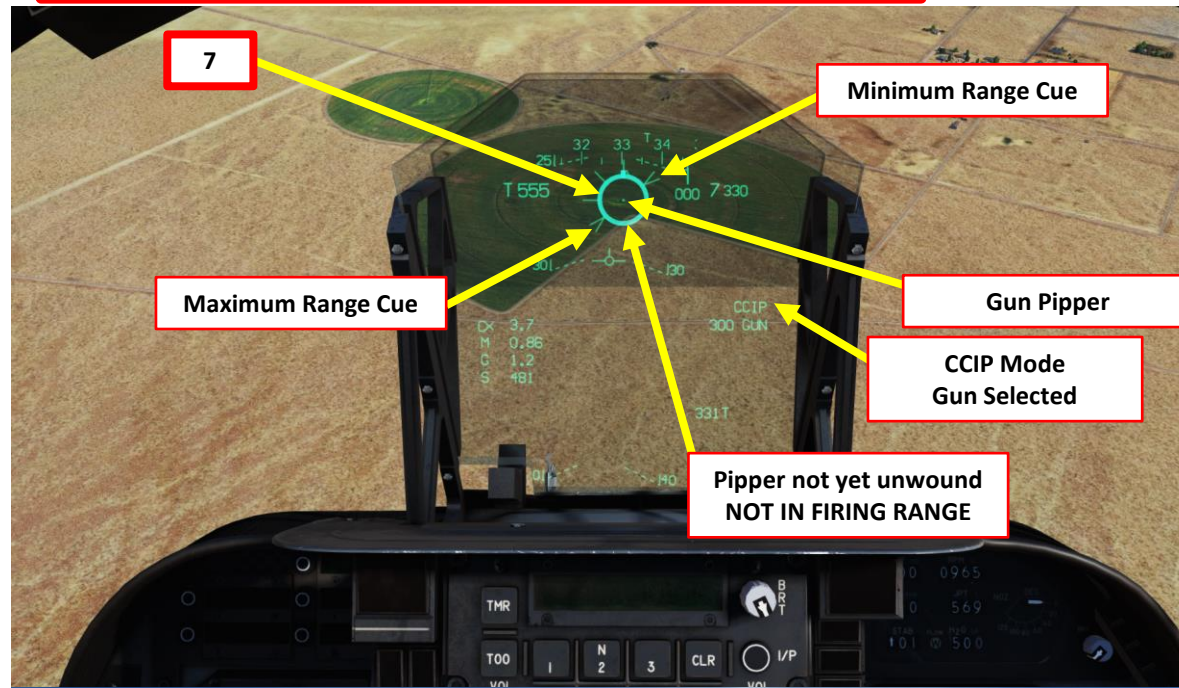

## 2.5 - ROCKETS (+ GAU12 GUN POD)

1. Set HUD Master Mode to A/G (Air-to-Ground)
2. Go in MPCD main MENU
3. Select STRS (Stores) Page
4. Select desired Ground Rockets by either selecting them with the upper OSB (Option Select Button) or by pressing the pylon SEL buttons on the ACP (Armament Control Panel).
5. Set desired Rocket Quantity (number of rockets fired per pod per trigger press)
6. Set Multiple parameter to the number of pylons used.
7. Select Gun Pod with the upper OSB. You will be able to use it in addition to rockets. This step is optional.
8. Set Master Arm switch ON (UP)
9. Start a 45-degree descent towards the target
10. Set piper on target and wait for the piper to unwind.
11. You will be within firing range once the piper starts unwinding
12. Press the Bomb Pickle button (RALT+SPACE) to fire rockets.
13. Press the Trigger (Fire Gun - SPACE) button to fire gun on the gun piper cross.

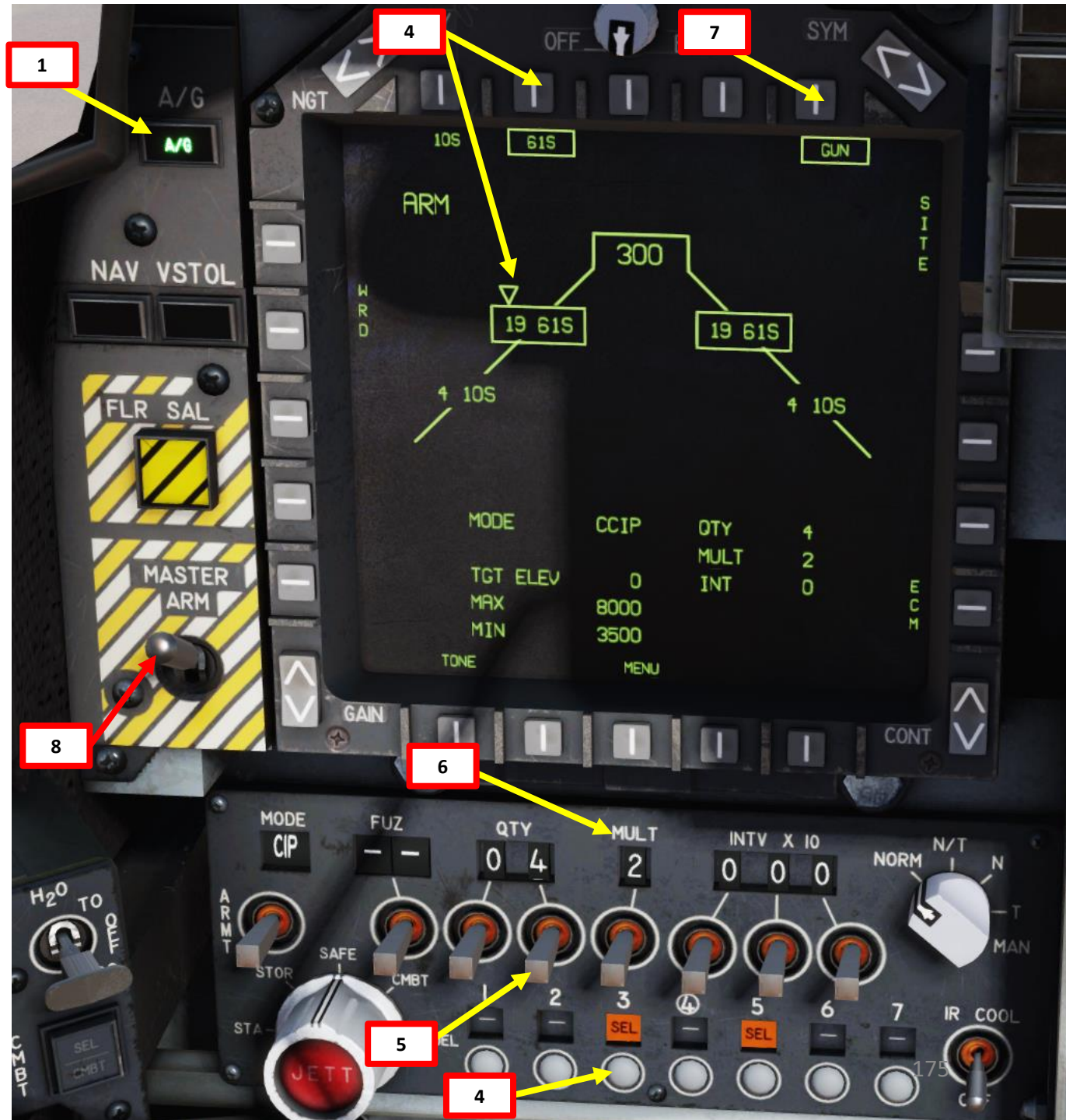

2.5 - ROCKETS (+ GAU12 GUN POD)

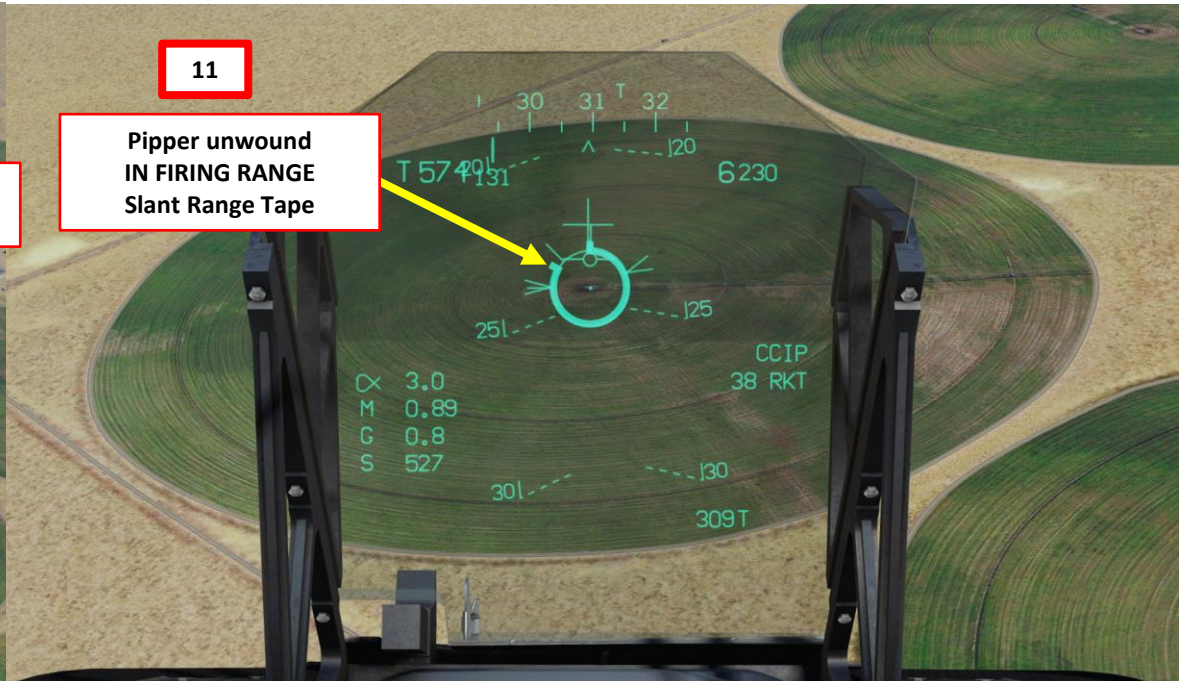
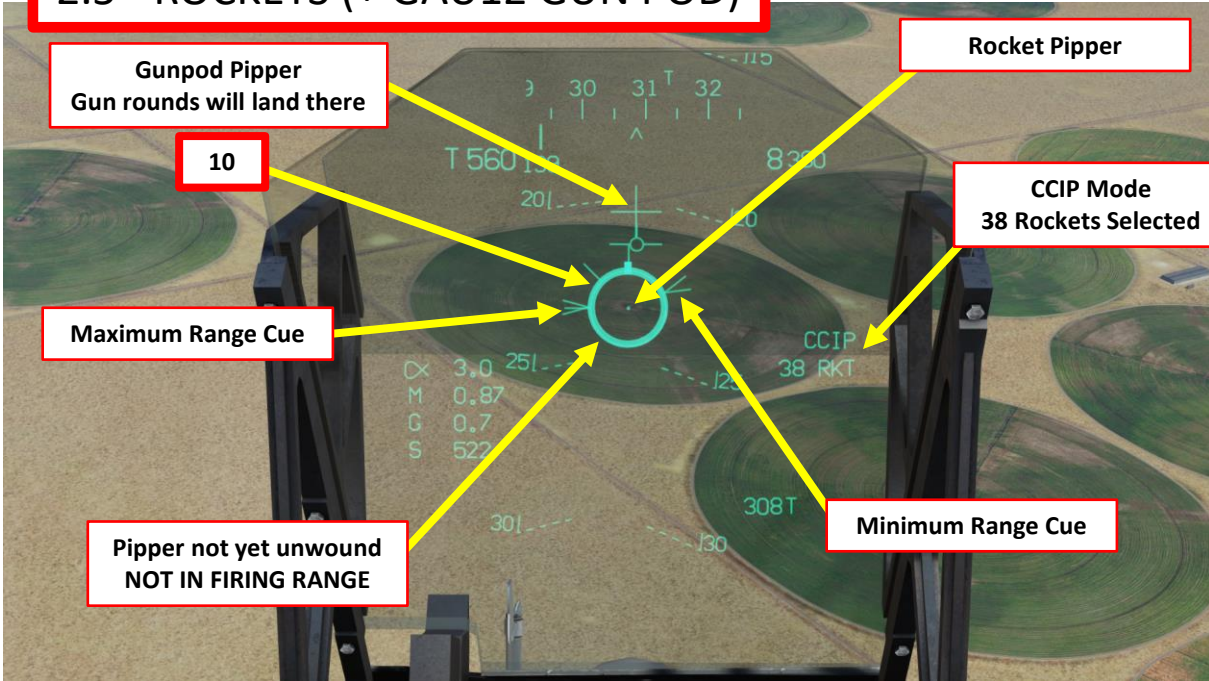

## 2.6 - AGM-122 SIDEARM AIR-TO-SURFACE ANTI-RADIATION MISSILE

1. Set HUD Master Mode to A/G (Air-to-Ground)
2. Set the EW (Electronic Warfare) page on one of your MPCDs, and the STRS (Stores) page on the other MPCD.
3. For SEAD (Suppression of Enemy Air Defenses) missions, I suggest that you make sure your RWR (Radar Warning Receiver) is set to ON, your EXP (Expendable) countermeasures are set to AUTO and your ECM (Electronic Countermeasures) switch is set in the appropriate position if a DECM pod is equipped.
4. Click on the SEL buttons to select your Sidearm missiles (SA)
5. Set Master Arm switch – ON (UP)
6. Find radar emitters using the RWR on the EW page and on your HUD.
7. The Sidearm seeker is more sensitive when it is uncaged, therefore, if the seeker does not give a good tone when it is pointed at the threat, uncaging the missile will increase seeker sensitivity. It is **not** necessary for the missile to be uncaged to fire.
8. If desired, press the CAGE/UNCAGE button to uncage the Sidearm
9. When the low-pitch tone switches to a high-pitch tone and your seeker reticle locks onto the source of radiation emission, your Sidearm has locked on the target.
10. Press the Trigger (Fire Gun - SPACE) button to fire Sidearm missile

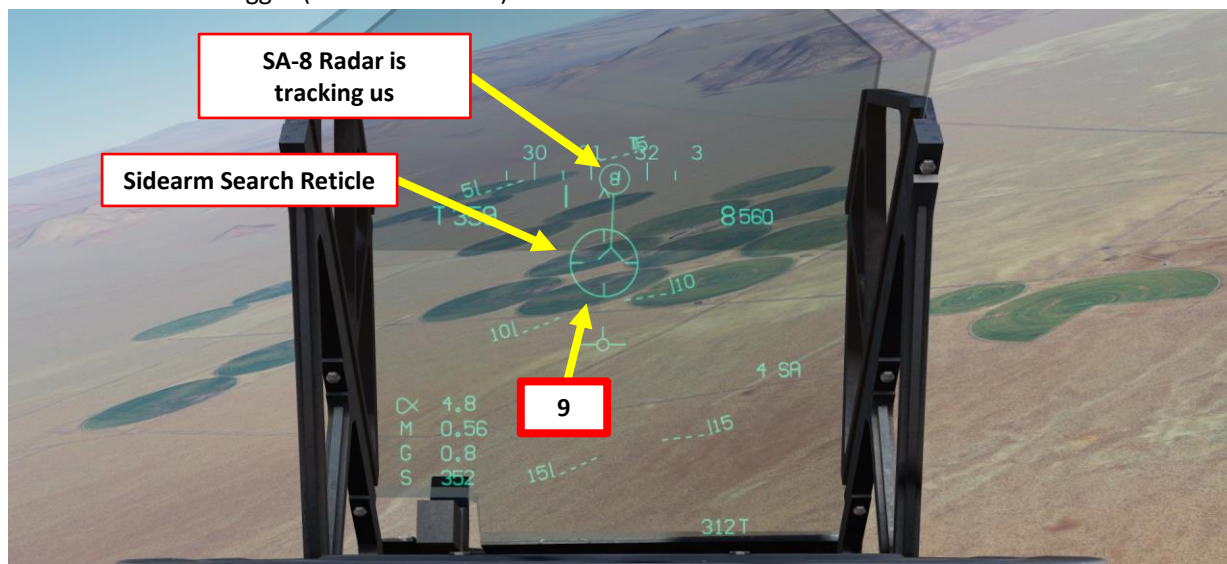
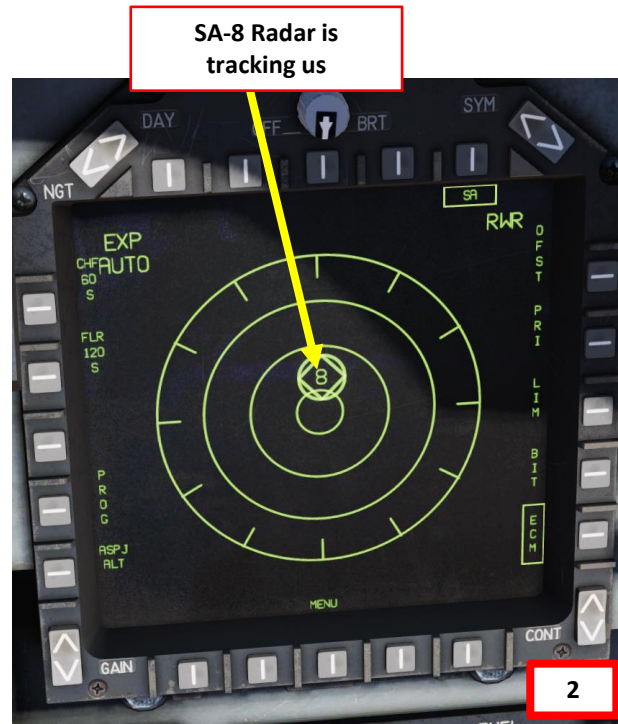

2.6 - AGM-122 SIDEARM  
AIR-TO-SURFACE ANTI-RADIATION MISSILE



## 2.7 - AGM-65F/G MAVERICK (IRMV) AIR-TO-GROUND MISSILE

1. Set HUD Master Mode to A/G (Air-to-Ground)
2. You should prepare your Maverick missiles as soon as possible. Cooldown and preparation take a while.
3. Go in MPCD main MENU
4. Select STRS (Stores) Page
5. Select IRMV (Infrared Maverick) missile by either selecting them with the upper OSB (Option Select Button) or by pressing the pylon SEL buttons on the ACP (Armament Control Panel).
6. As soon as the Maverick missile is selected, it will begin its cooldown phase, which will last 3 minutes. STBY indicates the cooldown phase in progress, while RDY indicates that the Maverick is warmed-up and ready for use.
7. Set Master Arm Switch - ON (UP) and set FUZ (fusing) switch to either IN, D1 or D2.

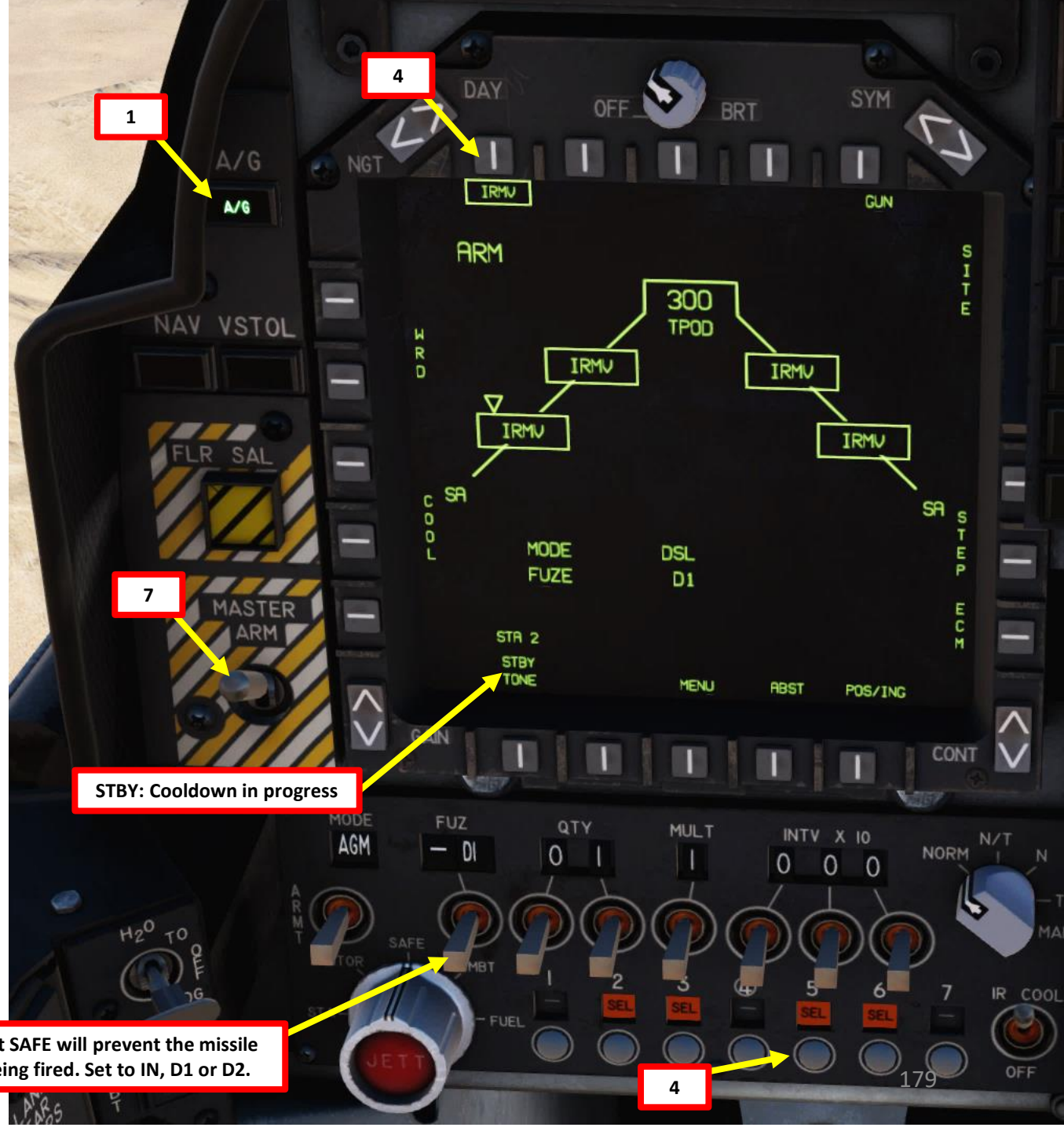
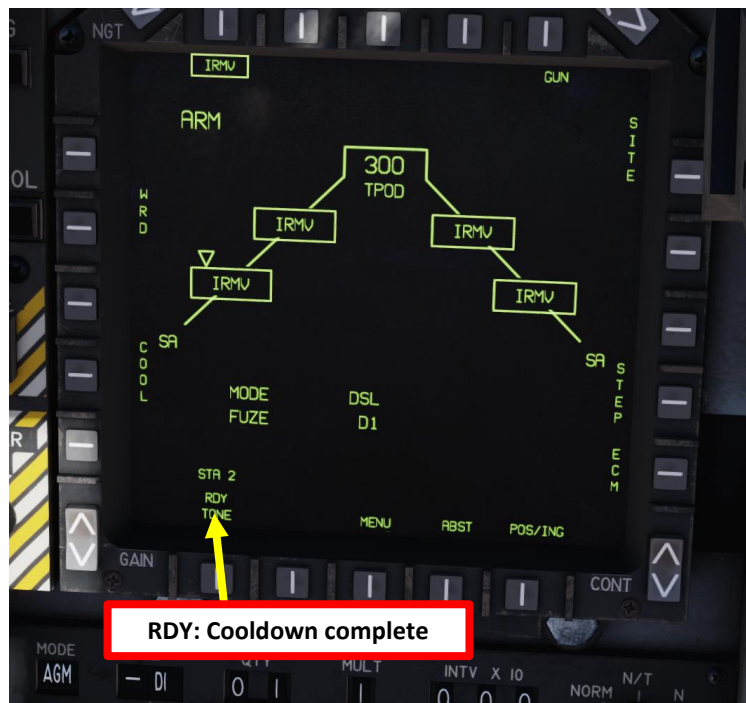

## 2.7 - AGM-65F/G MAVERICK (IRMV) AIR-TO-GROUND MISSILE

*The steps on this page are optional.*

8. Set DMT (Dual Mode Tracker) Power Switch ON (UP)
9. Press the Sensor Select Switch AFT twice to toggle LST/TV Mode of the DMT to TV. DMT feed will appear on your MPCD displays.
10. At first, TV Mode tracks your aircraft's flight path vector (where your nose is pointing).
11. Press the « TDC DOWN Action Position » button to slave the DMT to a designated target.
12. Once target is designated, you can slew the DMT more precisely using the TDC LEFT/RIGHT/FORWARD/AFT controls. You will be tracking the ground, NOT the target.

**Note:**

Steps 8 through 12 are optional. You can simply skip to step 13 and uncage the Maverick and find your target using the IRMV sensor, which is independent from the DMT. In other words, you do not absolutely need the DMT to use the Maverick. It is simply a way to have a better view of the target with the DMT TV.



**TDC (Target Designation Caret) Control Switch**  
LEFT/RIGHT/FORWARD/AFT/DOWN (ACTION)

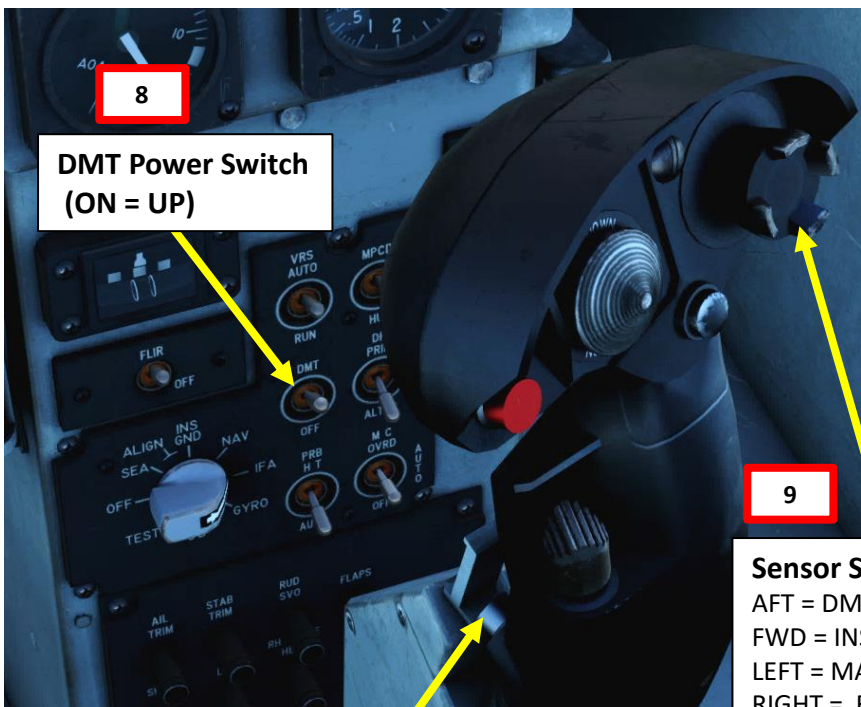

8

**DMT Power Switch**  
(ON = UP)

9

**Sensor Select Switch**  
AFT = DMT: LST/TV  
FWD = INS: IRMV/EOMV  
LEFT = MAP Center/Decenter  
RIGHT = FLIR/HUD-BH/WH  
DOWN (PUSHED) = HUD Scene Reject/TPOD

**AG Target Undesignate/NWS/FOV Toggle Switch**

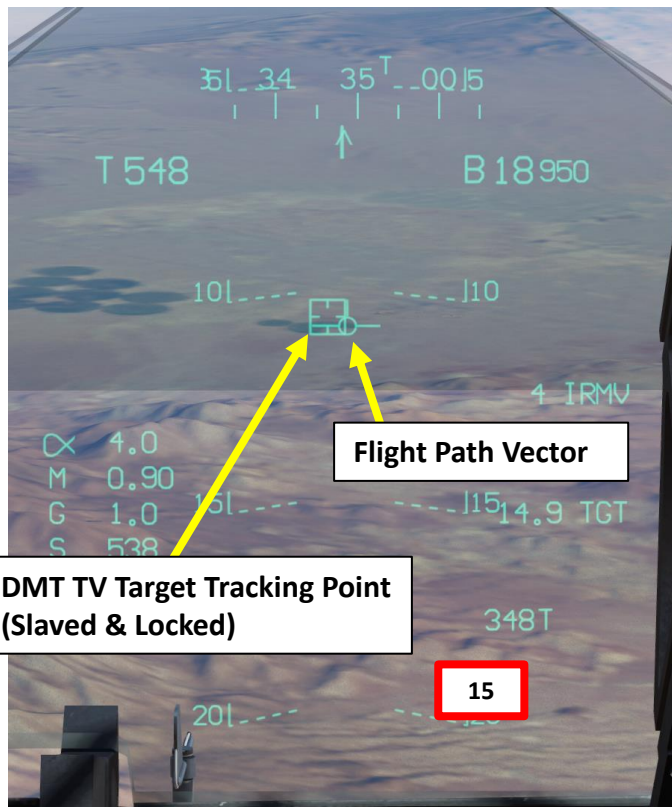

**Flight Path Vector**

**DMT TV Target Tracking Point**  
(Slaved & Locked)

15



9

**Slew the marker over the target**

## 2.7 - AGM-65F/G MAVERICK (IRMV) AIR-TO-GROUND MISSILE

13. Press the CAGE/UNCAGE button to uncage the Maverick.
14. Press the Sensor Select Switch FWD (INS: IRMV/EOMV) to select the IRMV feed
15. Press the OSB next to FOV to narrow the field of view.
16. Periodically press the TDC DOWN (ACTION) button to acquire a lock on the target. The Maverick is most likely going to acquire a good lock from a distance of 7.5 miles.
17. When lock is acquired by Maverick, press the Bomb Pickle button (RALT+SPACE)



**TDC (Target Designation Caret) Control Switch**  
LEFT/RIGHT/FORWARD/AFT/DOWN (ACTION)

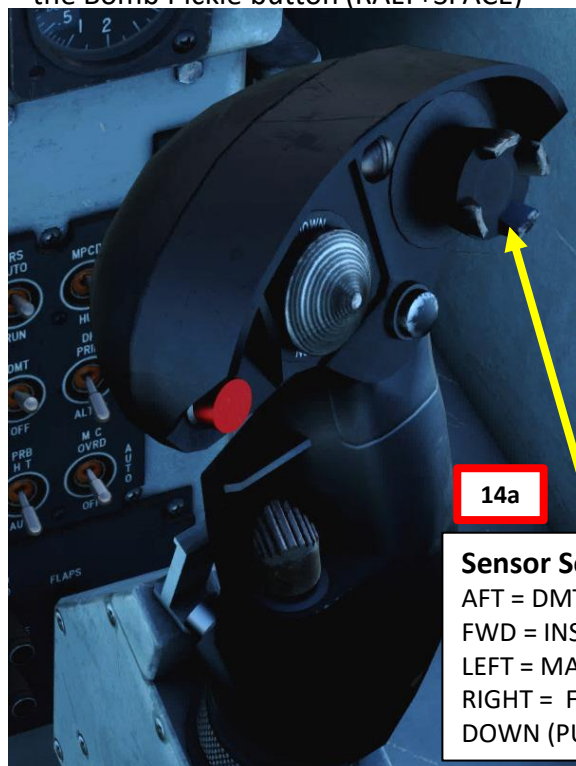
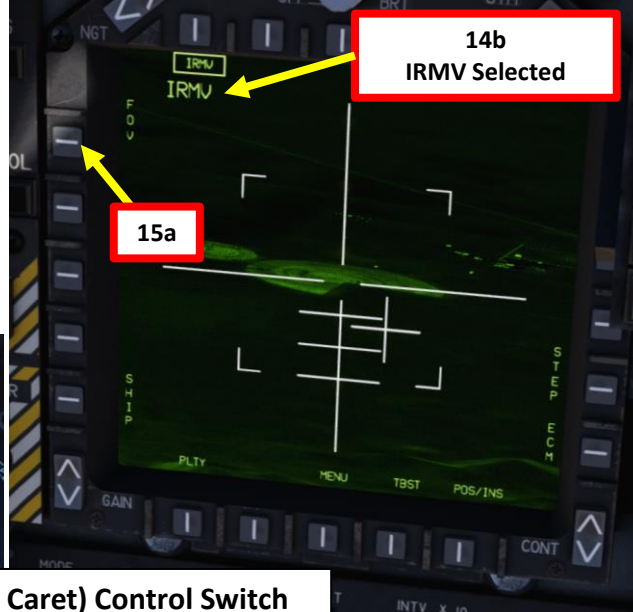

**Sensor Select Switch**  
AFT = DMT: LST/TV  
FWD = INS: IRMV/EOMV  
LEFT = MAP Center/Decenter  
RIGHT = FLIR/HUD-BH/WH  
DOWN (PUSHED) = HUD Scene Reject/TPOD



**Weapon Cage/Uncage Switch**

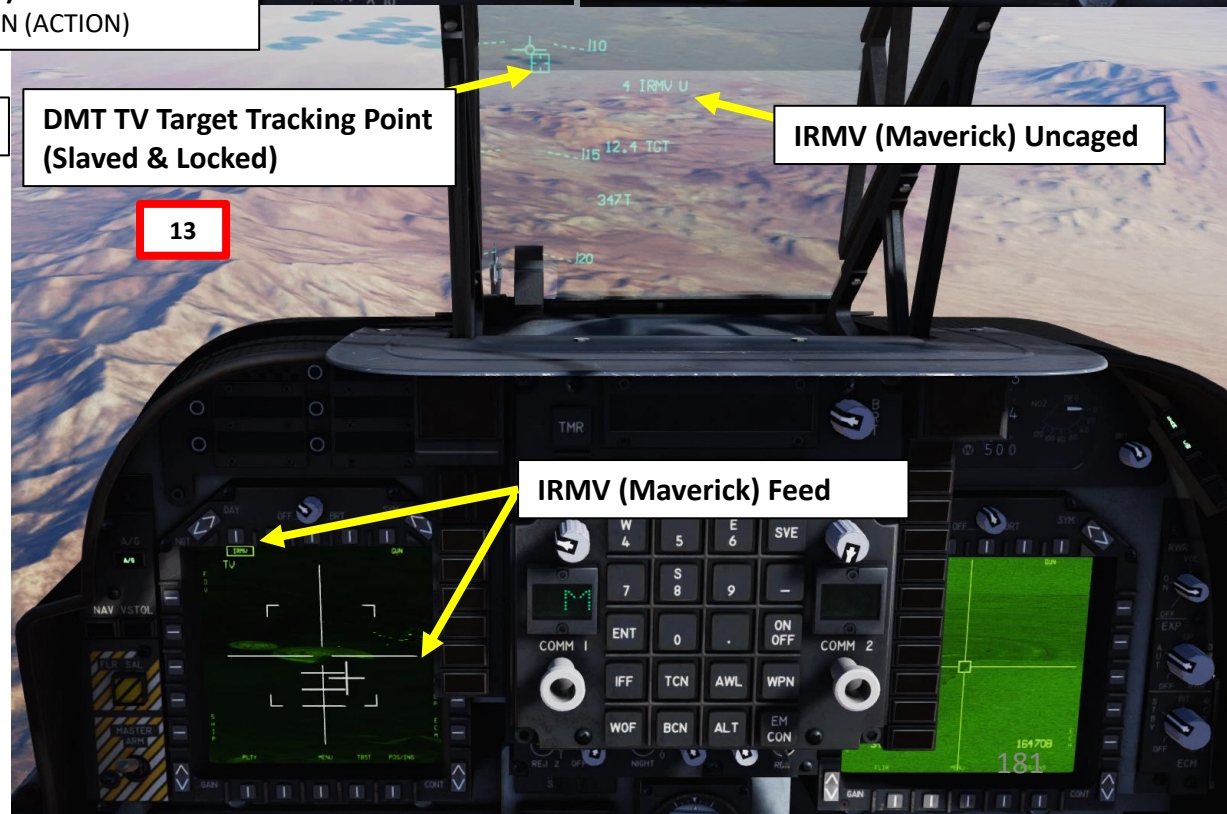

**DMT TV Target Tracking Point (Slaved & Locked)**

**IRMV (Maverick) Uncaged**

**IRMV (Maverick) Feed**

2.7 - AGM-65F/G MAVERICK (IRMV)  
AIR-TO-GROUND MISSILE

**Note:** IR Mavericks have a Gimbal Limit warning. If the gimbal limits are reached, a "GIMBAL LIMITS" warning will flash on the MPCD screen and then the missile's seeker will cage itself. You will have to uncage the missile again. If you attempt to uncage while the seeker is at gimbal limits, the warning will appear and the missile will cage itself again. Gimbal Limits may be reached when the missile is slaved to the DMT.

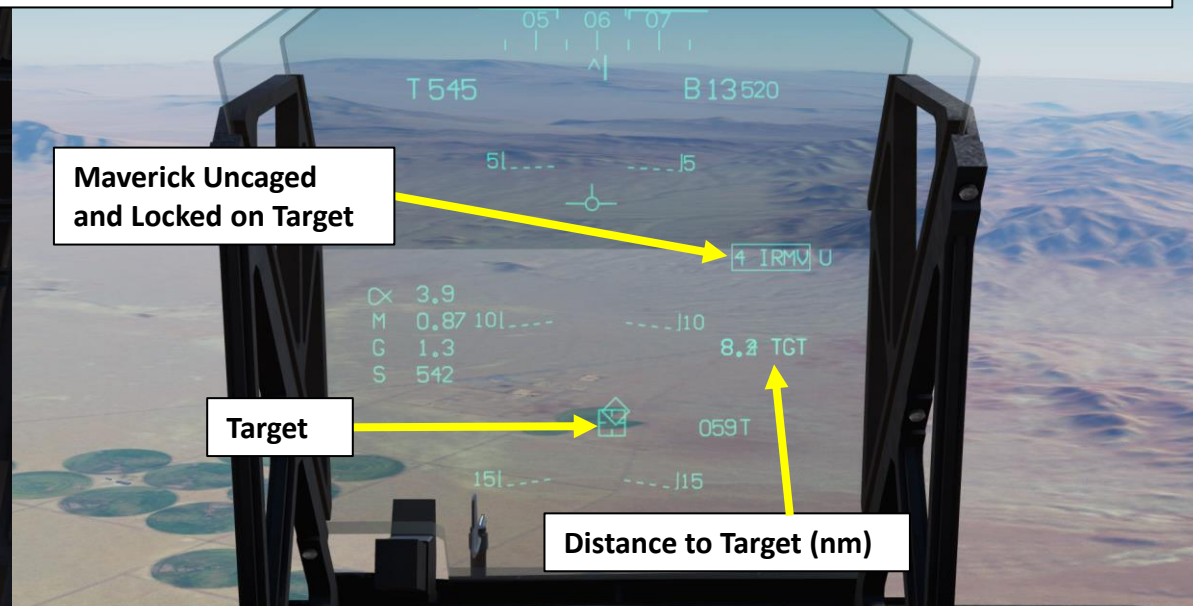

## 2.8 - AGM-65E MAVERICK (LMAV) AIR-TO-GROUND MISSILE

Note: We will have to use a Targeting Pod (TPOD) to obtain a laser for the LMAV Maverick to track.

1. Set HUD Master Mode to A/G (Air-to-Ground)
2. Go in MPCD main MENU
3. Select STRS (Stores) Page
4. Select LMAV (Laser-Guided Maverick) missile by either selecting them with the upper OSB (Option Select Button) or by pressing the pylon SEL buttons on the ACP (Armament Control Panel).
5. As soon as the Maverick missile is selected, the CAGED maverick page will appear with its laser code.
6. Set Master Arm Switch - ON (UP) and set FUZ (fusing) switch to IN

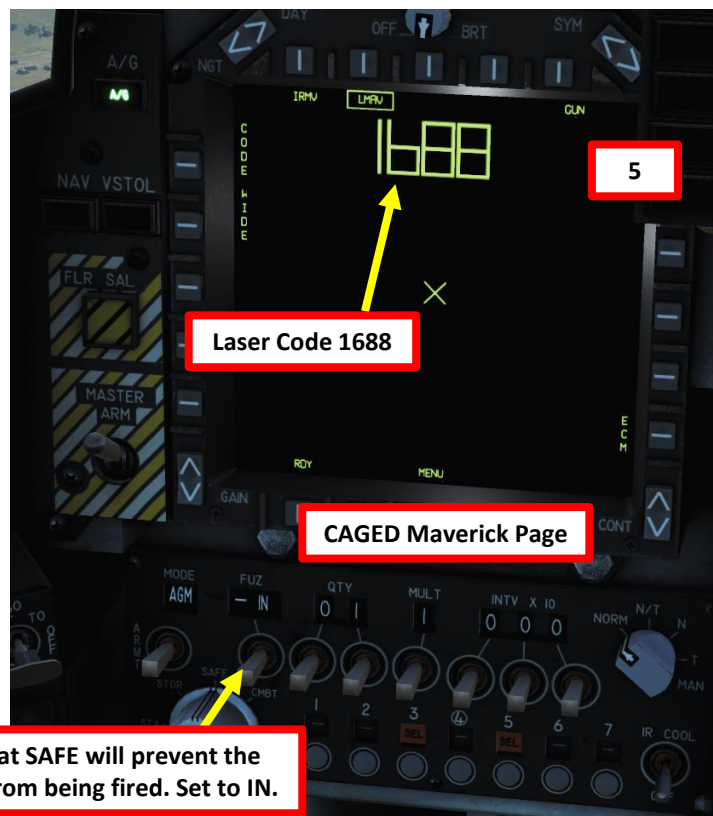

## 2.8 - AGM-65E MAVERICK (LMAV) AIR-TO-GROUND MISSILE

7. Set laser code to 1688: Go in EHSI page, press the OSB (Option Select Button) next to CODE (should be boxed), then set required laser code on the keypad (standard code is **1688**), then press ENT. Unbox CODE by pressing OSB again. Default laser code **1111** is an initialization code **and will not work**.
8. Power up the Targeting Pod:
  - a) Click on the OSB next to the "TPOD" page in the main MPCD MENU
  - b) Clicking the OSB next to STBY
  - c) The Targeting Pod will start its initialization for 3 minutes.
  - d) After initialization, the pod starts FLIR cooling, which takes approximately 6 to 8 minutes. Pod will display F-NOTRDY (FLIR Not Ready) indication when FLIR cooling is incomplete.
9. In order to use the TDC (Target Designation Caret), press the Sensor Select Switch DOWN twice to use TPOD Mode.
10. Slew your TDC using the TDC LEFT/RIGHT/FWD/AFT controls.
11. Press the « TDC DOWN Action Position » button to designate a target. Press the Sensor Select Switch AFT short to toggle between area track (AR) and point track (PT).
12. Select desired Laser Options (LASR)
13. Arm Laser (ARMED)
14. Fire Laser to lock targeting pod on target and lase it.

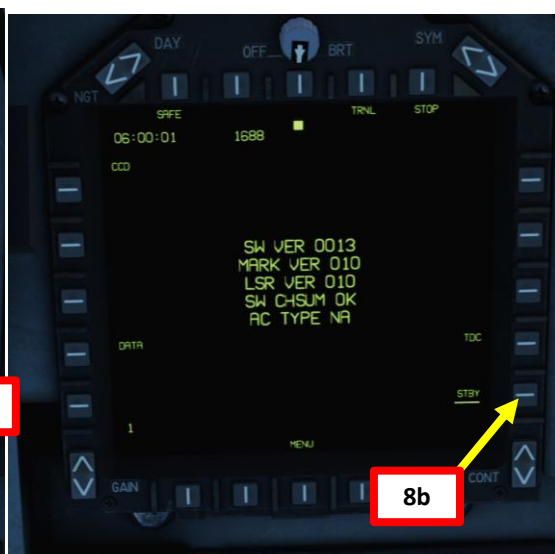
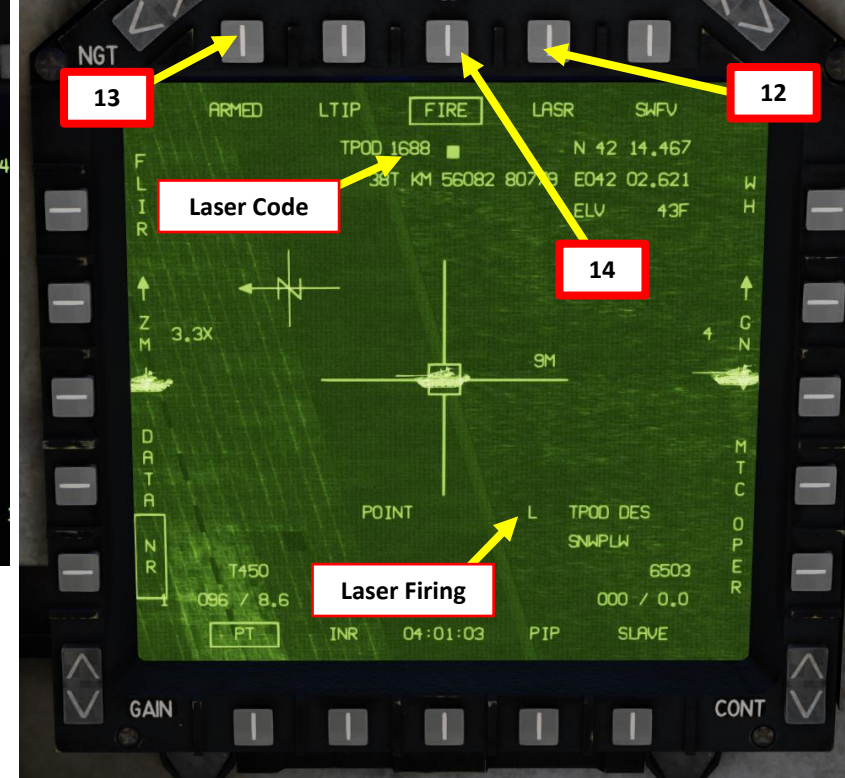
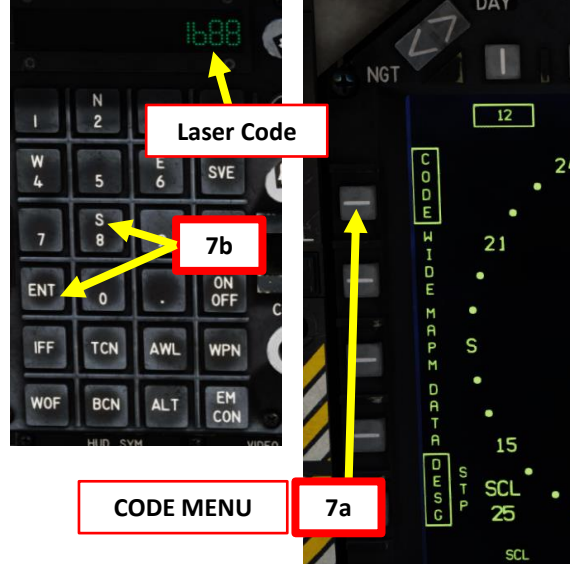

TDC (Target Designation Caret) Control Switch  
LEFT/RIGHT/FORWARD/AFT/DOWN (ACTION)

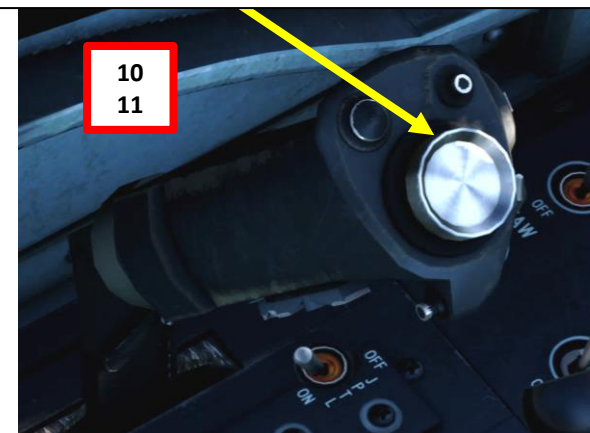

## 2.8 - AGM-65E MAVERICK (LMAV) AIR-TO-GROUND MISSILE

15. Press the CAGE/UNCAGE button to uncage the Maverick.
16. The seeker head will automatically scan for the laser.
17. Once the Maverick seeker has found the laser and you are in range to fire, the Maverick feed will be filled with a full square and "INRNG" (In Range) will appear on the HUD. A diamond will appear over the target.
18. When lock is acquired by Maverick, press the Bomb Pickle button (RALT+SPACE)

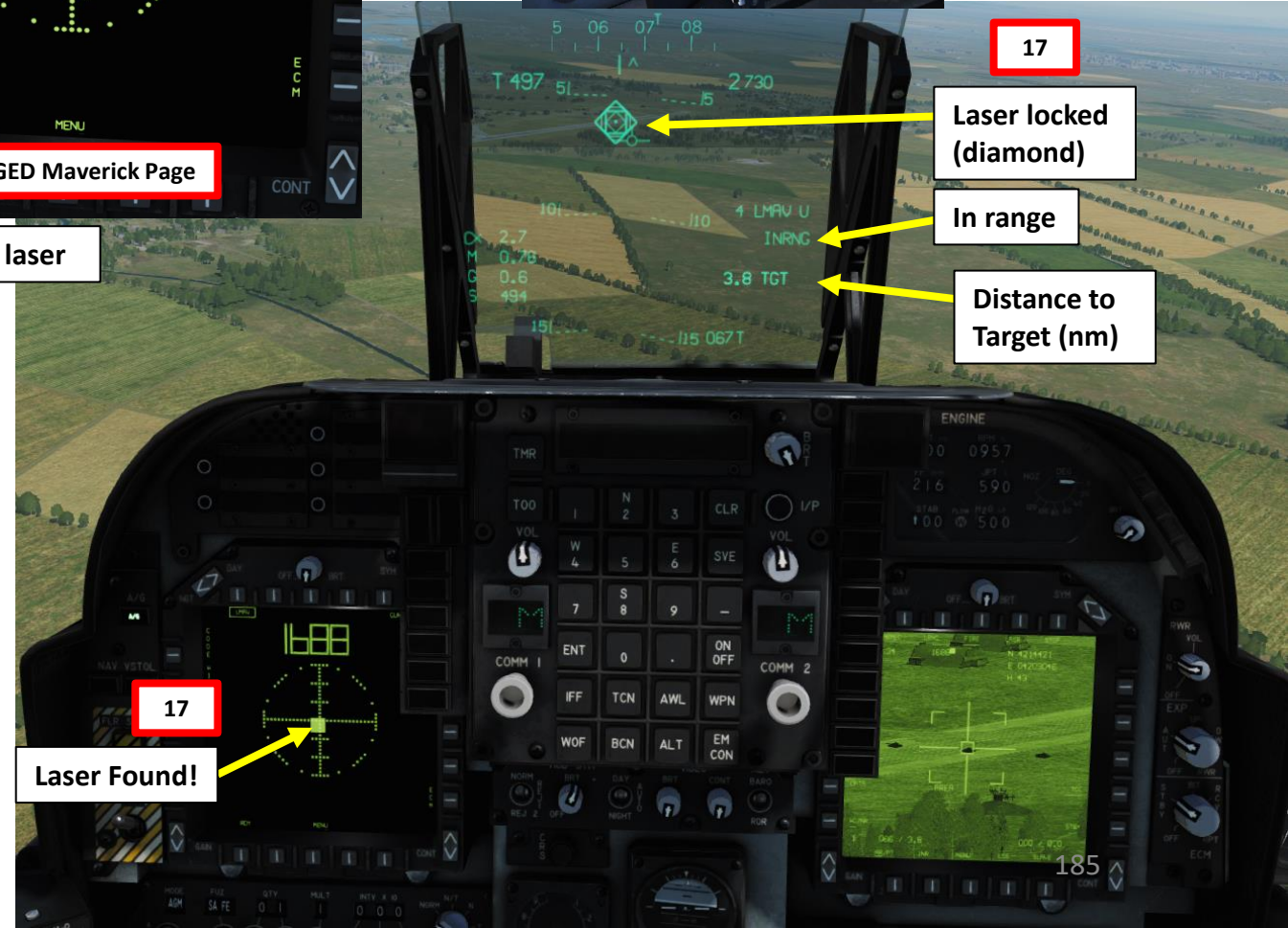
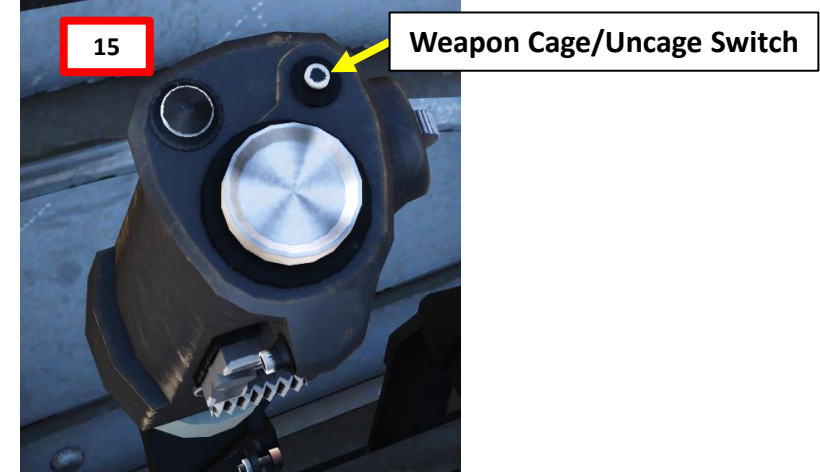

2.8 - AGM-65E MAVERICK (LMAV)  
AIR-TO-GROUND MISSILE



## 2.9 - GBU-38 JDAM INTRODUCTION

The JDAM (Joint Direct Attack Munition ) is a guidance kit that converts unguided bombs into all-weather precision-guided munitions. JDAM equipped bombs are guided by an integrated inertial guidance system coupled to a GPS receiver, giving them a published range of up to 15 nm (28 km).

The JDAM used by the Harrier is employed slightly differently than on other aircraft like the Hornet. There are two primary methods of using the JDAM:



### **METHOD 1: Absolute Release (Pre-Planned)**

Absolute Release is the primary mode of operation. It is used against preplanned targets that were loaded into the aircraft along with the mission flight plan. They are present in the flight plan as Targetpoints 1 to 4. It is the most accurate mode since the target position is precisely positioned in relation to the world. In real life, the Forward Air Controller (FAC) sends close air support mission data through the ATHS (Automatic Target Handoff System), which relays information to the AV-8B Harrier itself.

In other words, The **ATHS** provides a digital communication link between a Forward Air Controller and the AV-8B. The system is capable of communicating with US Army, USAF and USMC FACs and AOs. Received data is displayed in USMC format. In the DCS version, it is the only way to insert target information into the flight plan's Targetpoints 1 to 4. These Targetpoints are set via the F10 map.

### **METHOD 2: Relative Release (TOO, Target-of-Opportunity)**

Relative Release mode is used whenever the target is designated by using the aircraft's onboard sensors (DMT, INS, **Targeting Pod**). It is the least accurate mode since the target position is determined in relation to the aircraft's own position. It is highly recommended that you use a targeting pod for this since laser ranging is required for TOO mode.

## 2.9 - GBU-38 JDAM INTRODUCTION

**Information in red** is entered by the FAC using a special transmitter. Currently the device cannot be reliably simulated in DCS so they are not used.

The **Close Air Support (CAS) MPCD Display** is used to show all available targets entered by loading the F10 Map markers.

### Record Data

1. **IP:** Initial Point Name
2. **BRG:** Bearing to target from the IP. If no IP exists, it is calculated from the aircraft.  
**POSB:** Bearing to target from aircraft current position.
3. **RNG:** Range to target (nm) from the IP. If no IIP, it is calculated from aircraft position.  
**POSR:** Range to target (nm) from aircraft current position.
4. **ELEV:** Target ground elevation (ft)
5. **DESC:** Target shorthand description
6. **L/L:** Target Latitude/Longitude Coordinates
7. **MARK:** Indicates if target is being marked
8. **FRND:** Friendly forces position (Direction & Range)
9. **EGRS:** Egress route from target
13. **RMKS:** Any notes, remarks or observations about the target.
14. **TOT:** Time-On-Target  
**RTIME:** Aircraft real time.

**Up Arrow:** Moves to previous record  
**Down Arrow:** Moves to next record

- **USE Button:** Sets the UFC for target data transfer to a Targetpoint.
- **RCALL Button:** Recalls/Displays the list of available targets
- **MENU Button:** Displays the main MPCD page
- **CAS Button:** Displays the CAS (Close Air Support) data page.

**Record Identification Number**  
Internal DCS ID for the F10 Map marker.

### ACTIVE Label

Appears next to the Record Number value if the record information has been loaded into a Targetpoint.

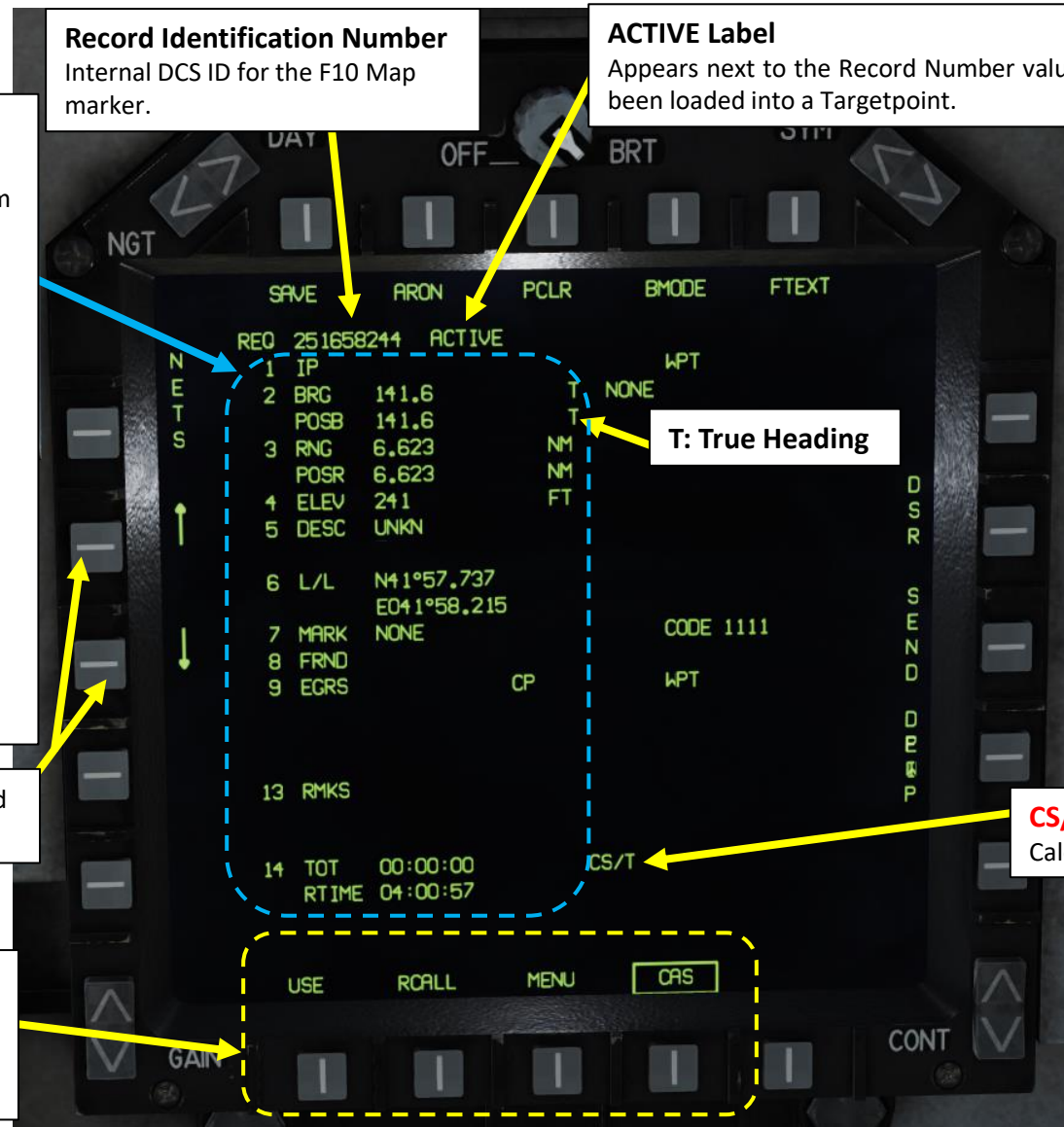

**T: True Heading**

**CS/T:** Command Speed/Time.  
Calculated based on TOT.

## 2.9 - GBU-38 JDAM INTRODUCTION

The **RCALL (Recall) Display** of the CAS page shows a list of all targets available for use with the INS Targetpoint. Only a maximum number of 18 records can be loaded.

**Record Identification Number**  
Internal DCS ID for the F10 Map marker.

**Record Type**  
CAS: Close Air Support

**Record Number**  
Record for F10 map markers from 1 to 18.

**Asterisk \*:** Indicates which one is the active record in the CAS page

**Up Arrow:** Moves to previous record  
**Down Arrow:** Moves to next record

**RCALL Indication (Boxed):** RCALL (Recall) page is selected

**UTM:** Target Position in UTM (Universal Transverse Mercator) Coordinates

**TIME:** Local Mission Time when the F10 Map marker was created

**Targetpoint**  
**T2:** Targetpoint where the target record has been uploaded. Targetpoints go from T1 to T4.

**Targetpoint**  
**T43:** Targetpoint where the target record has been uploaded. Targetpoints go from T1 to T4. If a record has been uploaded to two or more targetpoints the indexes will be concatenated (i.e.: T43, indicating targetpoints 4 and 3).

**MENU Button:** Displays the main MPCD page

**CAS Button:** Displays the CAS (Close Air Support) data page.

REQ#	Record Type	Record ID	UTM	TIME	Targetpoint
1	CAS	251658242	37T GG 4239656521	08:00:00,0	T2
2	CAS	251658243	37T GG 4841253045	08:00:00,0	
* 3	CAS	251658244	37T GG 4614649857	08:00:00,0	T43
4	CAS	251658245	37T GG 4276847503	08:00:00,0	
5	CAS	251658246	37T GG 4386244146	08:00:00,0	
6	CAS				
7	CAS				
8	CAS				
9	CAS				
10	CAS				
11	CAS				
12	CAS				
13	CAS				
14	CAS				
15	CAS				
16	CAS				
17	CAS				
18	CAS				

# 2.9 - GBU-38 JDAM INTRODUCTION

Here is an example of how the CAS and RCALL pages are integrated together.

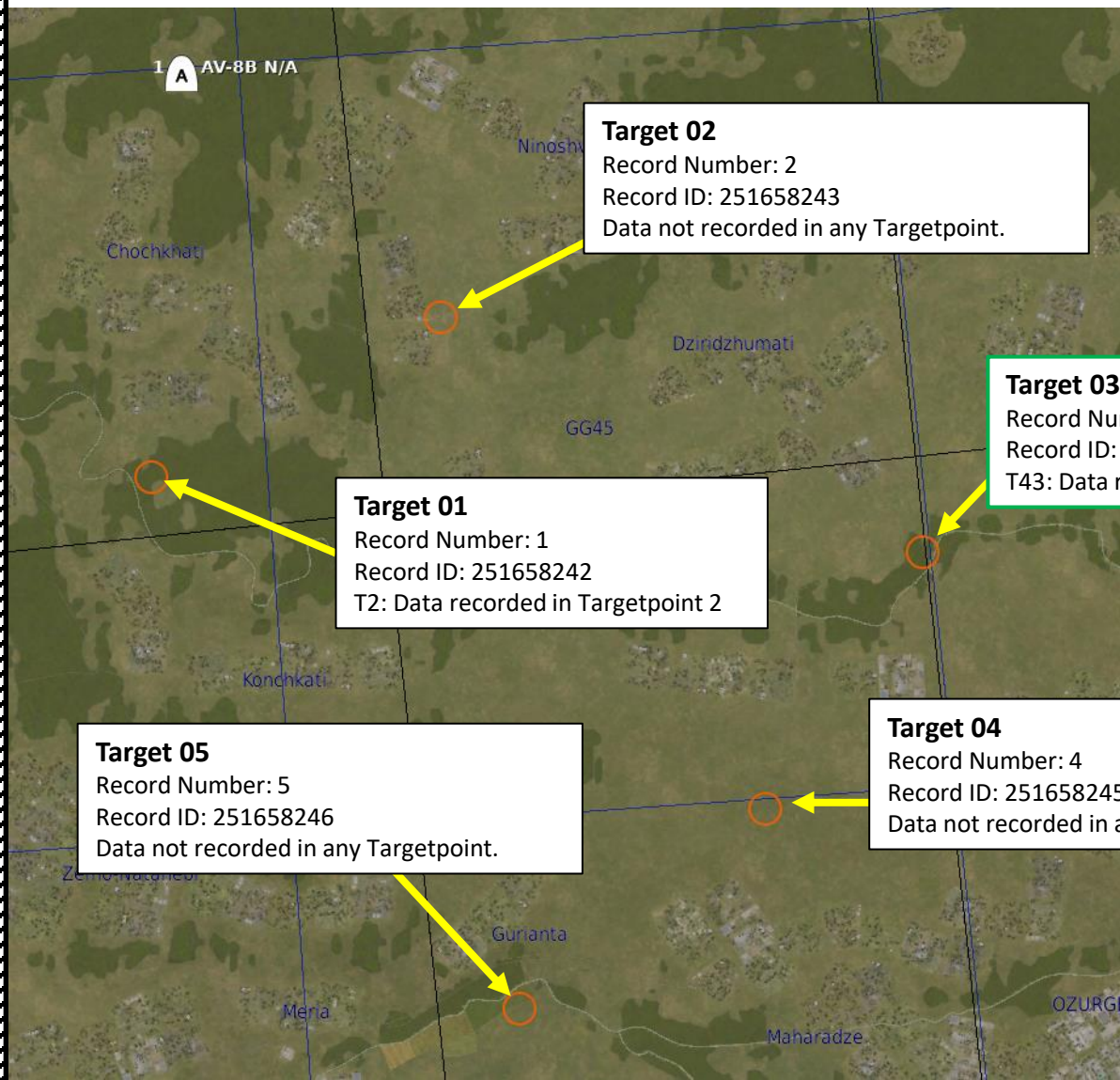

## CAS Page

Selected Record Identification Number: 251658244



## Target 03 (Selected)

Record Number: 3  
Record ID: 251658244  
T43: Data recorded in Targetpoints 4 and 3

## RCALL Page

Selected Record Number: 3  
Selected Record ID: 251658244



Available Targets/Records

## 2.9 - GBU-38 JDAM INTRODUCTION

Here is an overview of the two JDAM employment methods:

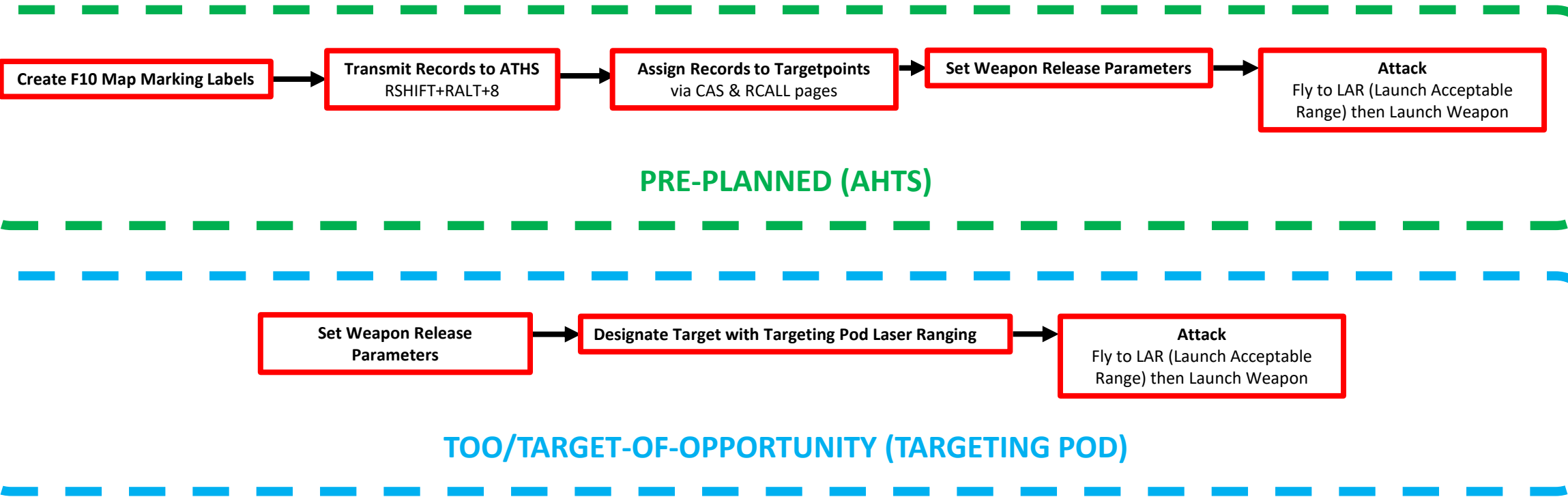

## 2.9.1 - GBU-38 JDAM PRE-PLANNED (ATHS)

### CREATE F10 MAP MARKING LABELS

1. Press F10 to display the map, then select the MARK LABEL button.
2. Click where you want to create a target point, then type "T" followed by the Target number you want to create. "T01" would be "Target 1", "T02" would be "Target 2", etc.

**Note:** As of 27/12/2019, you need to create a throwaway marking label (I called it "T00", but it could be called anything) **before** creating your other marking labels (T01, T02, T03, T04... etc.)

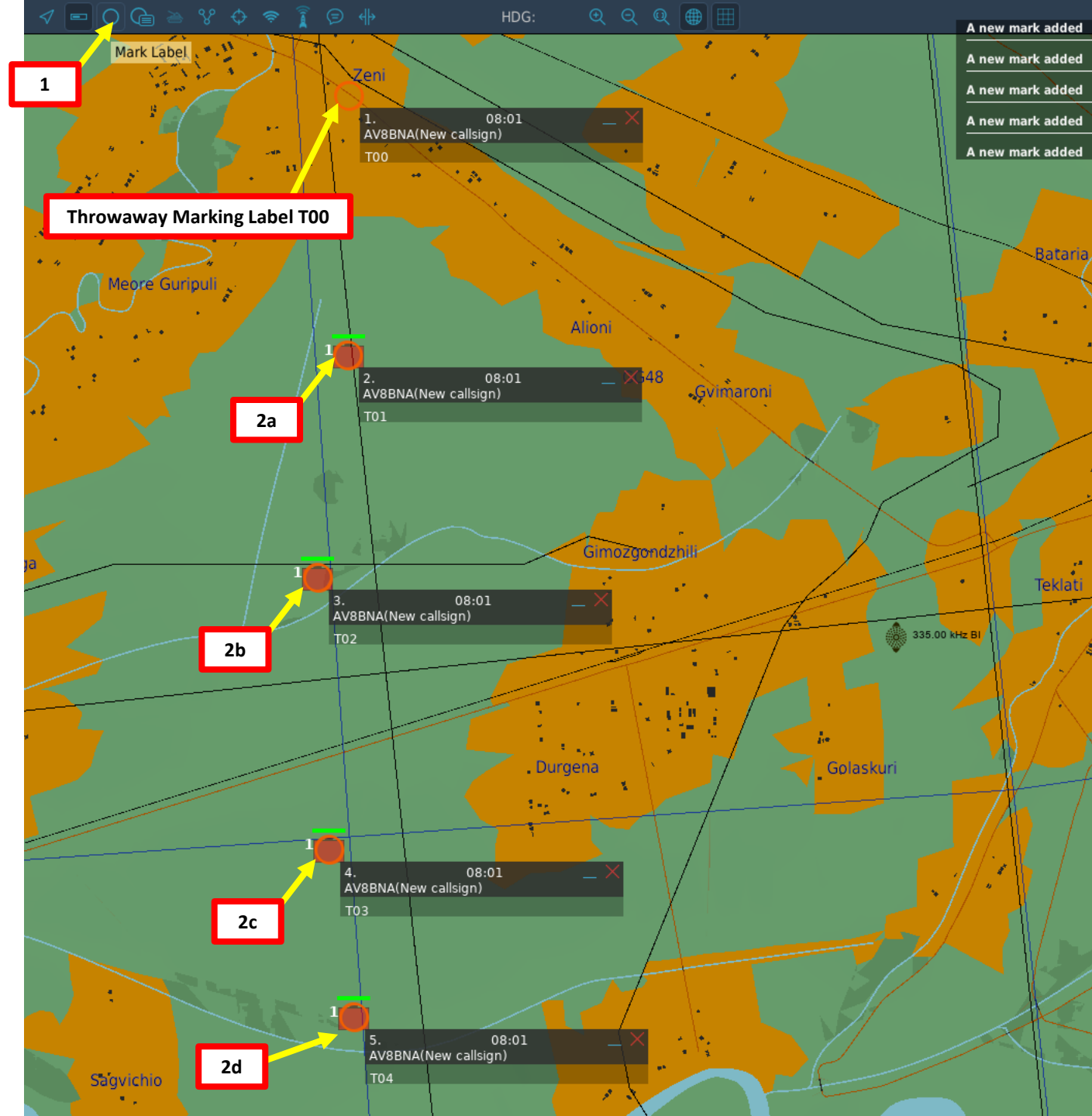

## 2.9.1 - GBU-38 JDAM PRE-PLANNED (ATHS)

### TRANSMIT RECORDS TO ATHS

3. Go in MPCD main MENU
4. Select CAS (Close Air Support) Page. At the moment, there should be no records available yet.
5. Transmit marking label data (records) to the ATHS (Automatic Target Handoff System) by pressing “RSHIFT+RALT+8”. This will simulate a FAC (Forward Air Controller) sending you the records for fire missions.
6. If you perform the previous step while on the ground, records for T01 through T04 will automatically be assigned to Targetpoints 1 through 4. This information will be available through the Kneeboard (RSHIFT+K) on the TARGET LIST page.

However, if the previous step is performed while in the air, the TARGET LIST page will remain empty and records for T01 through T04 will have to be manually assigned to the desired Targetpoints. The next steps will show you how.

TARGET LIST				
PRESS RS+RA+[8] FOR LOADING INTO AIRCRAFT				
INDX	MGRS	COORD	ELEV.	RECORD
T01	37T GG	4037385444	30	251658242
T02	37T GG	3985482955	41	251658243
T03	37T GG	3976179873	18	251658244
T04	37T GG	3990977954	18	251658245

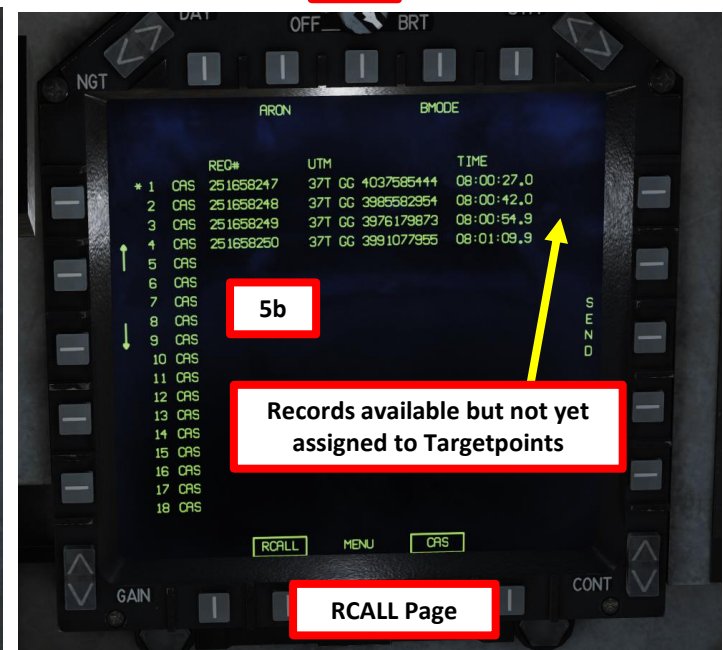
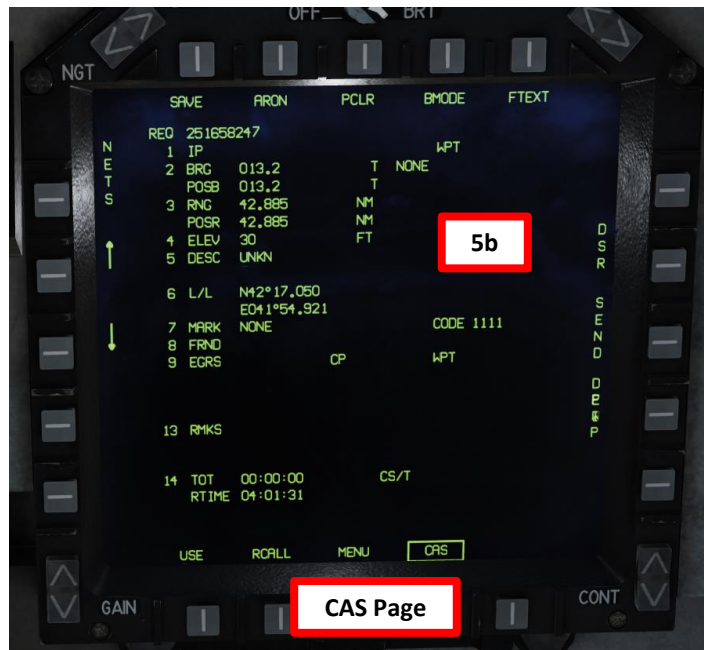
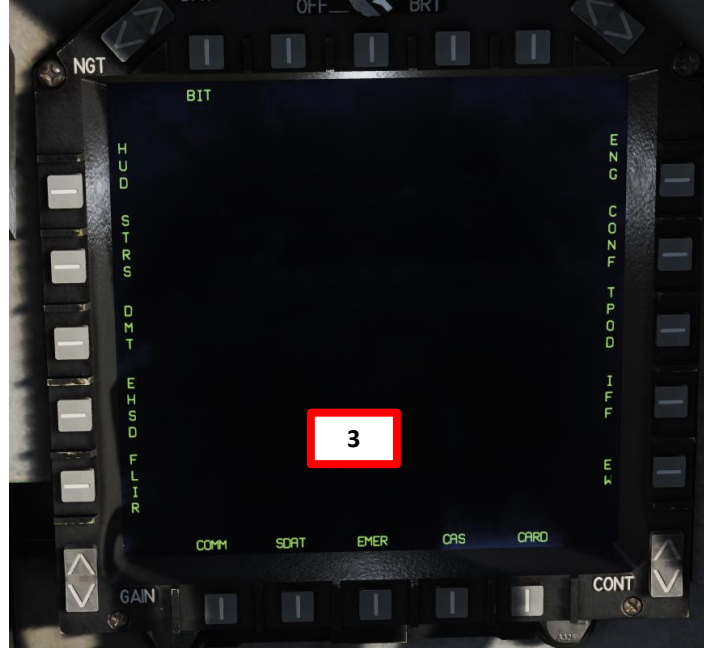

Records available but not yet assigned to Targetpoints

## 2.9.1 - GBU-38 JDAM PRE-PLANNED (ATHS)

### ASSIGN RECORDS TO TARGETPOINTS

Note: the following steps can be skipped if data was updated on the ground.

- In CAS page, select the first record that you want to assign to Targetpoint 1, which is REQ 251658247.
- Press on the OSB (Option Select Button) next to USE. The UFC (Up-Front Control) will become available to assign your desired Targetpoint.
- On the UFC, press “1”, then “ENT” to assign REQ 251658247 to Targetpoint 1.
- REQ 251658247 will become ACTIVE and assigned to Targetpoint 1.
- Select the next record (REQ 251658248).
- Press on the OSB (Option Select Button) next to USE. On the UFC, press “2” to assign REQ 251658248 to Targetpoint 2.
- Repeat previous steps for REQ 251658249/Targetpoint 3 and REQ 2516582450/Targetpoint 4.
- Press on the OSB next to RCALL (Recall) and confirm all records are assigned to the correct Targetpoint.

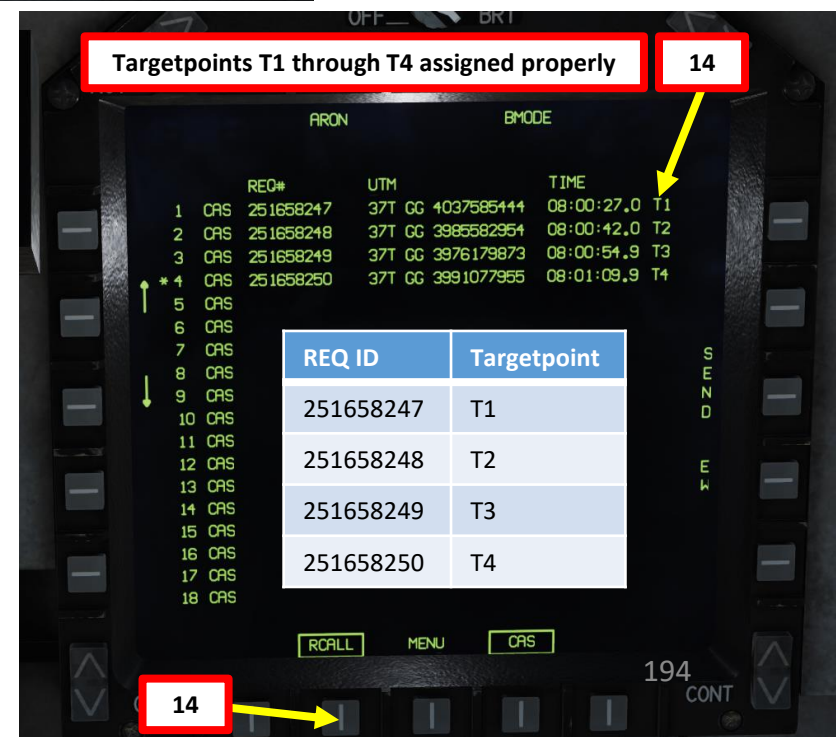
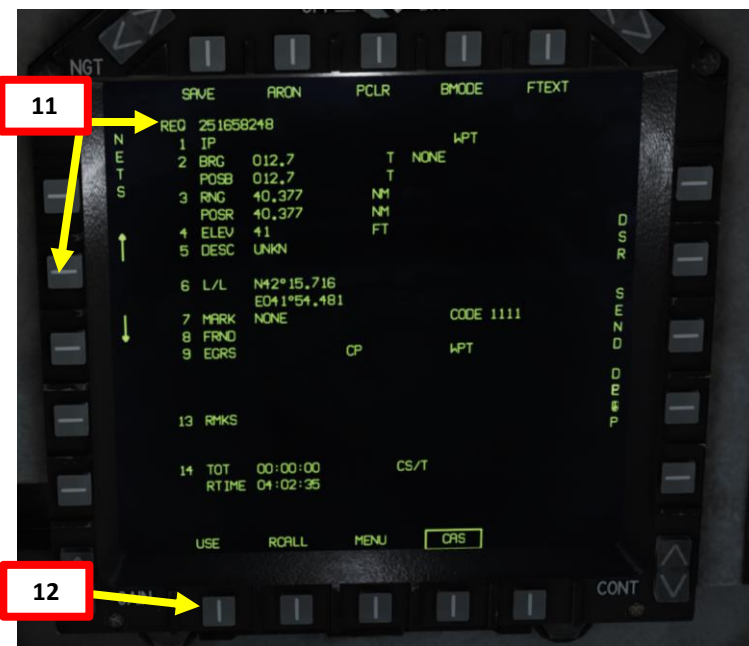
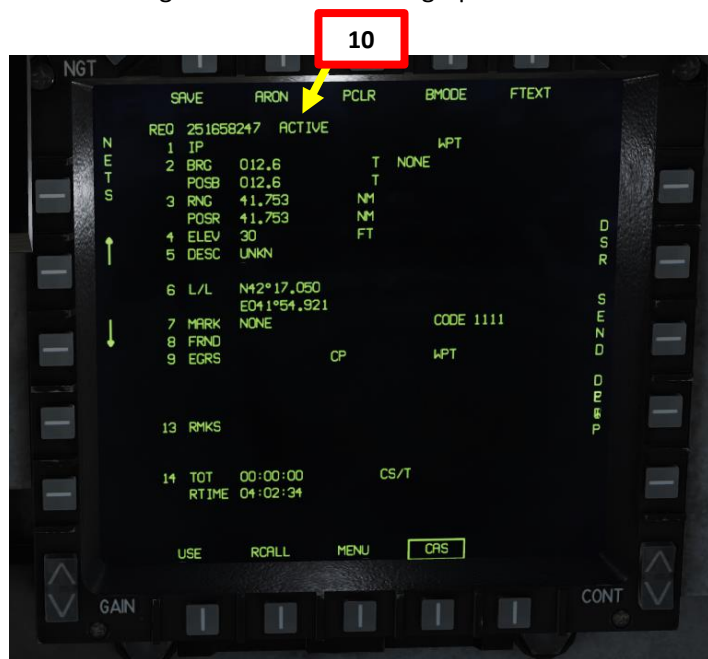
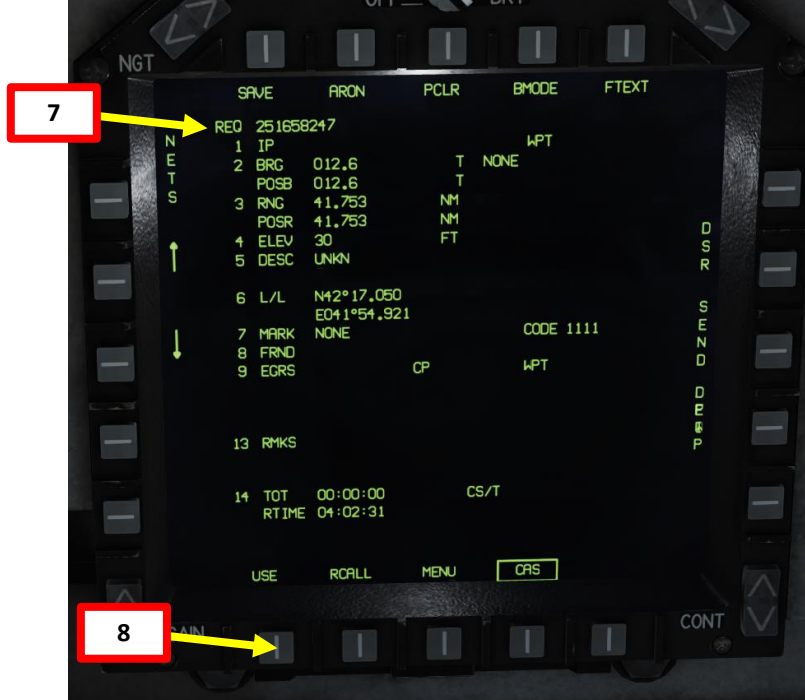

## 2.9.1 - GBU-38 JDAM PRE-PLANNED (ATHS)

### SET WEAPON RELEASE PARAMETERS

15. Set Master Arm Switch - ON (UP)
16. Set HUD Master Mode to A/G (Air-to-Ground)
17. Go in MPCD main MENU and select STRS (Stores) Page
18. Select desired J82 (GBU-38) JDAMs by either selecting them with the upper OSB (Option Select Button) or by pressing the pylon SEL buttons on the ACP (Armament Control Panel).
19. When aircraft generator is powered (engine running), the JDAM will automatically begin an alignment process that may take a few minutes. Alignment is complete when "ALN QUAL 00 GOOD" indication is visible.



## 2.9.1 - GBU-38 JDAM PRE-PLANNED (ATHS)

### SET WEAPON RELEASE PARAMETERS

20. Once weapon is selected, press the « WPN » button on the UFC to display available JDAM parameter ODU's (Option Display Units).
21. Press on TGTS ODU to select which targetpoints we will use for this attack. In our case, we will use Targetpoints 1, 2, 3 and 4. « : » will indicate when a targetpoint is selected.
22. Press on TGTS ODU again (then press EXIT) to return to return to JDAM parameters.
23. **OPTIONAL:** If desired, press on TERM ODU to select what Terminal Attack Parameters you want to set like attack heading and impact angle. These parameters are not simulated yet.
24. **OPTIONAL:** press on TERM ODU again to return to JDAM parameters.
25. **OPTIONAL:** If you want to enable the TERM (Terminal) Parameters on the JDAM, you must press the "Cage/Uncage" HOTAS Button.
26. Press on FUZE ODU to select the JDAM fuzing. In our case, we will choose INST (Instantaneous). « : » will indicate when selected.
27. Press on FUZE ODU again to return to JDAM parameters.
28. Now that our JDAM parameters are entered, we can now perform the JDAM strike.

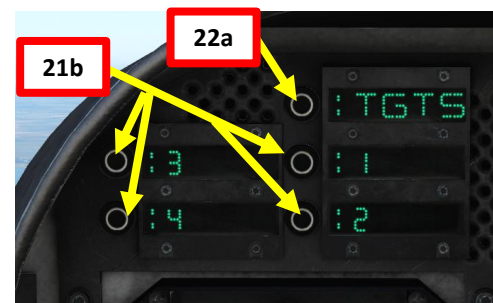
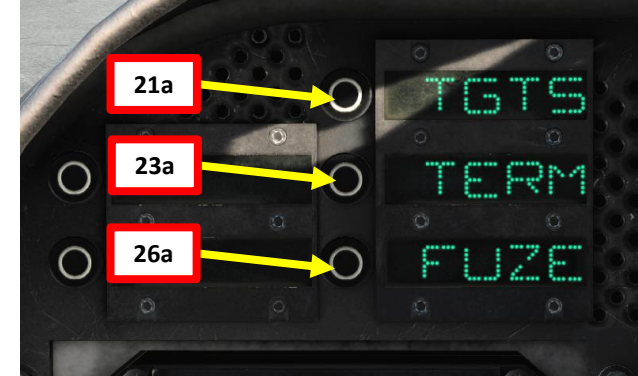

25 Weapon Cage/Uncage Switch

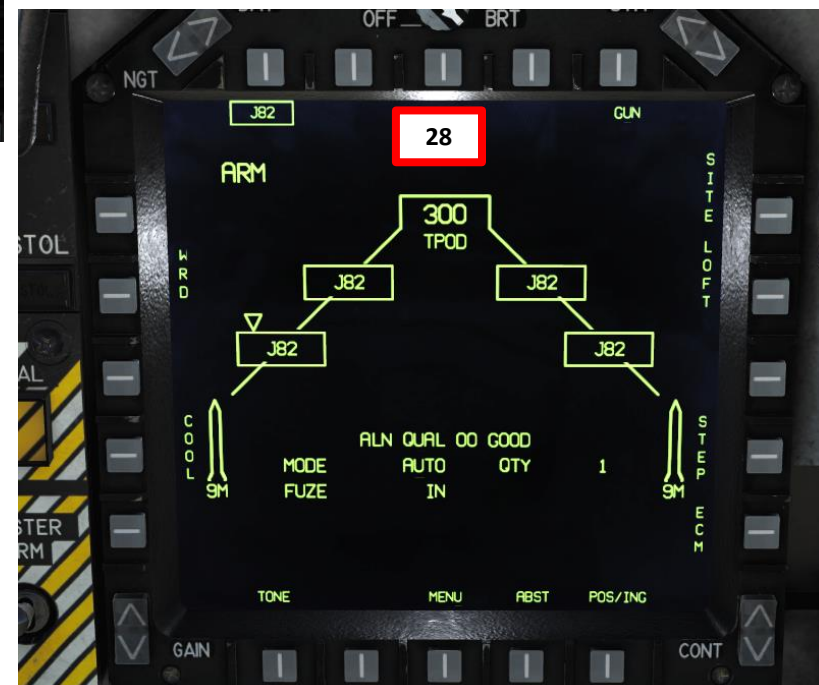

## 2.9.1 - GBU-38 JDAM PRE-PLANNED (ATHS)

### ATTACK

29. Go in MPCD main MENU and select EHSD (Electronic Horizontal Situation Indicator) Page
30. Press DESG (Designate) OSB. DESG should be boxed when selected.
31. Upon selection of the JDAM and DESG, only the center dot, Terminal Parameters Indicator and the bomb count and stores code are visible.
32. The JDAM range circle, LAR (Launch Acceptable Range) minimum value and the target list become visible.
33. Fly the aircraft level and line up the center dot with the JDAM Range Circle on the HUD.
34. When selecting multiple JDAM targets, the target diamond will show the position of the target centroid. The target centroid is the geometrical center of all the selected targets position.

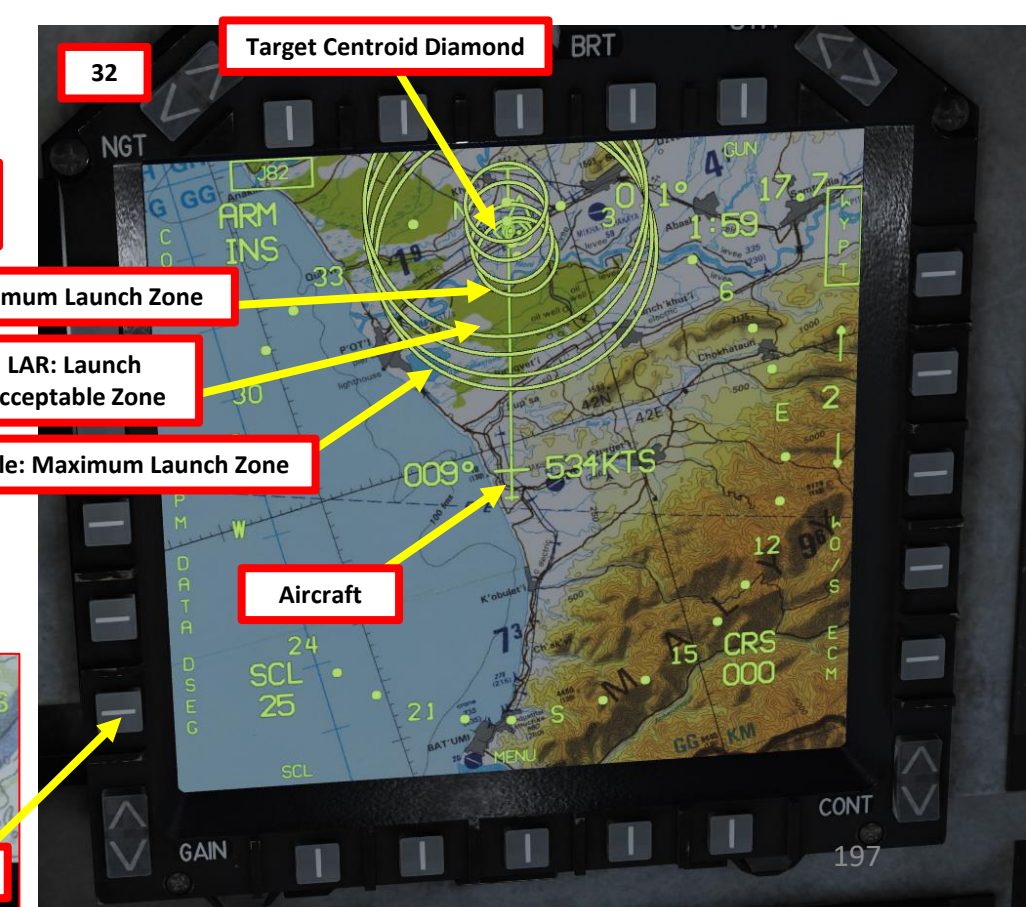
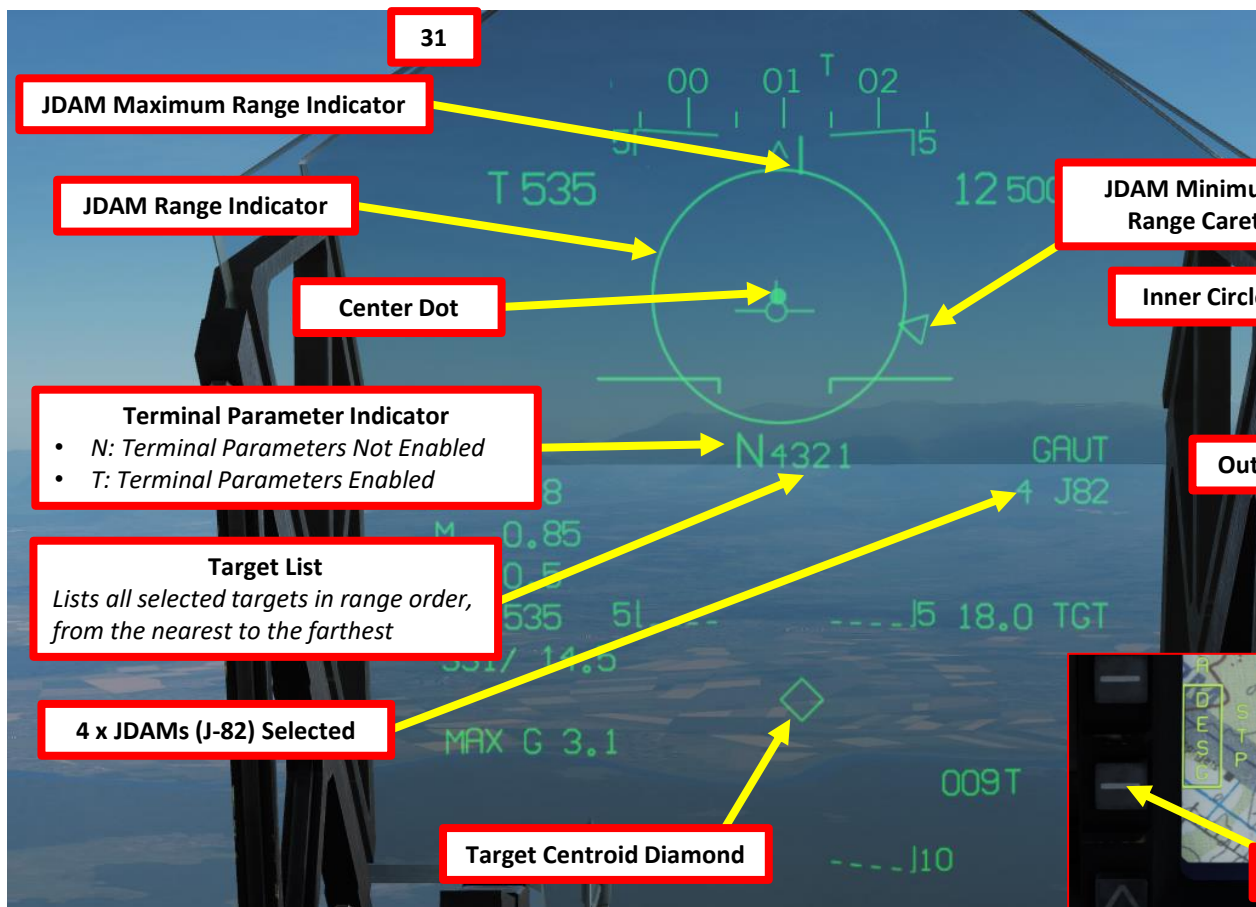

## 2.9.1 - GBU-38 JDAM PRE-PLANNED (ATHS)

### ATTACK

35. The aircraft will be in bomb release range as soon as it enters the LAR zone. The HUD will indicate his condition when:
  - a) The target number font becomes larger.
  - b) The Range to Target appears inside the Range Circle and its edge starts moving towards the Minimum LAR Marker.
  - c) The LAR Percentage number (% to the center of the LAR the aircraft is at) appears in the bottom of the HUD and starts counting towards 100.
36. The bombs can be released as soon as the aircraft is inside the LAR zone. For better results it is advisable to wait until the aircraft is in the center of the LAR zone before release. Check the LAR Percentage indicator on the HUD and release as soon as the indicated value is near 100.
37. Press the Bomb Pickle button (RALT+SPACE) to launch the first JDAM. Repeat for remaining JDAMs.

- Note 1: If multiple targets are selected, their respective JDAM bombs will be released at 1 second interval as long as the pickle is being pressed.
- Note 2: There is no automatic bomb release. The pilot must judge when it is time to release the bomb.

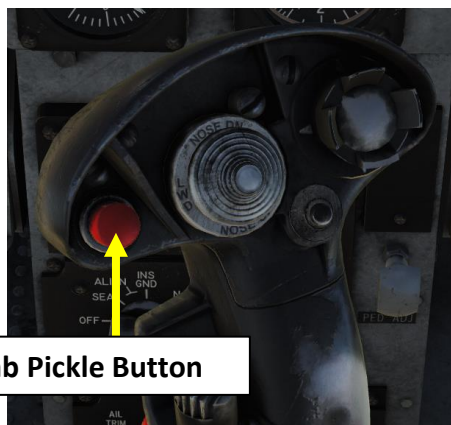

37 Bomb Pickle Button

35b JDAM Range Indicator

35

35a

35c LAR Percentage Number

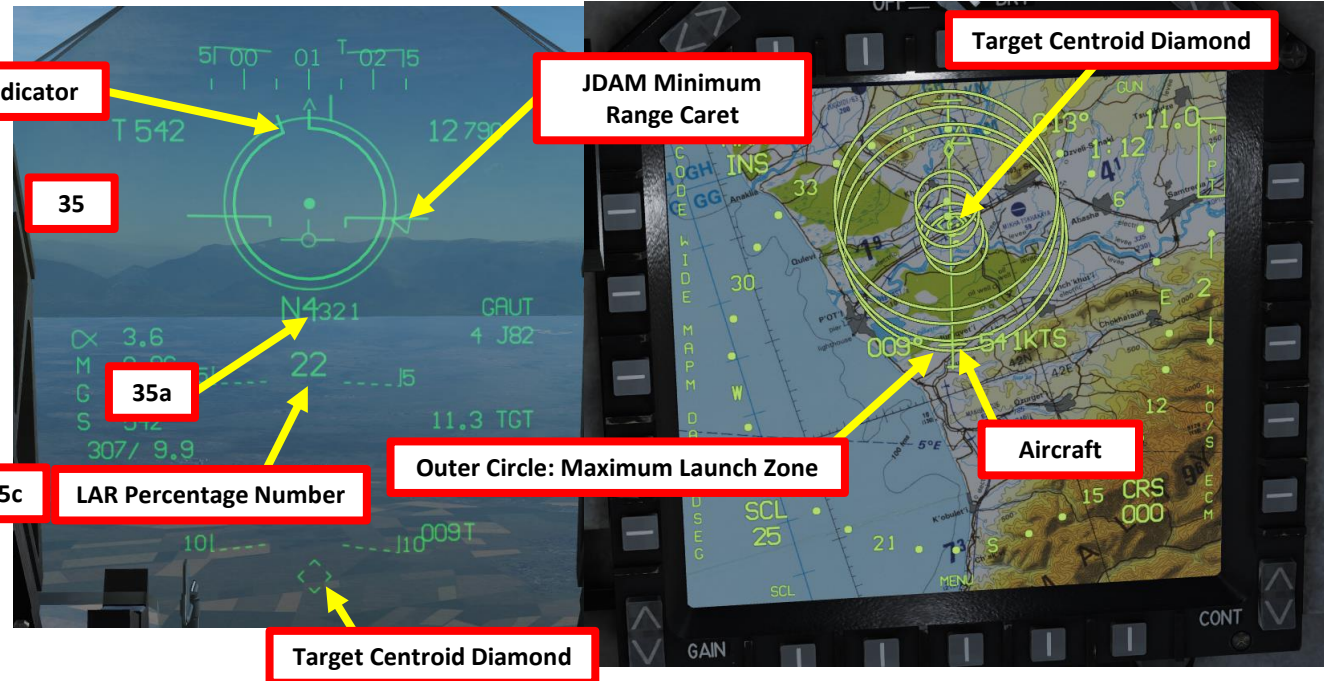

Outer Circle: Maximum Launch Zone

Aircraft

Target Centroid Diamond

JDAM Range Indicator

JDAM Minimum Range Caret

36

Aircraft

Outer Circle: Maximum Launch Zone

Target Centroid Diamond

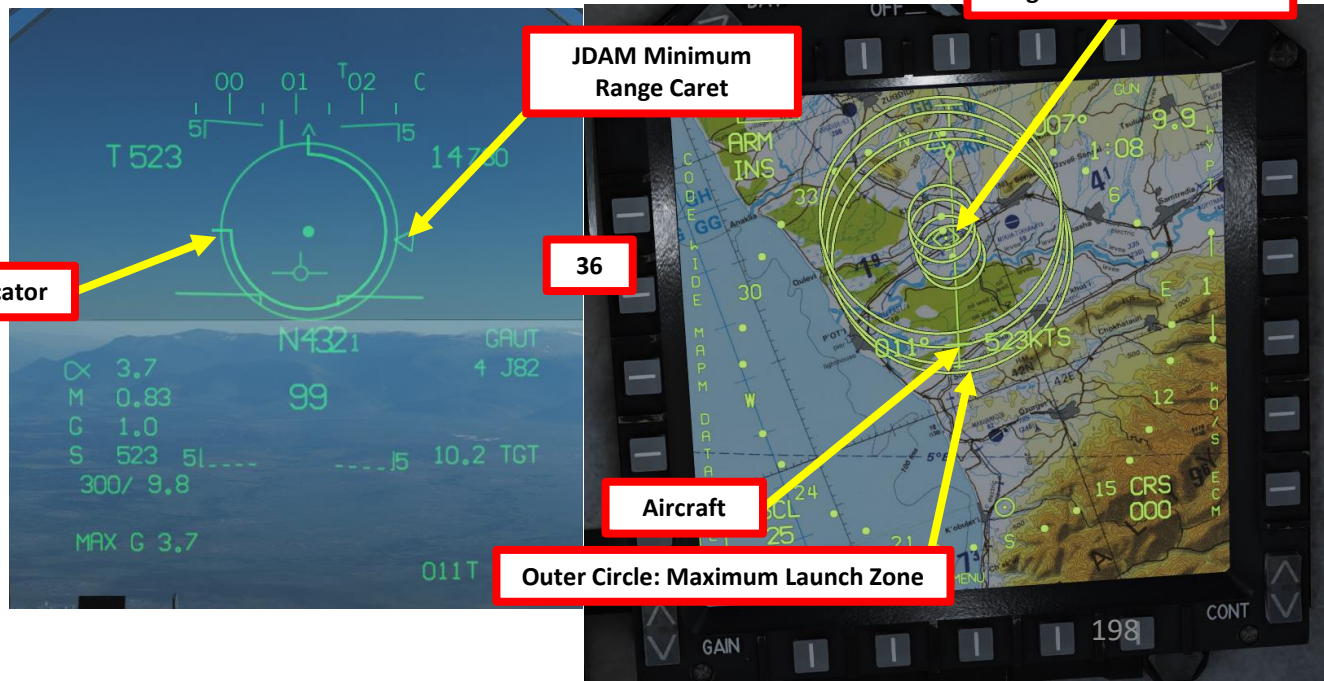

2.9.1 - GBU-38 JDAM  
PRE-PLANNED (ATHS)

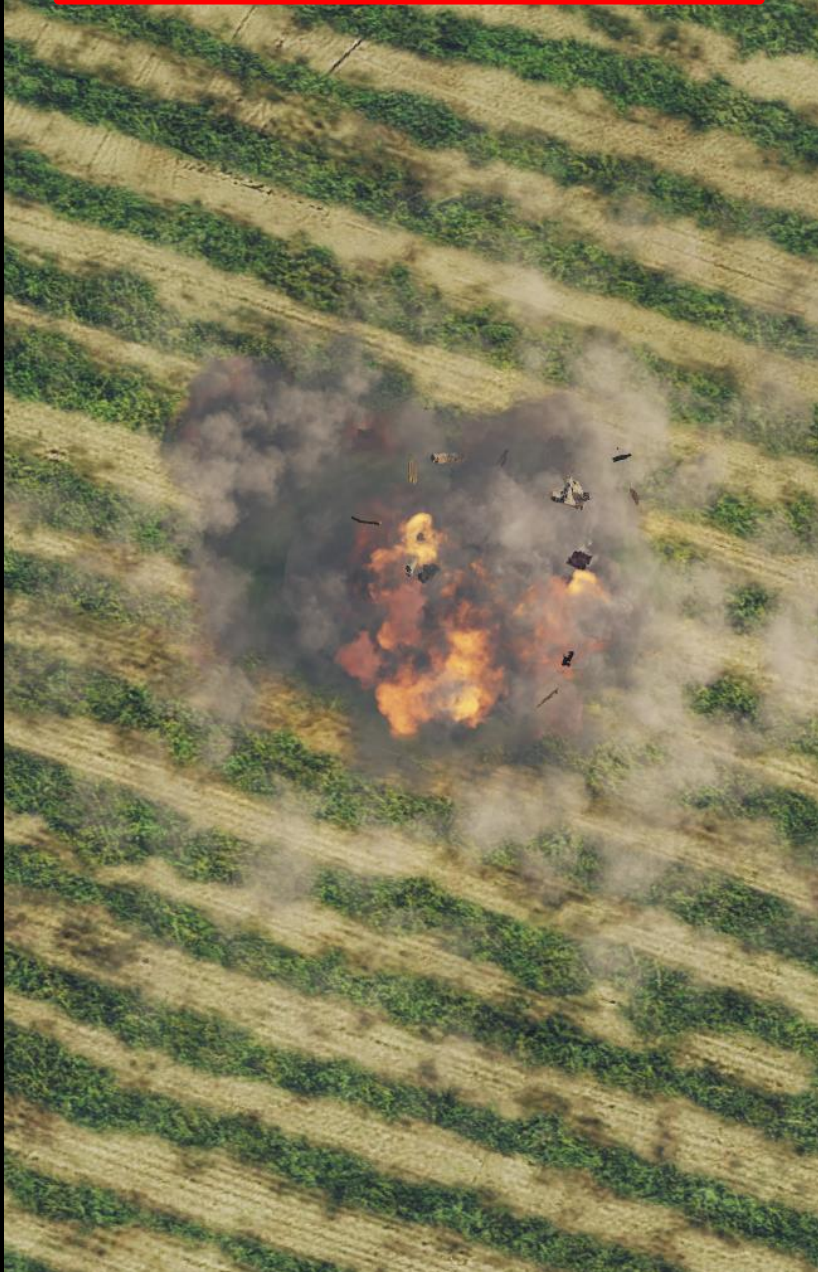

## 2.9.2 - GBU-38 JDAM TOO (TARGETING POD)

### SET WEAPON RELEASE PARAMETERS

1. Set Master Arm Switch - ON (UP)
2. Set HUD Master Mode to A/G (Air-to-Ground)
3. Go in MPCD main MENU and select STRS (Stores) Page
4. Select desired J82 (GBU-38) JDAMs by either selecting them with the upper OSB (Option Select Button) or by pressing the pylon SEL buttons on the ACP (Armament Control Panel).
5. When aircraft generator is powered (engine running), the JDAM will automatically begin an alignment process that may take a few minutes. Alignment is complete when "ALN QUAL 00 GOOD" indication is visible.



## 2.9.2 - GBU-38 JDAM TOO (TARGETING POD)

### SET WEAPON RELEASE PARAMETERS

6. Once weapon is selected, press the « WPN » button on the UFC to display available JDAM parameter ODU's (Option Display Units).
7. **OPTIONAL:** If desired, press on TERM ODU to select what Terminal Attack Parameters you want to set like attack heading and impact angle. These parameters are not simulated yet.
8. **OPTIONAL:** press on TERM ODU again to return to JDAM parameters.
9. **OPTIONAL:** If you want to enable the TERM (Terminal) Parameters on the JDAM, you must press the "Cage/Uncage" HOTAS Button.
10. Press on FUZE ODU to select the JDAM fuzing. In our case, we will choose INST (Instantaneous). « : » will indicate when selected.
11. Press on FUZE ODU again to return to JDAM parameters.
12. Now that our JDAM parameters are entered, we can now perform the JDAM strike.

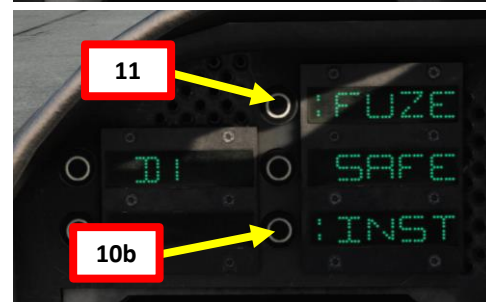
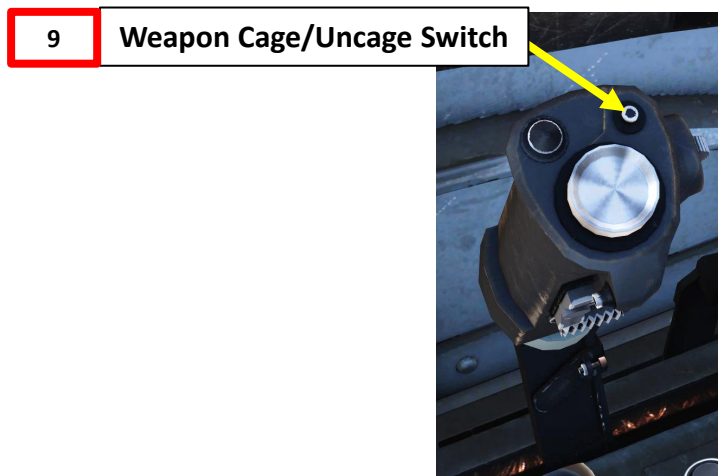
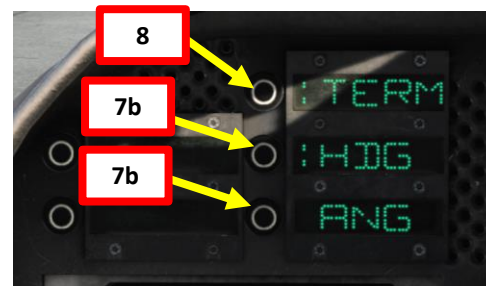
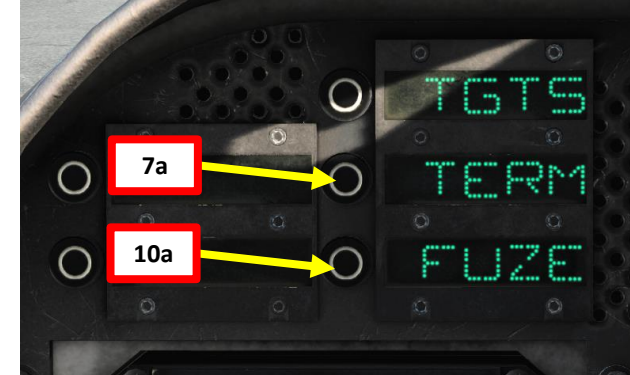

## 2.9.2 - GBU-38 JDAM TOO (TARGETING POD)

### DESIGNATE TARGET WITH TARGETING POD

13. **OPTIONAL:** Set laser code as required: Go in EHSD page, press the OSB (Option Select Button) next to CODE (should be boxed), then set required laser code on the keypad (standard code is **1688**), then press ENT. Unbox CODE by pressing OSB again. Default laser code **1111** is an initialization code **and will not work**.
14. Power up the Targeting Pod:
  - a) Click on the OSB next to the “TPOD” page in the main MPCD MENU
  - b) Clicking the OSB next to STBY
  - c) The Targeting Pod will start its initialization for 3 minutes.
  - d) After initialization, the pod starts FLIR cooling, which takes approximately 6 to 8 minutes. Pod will display F-NOTRDY (FLIR Not Ready) indication when FLIR cooling is incomplete.
15. In order to use the TDC (Target Designation Caret), press the Sensor Select Switch DOWN twice to use TPOD Mode.
16. Slew your TDC using the TDC LEFT/RIGHT/FWD/AFT controls.
17. Press the « TDC DOWN Action Position » button to designate a target.
18. Select desired Laser Options (LASR)
19. Arm Laser (ARMED), then fire Laser to obtain more accurate ranging information. Stop firing laser when accurate range is obtained.

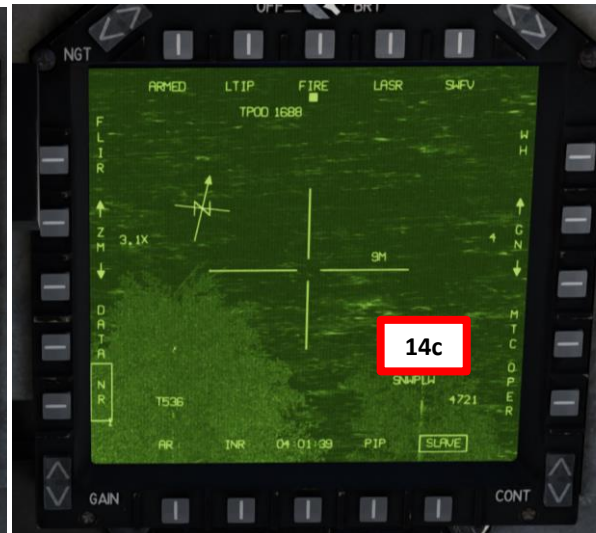
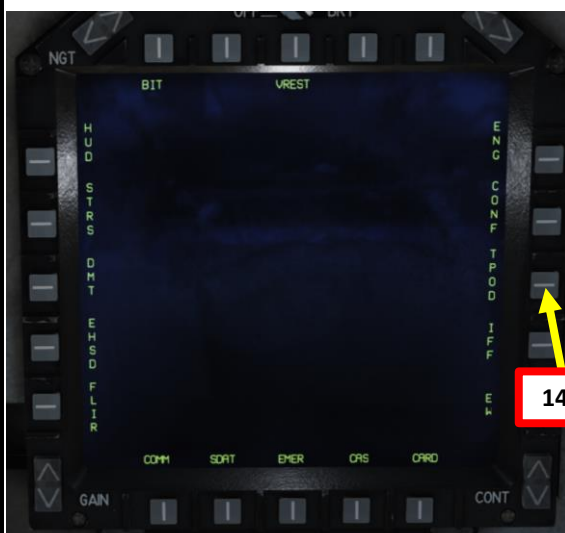
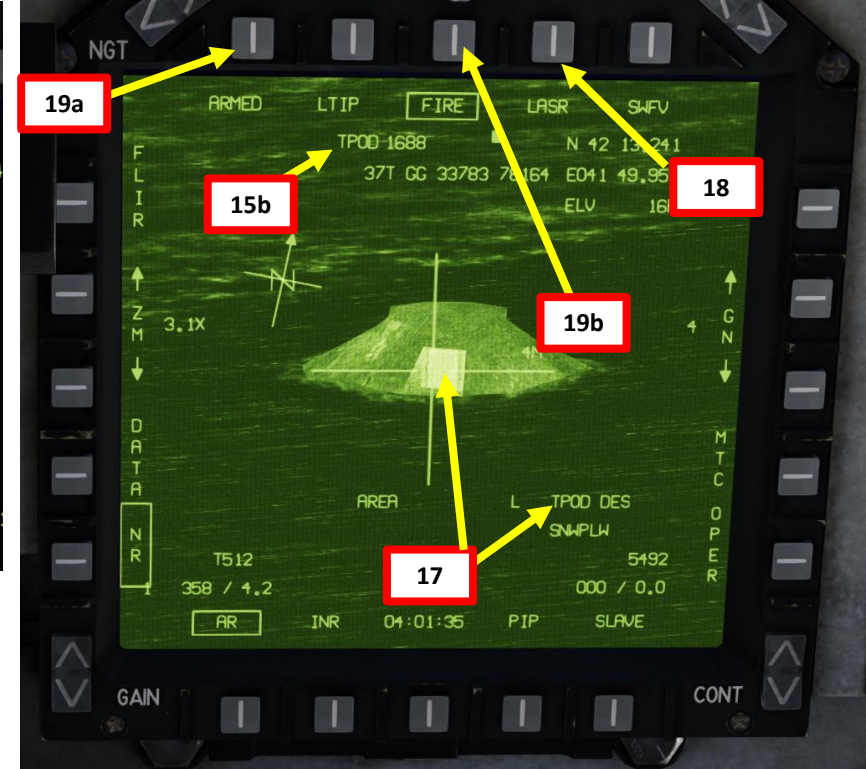
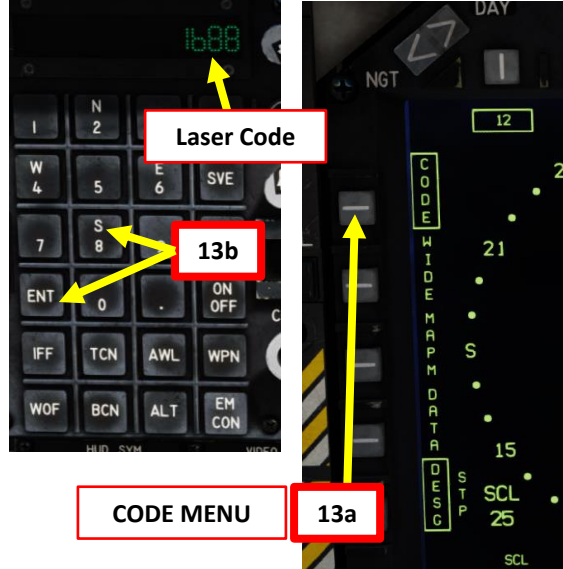

TDC (Target Designation Caret) Control Switch LEFT/RIGHT/FORWARD/AFT/DOWN (ACTION)



## 2.9.2 - GBU-38 JDAM TOO (TARGETING POD)

### ATTACK

- Go in MPCD main MENU and select EHSD (Electronic Horizontal Situation Indicator) Page. Press DESG (Designate) OSB. DESG should be boxed when selected.
- Upon selection of the JDAM, only the center dot and the bomb count and stores code are visible.
- Press the Waypoint Increment Button for more than 0.8 sec to set the tracked position of the targeting pod as your Targetpoint 0.
- The JDAM range circle, LAR (Launch Acceptable Range) minimum value, Terminal Parameters Indicator and the target list (which is only "0" since we use Target-of-Opportunity (TOO) mode) become visible.
- Fly the aircraft level and line up the center dot with the JDAM Range Circle on the HUD.

22

Waypoint Increment Button

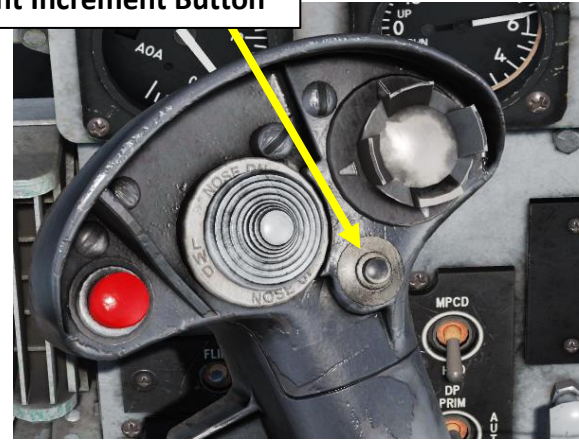

JDAM Maximum Range Indicator

JDAM Range Indicator

Center Dot

Terminal Parameter Indicator

- N: Terminal Parameters Not Enabled
- T: Terminal Parameters Enabled

Target List

"0" lists targetpoint 0 (TOO mode)

4 x JDAMs (J-82) Selected

23

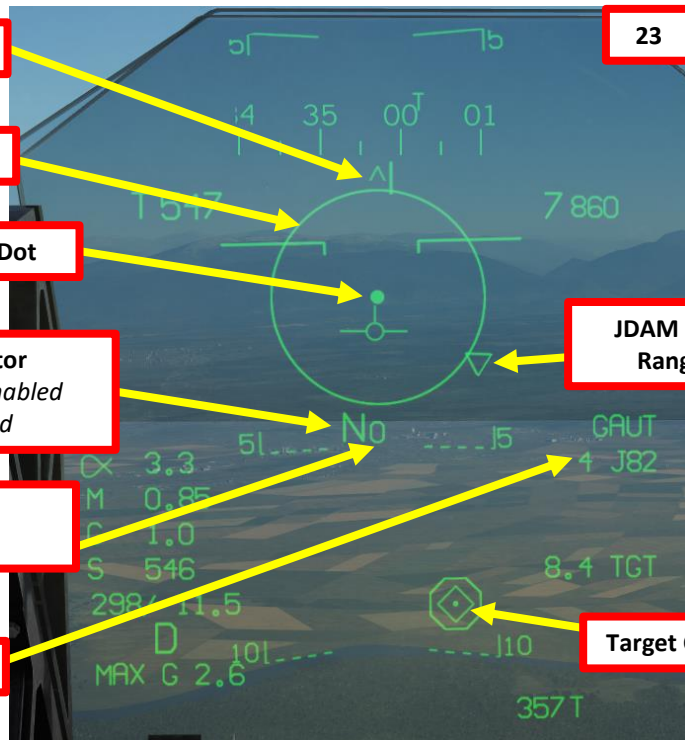

JDAM Minimum Range Caret

Inner Circle: Minimum Launch Zone

LAR: Launch Acceptable Zone

Outer Circle: Maximum Launch Zone

Aircraft

Target Centroid Diamond

23

Target Centroid Diamond

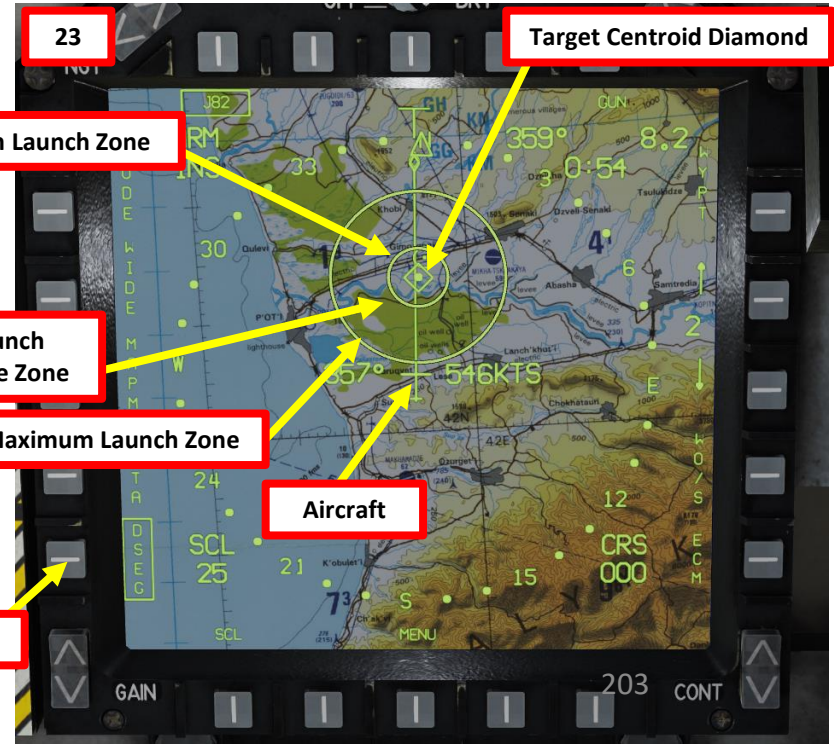

20

## 2.9.2 - GBU-38 JDAM TOO (TARGETING POD)

### ATTACK

25. The aircraft will be in bomb release range as soon as it enters the LAR zone. The HUD will indicate his condition when:
  - a) The target number font becomes larger.
  - b) The Range to Target appears inside the Range Circle and its edge starts moving towards the Minimum LAR Marker.
  - c) The LAR Percentage number (% to the center of the LAR the aircraft is at) appears in the bottom of the HUD and starts counting towards 100.
26. The bomb can be released as soon as the aircraft is inside the LAR zone. For better results it is advisable to wait until the aircraft is in the center of the LAR zone before release. Check the LAR Percentage indicator on the HUD and release as soon as the indicated value is near 100.
27. Press the Bomb Pickle button (RALT+SPACE) to launch the JDAM

**Note 1:** There is no automatic bomb release. The pilot must judge when it is time to release the bomb.

**Note 2:** By a Long Press (more than 1 second) of the “WP Increment” HOTAS Key. This will ONLY clear the JDAM Relative Target designation. The Aircraft Designated Target will still be active. Alternatively, you can also deselect target by Pressing the “AG Target Undesignate / NWS / FOV Toggle” HOTAS Key, which will clear both the Aircraft Designated Target and the JDAM Relative Target

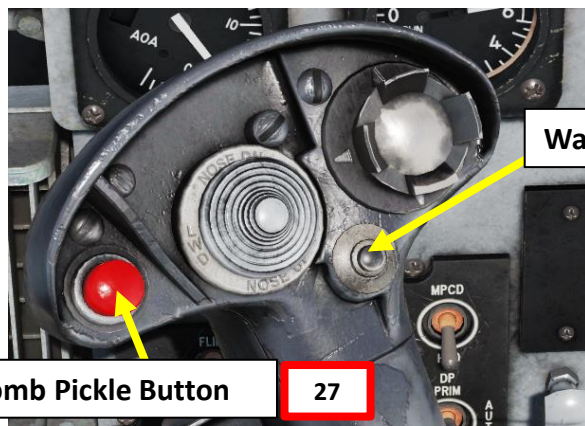

25b JDAM Range Indicator

25

JDAM Minimum Range Caret

25a

25c LAR Percentage Number

26

JDAM Range Indicator

JDAM Minimum Range Caret

LAR Percentage Number

Inner Circle: Minimum Launch Zone

Aircraft

Target Centroid Diamond

Outer Circle: Maximum Launch Zone

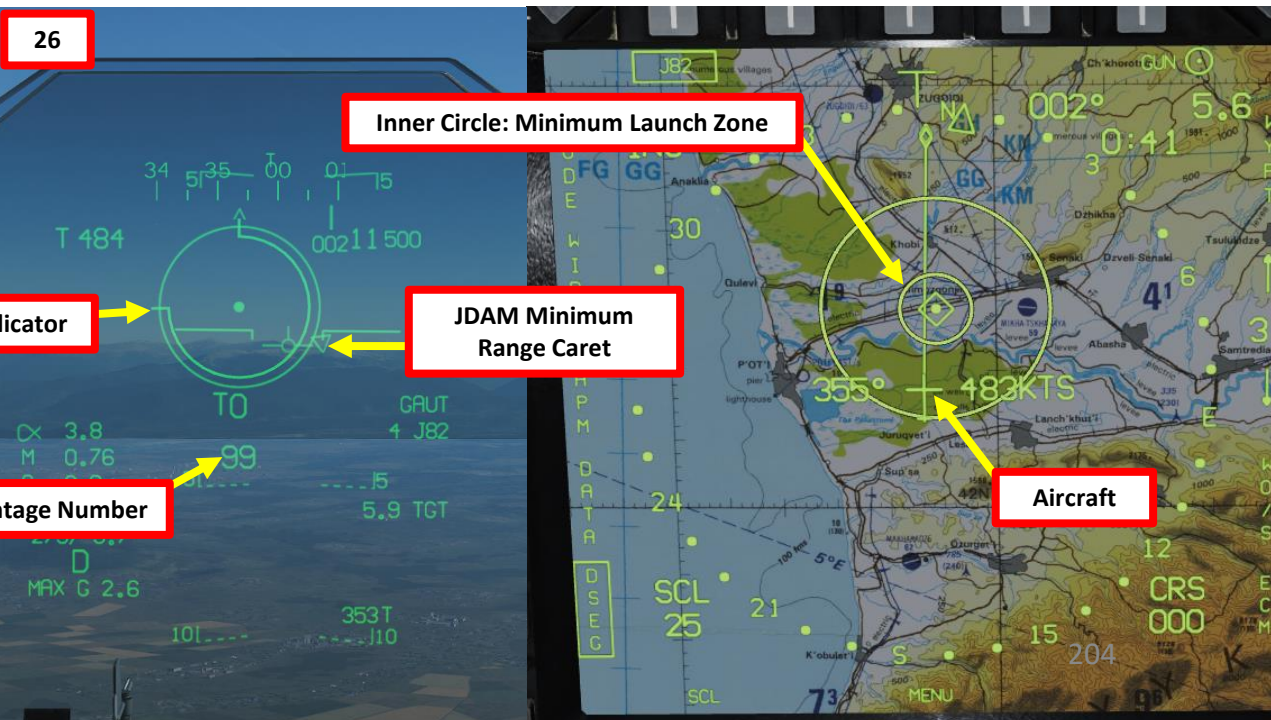
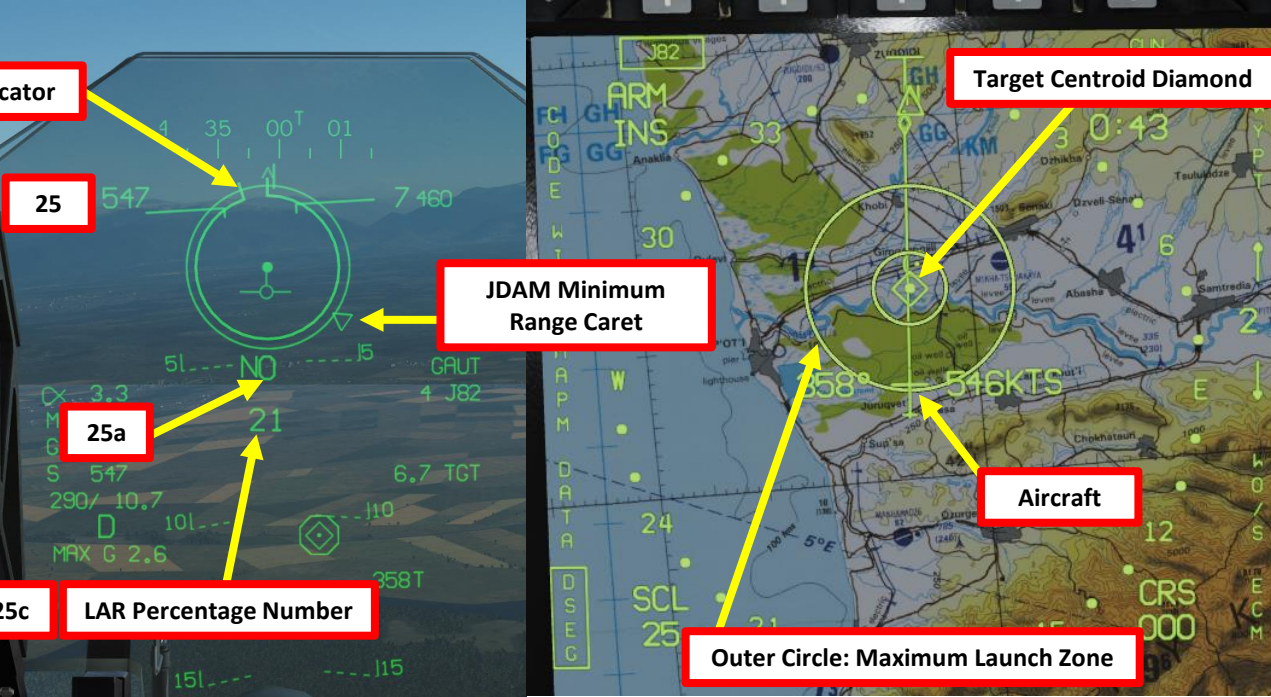

2.9.2 - GBU-38 JDAM  
TOO (TARGETING POD)

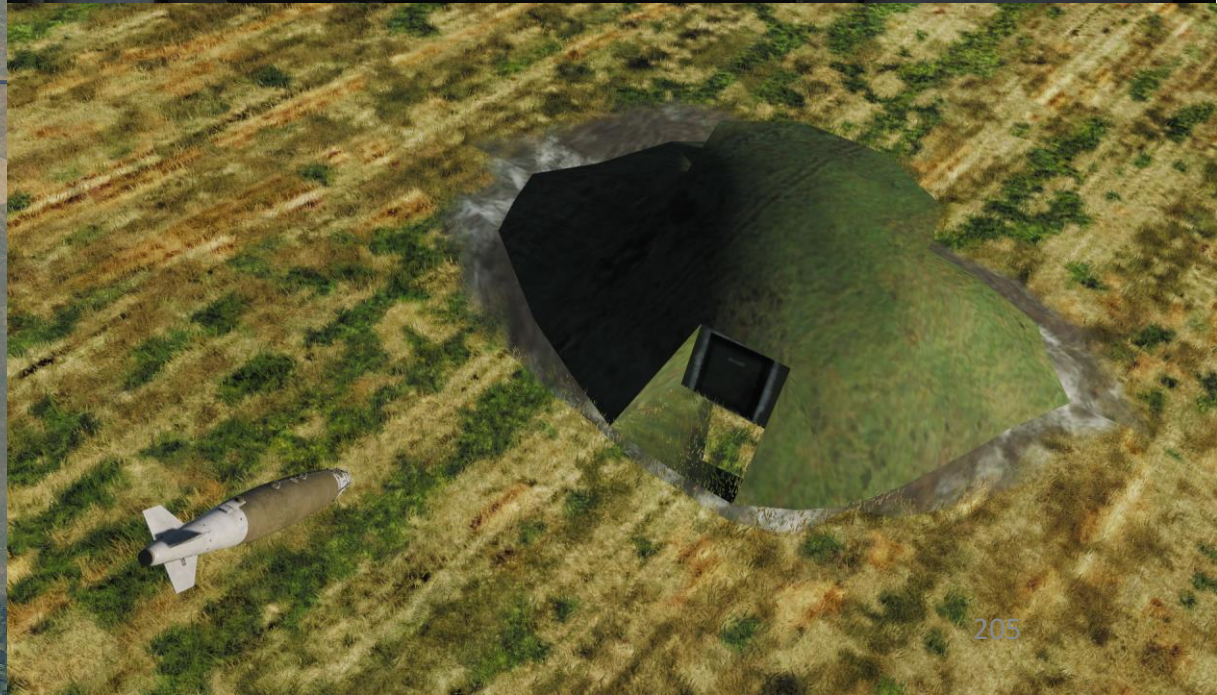
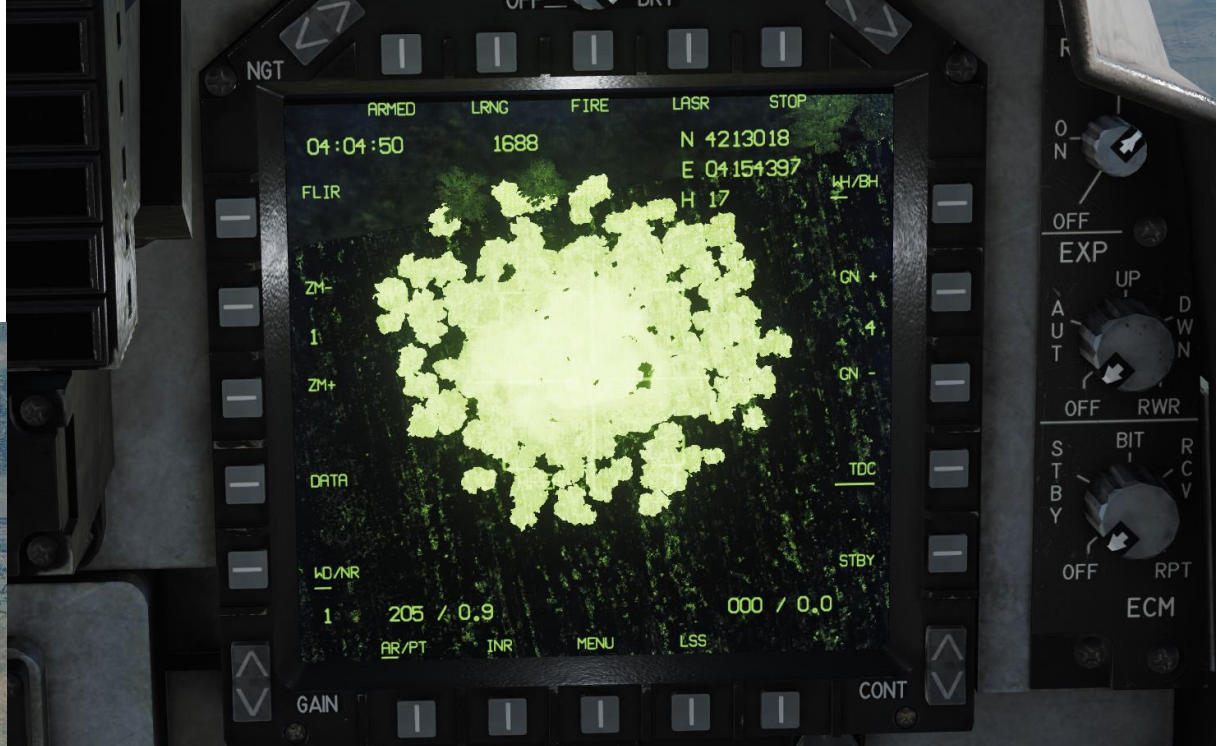

### 3.1 - GAU-12 GUN POD (AIR-TO-AIR)

1. Set Master Arm Switch – ON (UP)
2. Press the A/A Mode DOWN: Gun switch on your HOTAS (C key binding by default)
3. Set gun piper on target. It is a pure boresight mode.
4. Press the Trigger (Fire Gun - SPACE) button to fire gun.
5. Keep in mind that the gun pod is located to the left and will induce a yaw moment when firing. You will have to compensate it with your rudder.

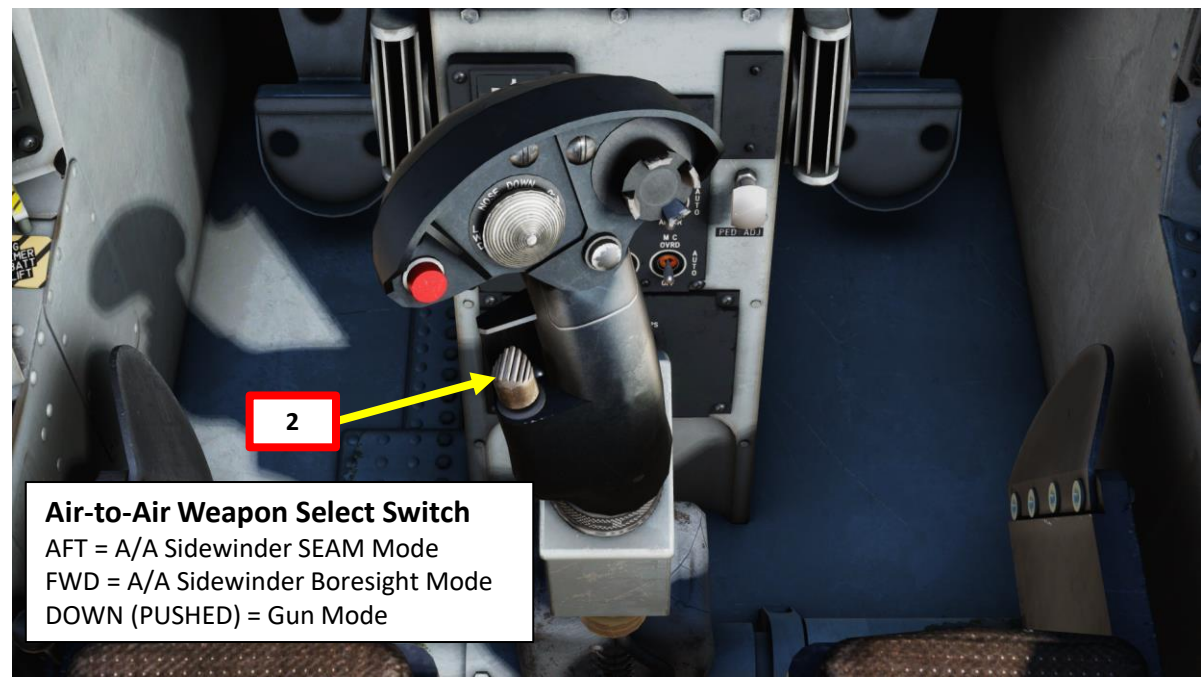

3.1 - GAU-12 GUN POD (AIR-TO-AIR)

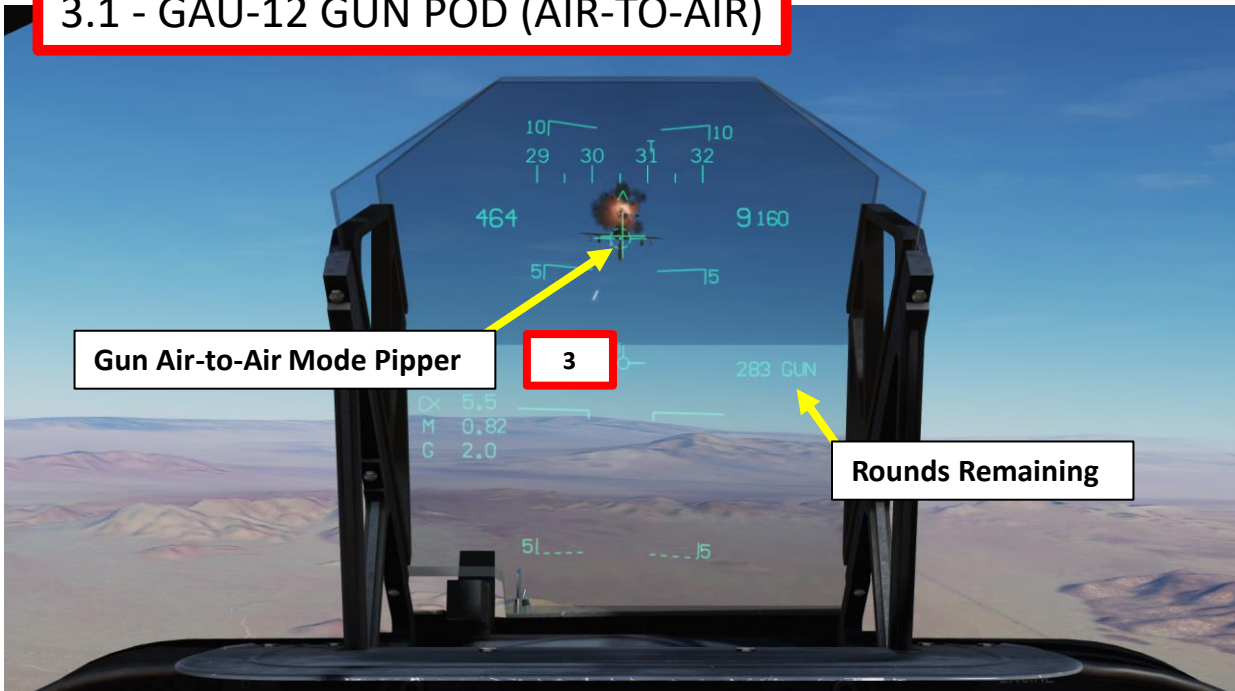

### 3.2 - AIM-9M SIDEWINDER AIR-TO-AIR MISSILE

1. Set Master Arm switch ON (UP)
2. Set either Air-to-Air Weapon Select switch to AFT (A/A Sidewinder SEAM Mode) or to FWD (A/A Sidewinder Boresight Mode) to power on IR missile seeker. Sidewinder will start a low-pitch growl when seeking.
  - SEAM mode (Sidewinder Expanded Acquisition Mode) will rotate its seeker head around to have a greater field of view.
  - Boresight mode will make the seeker head look straight in front of you with a reduced field of view.
3. When within firing range, the seeker growling will become high-pitched and seeker circle will become full.
4. Press the Trigger (Fire Gun - SPACE) button to fire missile.



Seeker has locked on target

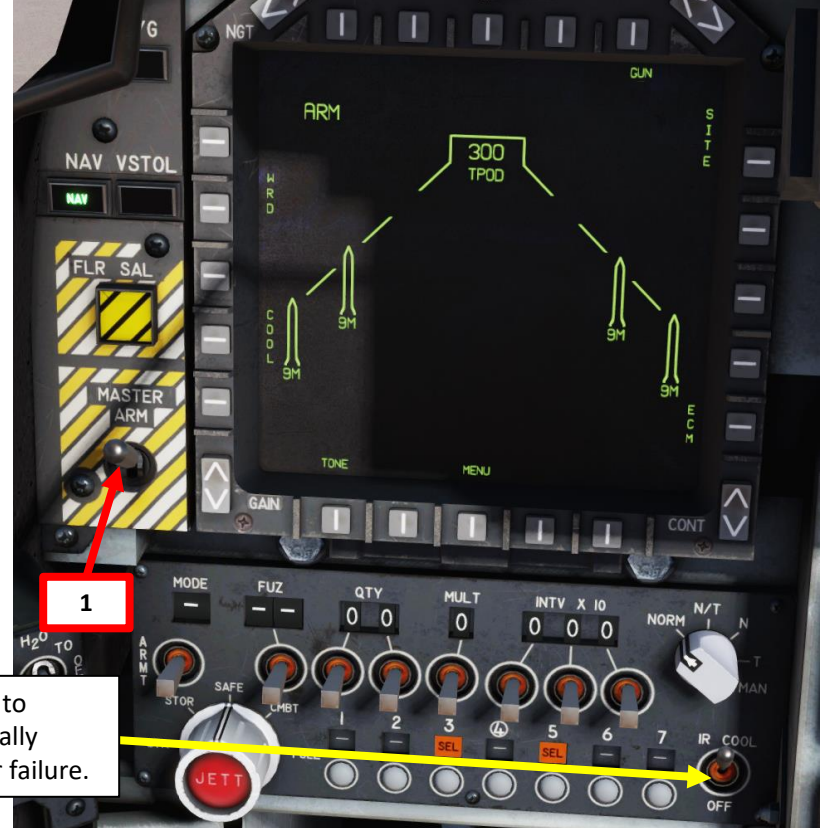

IR COOL is for manually cooling the Sidewinder seekers prior to selecting and arming them (which would normally automatically initiate cooling at this point) or in the case of some computer failure.



**Air-to-Air Weapon Select Switch**  
 AFT = A/A Sidewinder SEAM Mode  
 FWD = A/A Sidewinder Boresight Mode  
 DOWN (PUSHED) = Gun Mode

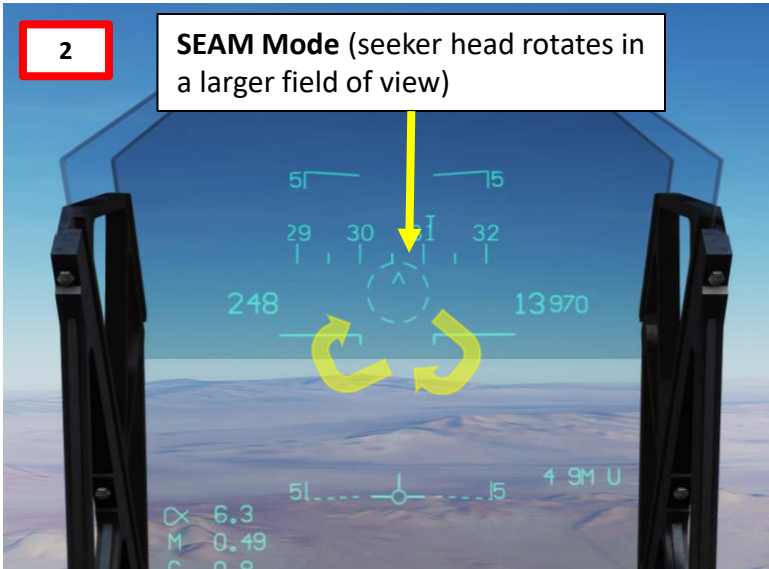

**SEAM Mode** (seeker head rotates in a larger field of view)

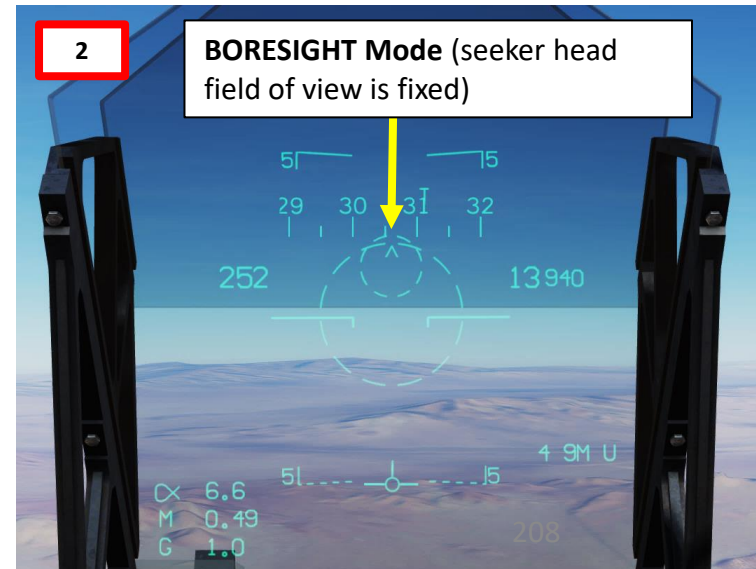

**BORESIGHT Mode** (seeker head field of view is fixed)

3.2 - AIM-9M SIDEWINDER  
AIR-TO-AIR MISSILE



## INTRODUCTION

Countermeasures are very simple to use. You have three countermeasure types at your disposal: flares, chaff and an ECM (Electronic Countermeasure) jammer. We will explore together what is used against what, and how.

Missiles can generally track you using 2 things: radar signature (radar waves are sent on you and you reflect them, which is called a “radar signature”) and heat signature (like the exhaust of your engines). Countermeasures will only be effective against the kind of weapon it was meant to counter; a heat-seeking missile will not care if you deploy electronic countermeasures against it since it tracks heat, not radar signatures. This is why it is important to know what is attacking you in order to counter it properly. This is what the **RWR** (Radar Warning Receiver) is for: to help you know what is firing at you so you can take the adequate action to counter it. Keep in mind that the Harrier **does not have a MLWS** (Missile Launch Warning System), so you cannot know when a missile has been fired at you and is actively tracking you.

**Flares** are used against missiles that track heat (infrared or IR) signatures. Instead of going for the heat signature generated by your engines, a missile will go for a hotter heat source like flares.

**Chaff** is a form of “passive” jamming. Passive (reflected) jamming is when a deceptive object or device reflects radar waves. Chaff is simply a bundle of small pieces of metal foil with reflective coating, which creates clusters of radar signatures that prevent a radar to get a solid lock on the aircraft itself.

The **AN/ALQ-164 DECM jammer pod** is a form of “continuous” jamming, also called “active” or “transmitted” jamming. This device transmits its own synchronized radar waves back at your enemy’s radar receiver to simulate erroneous radar wave returns. Simply put, active jamming will try to drown a radar in white noise.

In order to use these three forms of countermeasures, you can use “countermeasure programs”, routines that will deploy a number of flares/chaff for a number of cycles at a given interval.

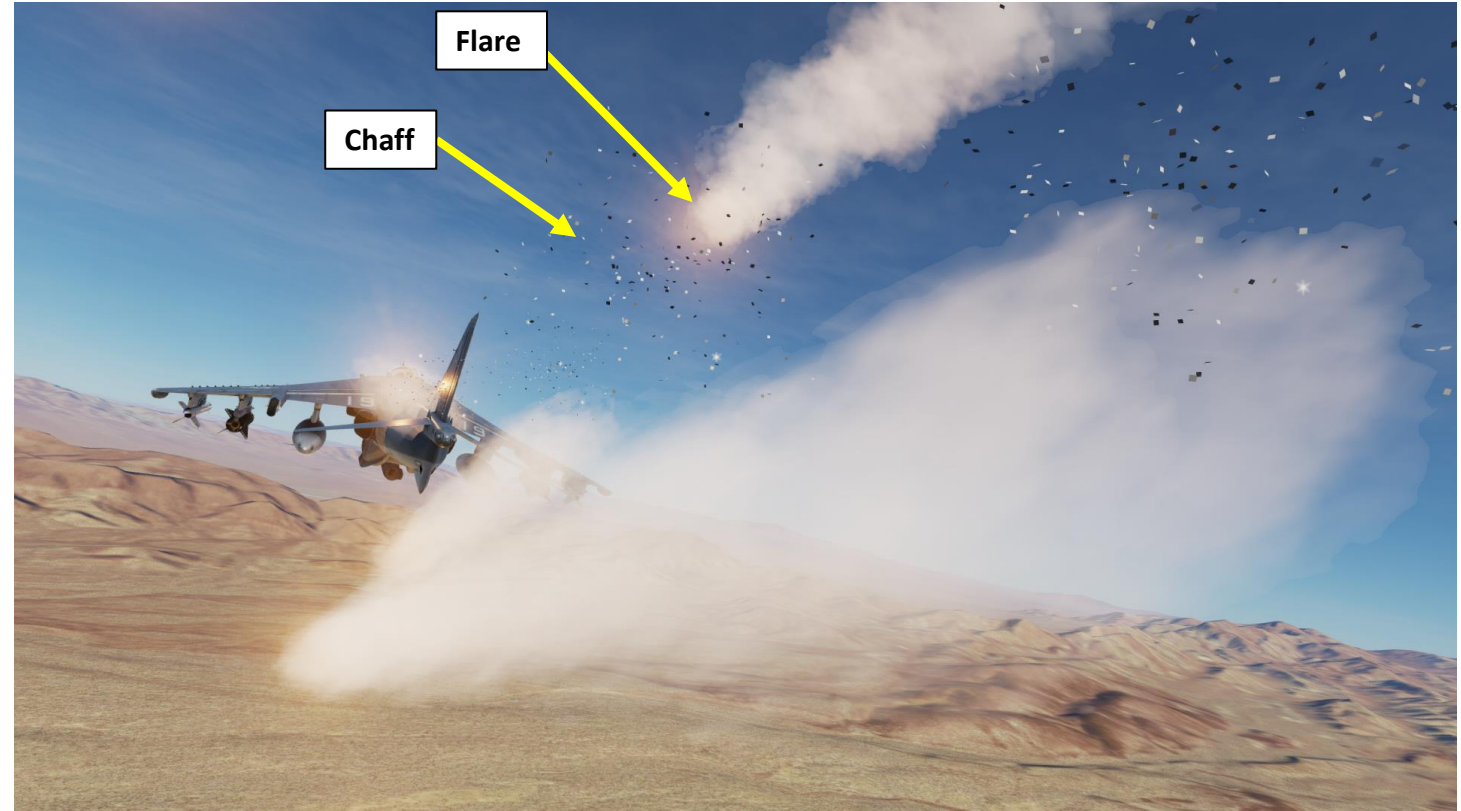

# COUNTERMEASURES CONTROL SETUP

ECM DISPENSE RIGHT: ALL  
(Grey button on RHS)

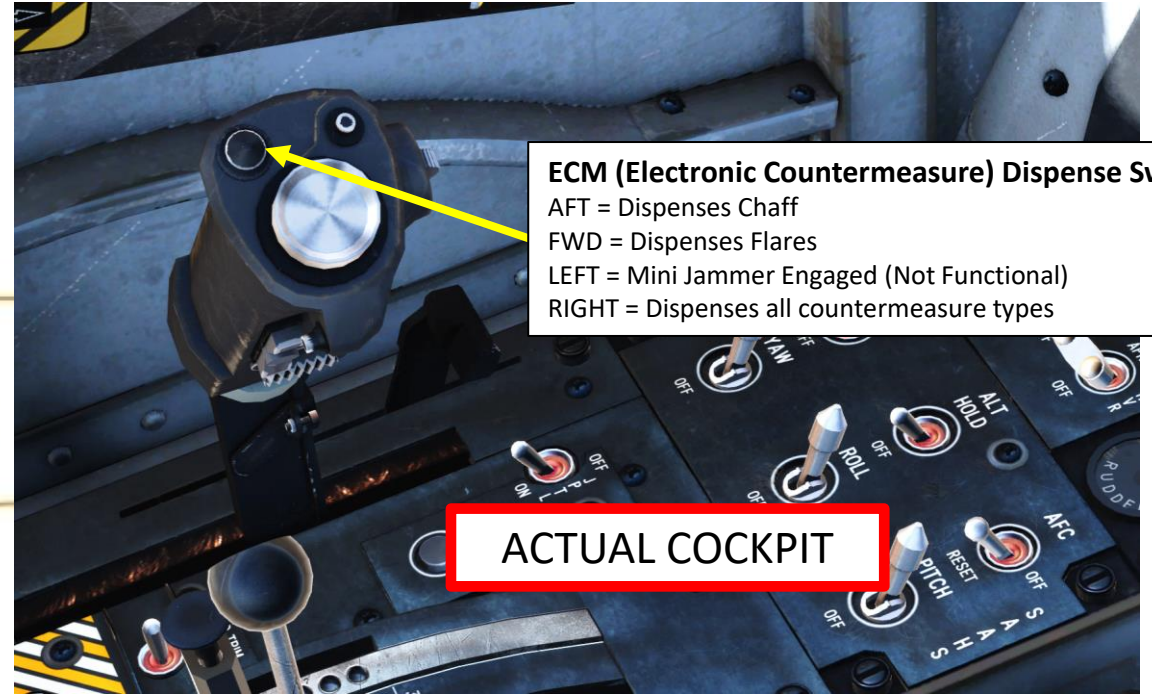

**ECM (Electronic Countermeasure) Dispense Switch**  
AFT = Dispenses Chaff  
FWD = Dispenses Flares  
LEFT = Mini Jammer Engaged (Not Functional)  
RIGHT = Dispenses all countermeasure types

ACTUAL COCKPIT

THRUSTMASTER  
WARTHOG

← ECM DISPENSE AFT: CHAFF  
→ ECM DISPENSE FWD: FLARES



## AN/ALR-67(v) RWR (RADAR WARNING RECEIVER)

Your RWR will tell you what is around you with a top-down view, both friendly and enemy contacts. The closer the symbol to the center of the circle, the stronger the radar signal strength.

The RWR display consists of 4 concentric circles at predetermined intervals. The circles do not represent range but signal strength and priority. Each detected signal displayed consists of two parts: an alphanumeric code that identifies signal type, and a symbol that indicates emitter platform and priority. The RWR is also displayed on your Heads-Up Display in a top-down view (up is forward, down is aft)

To power up the RWR, just set the RWR selector to ON. You can access the RWR by going in the main MPCD menu and clicking "EW".

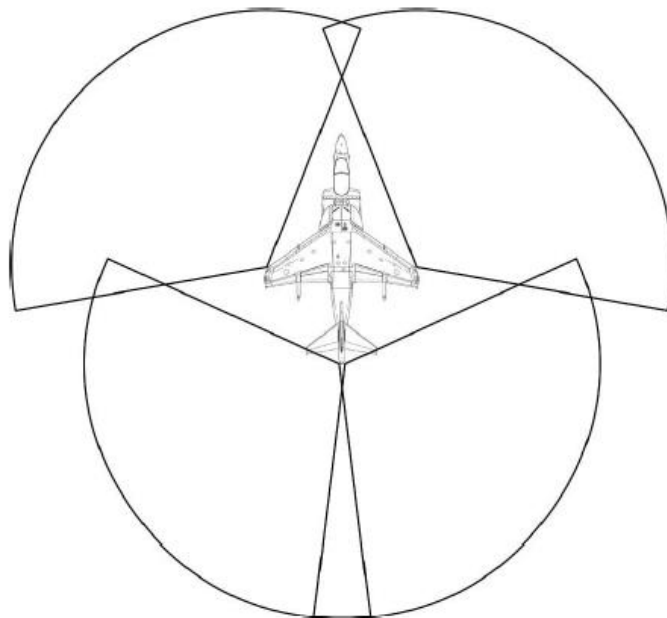

RWR Coverage



MiG-21 radar is tracking you to your right

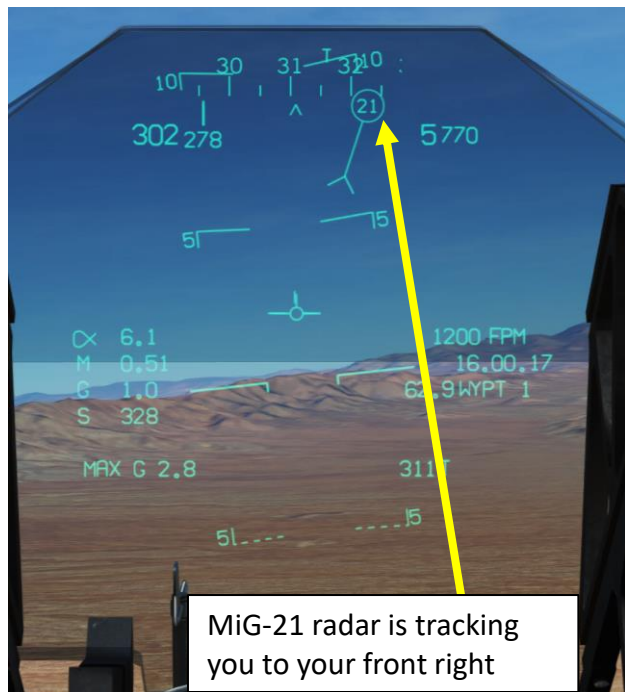

MiG-21 radar is tracking you to your front right



MiG-21 radar is tracking you to your aft right

**RWR (Radar Warning Receiver) Control Knob**  
OFF / ON / Volume

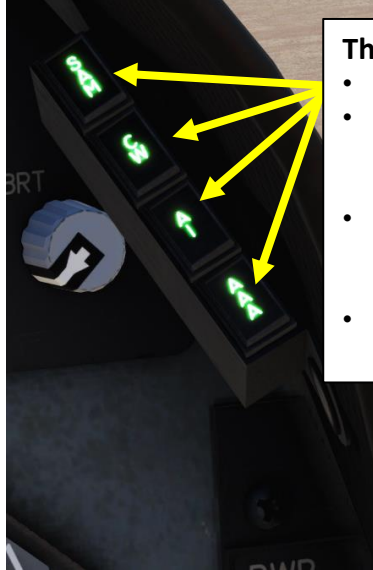

- Threat Lights**
- SAM: SAM launch detected
  - CW: Ground Tracking (Continuous Wave) radar is locked on aircraft
  - AI: Air Intercept radar is locked on aircraft (flashes if launch is detected)
  - AAA: Anti-Aircraft Artillery gun radar is locked on aircraft.

# AN/ALR-67(v) RWR (RADAR WARNING RECEIVER)

The "lollypops" indicate threat level for each signal:

- Short stem: Non-Lethal
- Dashed: Lethal
- Long Stem: Critical
- Long Stem with Arrow: Radar Lock
- Flashing long stem with arrow: Missile Launch

**LETHAL BAND:**  
Threats that are attacking the aircraft.

**CRITICAL BAND:**  
Threats that are safe for the moment

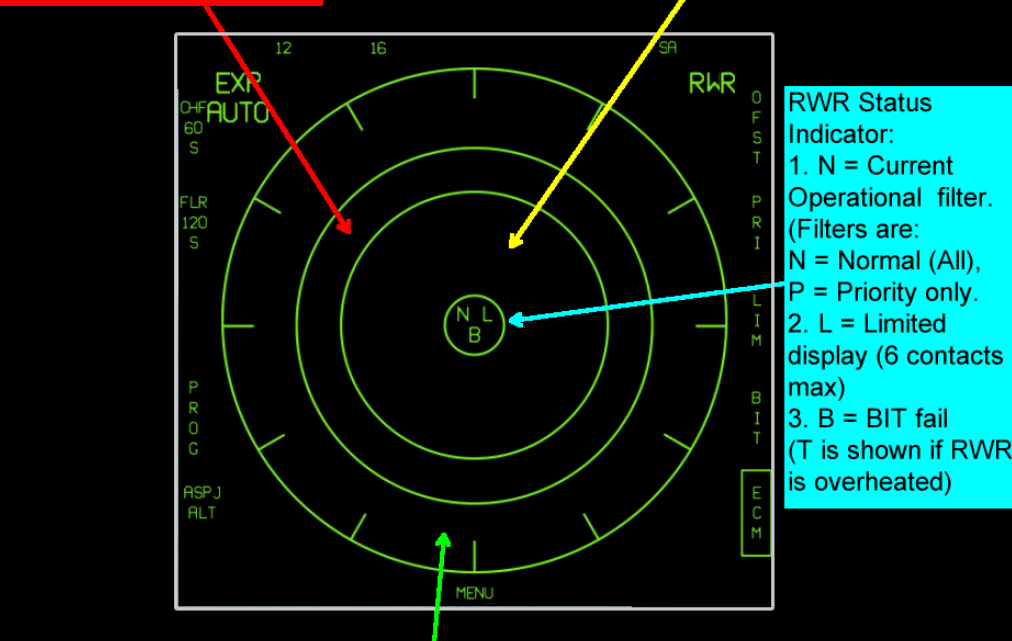

**NON-CRITICAL (SAFE) BAND:**  
Emitters that cannot harm the aircraft.  
Friendly emitters.  
Unknown emitters (unless they are threatening)

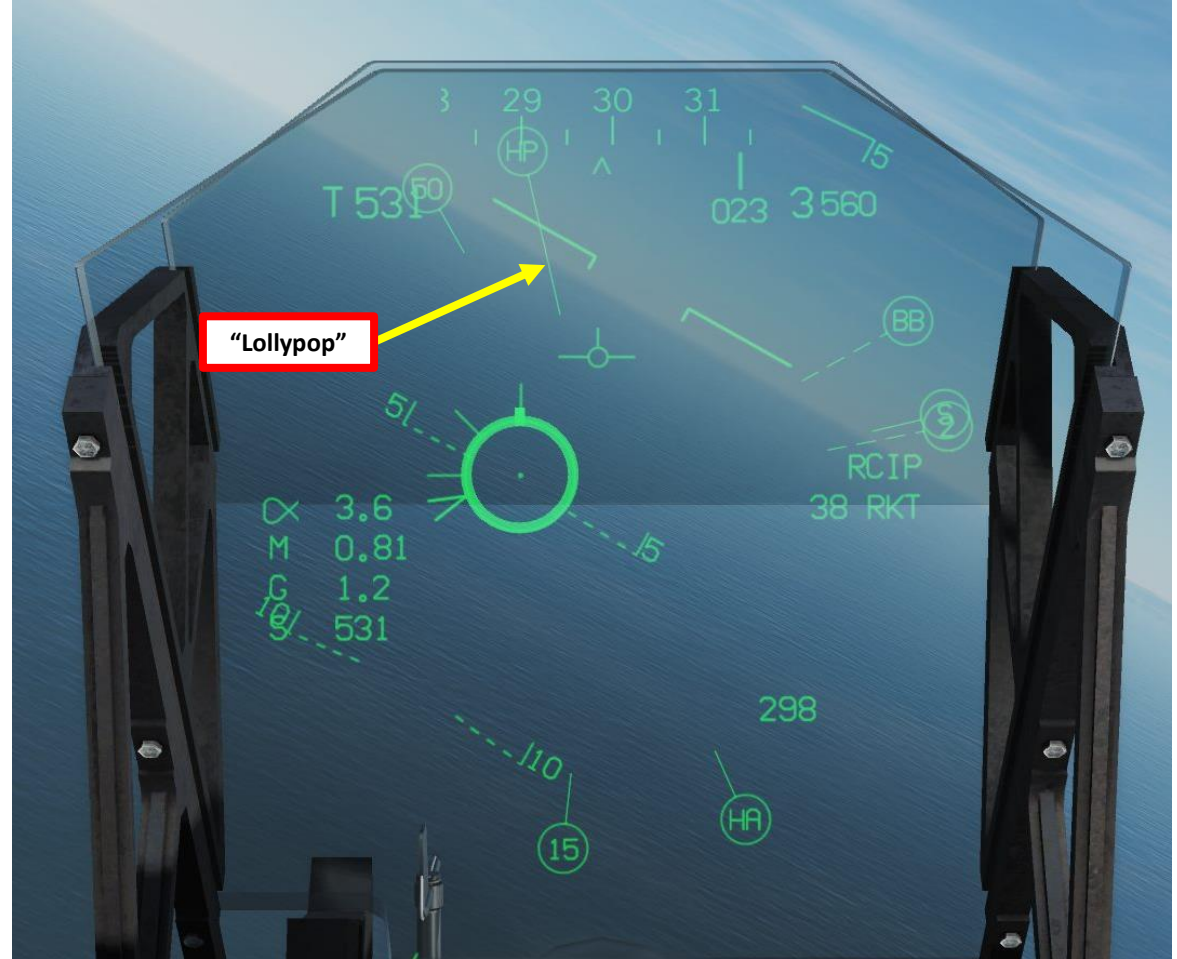

"Lollipop"

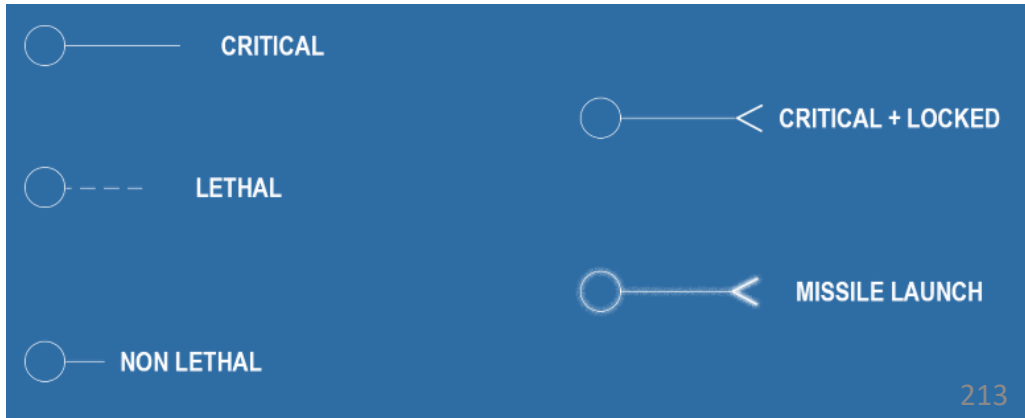

# AN/ALR-67(v) RWR (RADAR WARNING RECEIVER)





A steady symbol means that the radar is in search mode (in other words: not tracking you yet).

A flashing symbol indicates that the radar is supporting a missile that has been launched at you. You are about to receive a missile right up the arse. This is where you pop chaff, flares, ECM and start your evasive manoeuvres.

**Note:** “U” symbol stands for “Unknown”, which is sometimes attributed to ships.



Threat Symbology

-  Primary threat as dictated by the RWR
-  Threat is tracking your aircraft / Threat has locked your aircraft
-  Newest detected threat
-  Airborne threat

A symbol without a circle around it means that the radar is in search mode and is not tracking your airplane yet.

A symbol with steady circle around it means that the radar is tracking you, but the missile has not been shot at you yet.

A symbol with a flashing circle around it means that the radar is supporting a missile shot at you.

RWR	Name
3	S125 TR SNR
6	Kub STR 9S91
8	Osa 9A33
10	RLS 5H63C
10	S300PS TR 30N6
11	BUK LL
11	Buk LN 9A310M1
11	F-111
12	RLS 9C32 1
12	S300V 9A82
12	S300V 9A83
13	C-130
13	Strela-9A35M3
14	F-14
15	F-15
15	Tor 9A331
16	F-16
17	C-17
18	FA-18
22	Tu-22M3
23	MIG-23
24	Su-24
25	MiG-25P
29	MIG-29
29	Su-27
29	Su-33
30	Su-30
31	MiG-31
34	Su-34
39	Su-39
40	Spruance
48	Vinson
49	Perry
50	A-50
52	B-52
76	IL-76
78	IL-78
95	Tu-95
A	Gepard
A	Vulcan M163
A	ZSU 23 4 Shilka
AE	Ticonderoga
AN	AN-26B
AN	AN-30M

RWR	Name
AV	AV-8B
B1	B-1
BB	S300PS SR 64H6E
BD	RLO 9C15MT
BJ	Tu-160
CD	Bobruisk
CD	Bora
CS	S300PS SR 5N66M
DE	Dog Ear
DT	Osa
E2	E-2C
E3	E-3
E6	EA-6B
F2	F-2
F4	F-4E
F5	F-5E
GR	Roland rdr
HA	Hawk SR ANMPQ 50
HK	Hawk TR ANMPQ 46
HN	Grozny
HN	Orel
HN	Skory
HP	Albatros
HS	RLO 9C19M2
KC	KC-10
KC	KC-135
M2	Mirage
PP	Veter
PS	Molniya
PT	Patriot STR ANMPQ 53
RO	Roland ADS
S	EWR 1L13
S	EWR 55G6
S	S125 SR P 19
S3	S-3
S6	Tunguska 2S6
SC	Ametyst
SD	Buk SR 9S18M1
SW	Kuznecov
T2	Moscrow
TP	Neustrash
TP	Rezky
TS	Azov
Tu	Tu-142

List made by .408-X~RAY

# COUNTERMEASURES – CHAFF & FLARES (EXPENDABLES)

## Dispenser Pods

An important note about chaff and flares is that individual dispenser pods can be set on the ground by the ground crew by opening the kneeboard (RSHIFT+K), then pressing the right keys to cycle between chaff and flare pods (i.e. RSHIFT+RALT+1 will cycle the Top Front Left dispenser between 30 flares and 30 chaff).

Keep in mind that the engine needs to be OFF when performing these changes.

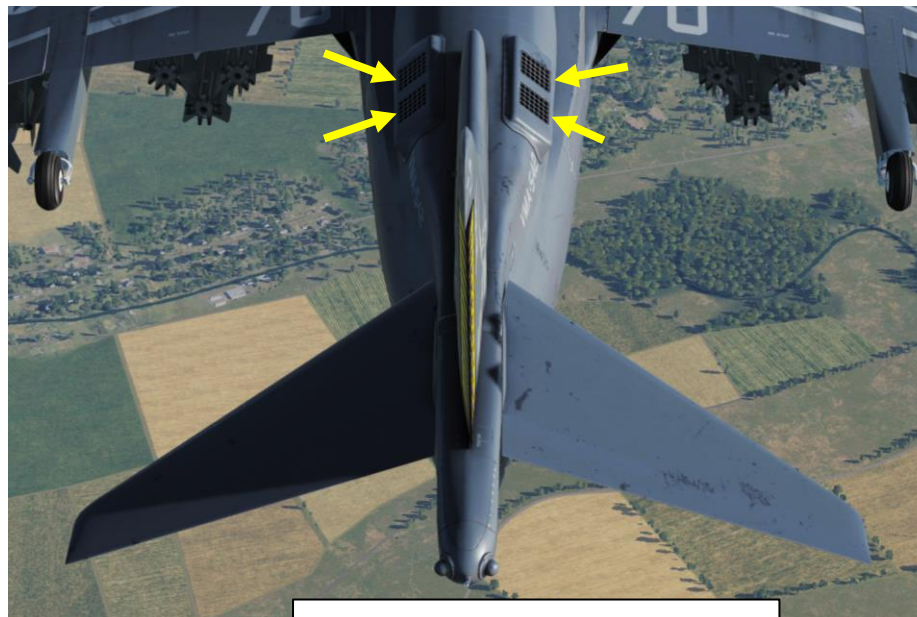

Countermeasure Dispenser Pods



### AV-8B NIGHT ATTACK WORKSHEET

GAU-12 Gun Pod:  
Gun Ammo:  
FF Rocket Fire Mode: **SINGLE**  
RS + RA + [0]  
AN/AVS-9 NVG Case:  
RS + RA + [9]

**WARNING:**  
VALUES CAN ONLY BE  
MODIFIED WHEN THE  
ENGINE IS OFF

STATION	1	2	3	4	5	6	7
WEAPON	---	---	---	DECM	---	---	---
NUMBER	0	0	0	1	0	0	0

**ECM Dispenser Pod:**

- 1. Top Front Left: 30 FLARES RS + RA + [1]
- 2. Top Front Right: 30 FLARES RS + RA + [2]
- 3. Top Rear Left: 30 CHAFF RS + RA + [3]
- 4. Top Rear Right: 30 CHAFF RS + RA + [4]
- 5. Bottom Left: 30 FLARES RS + RA + [5]
- 6. Bottom Right: 30 CHAFF RS + RA + [6]

**Initial Position**

- 1. Latitude: 41:55:52 N
- 2. Longitude: 041:51:21 E
- 3. Altitude: 65 FEET
- 4. Mag Var: 6.1 E

# COUNTERMEASURES – CHAFF & FLARES Release Procedure

1. Set Expendables Dispenser Control Knob to desired mode (preferably AUTO)
2. Set CHF and FLR release parameters to P (Program) or S (Single) by clicking the OSB next to their quantity in the EW (Electronic Warfare) page.
3. To dispense chaff or flares, use the ECM DISPENSE AFT/FWD/RIGHT switches (8, 7 and 0 key bindings)
4. Flare & Chaff counters are available on the EW RWR page.

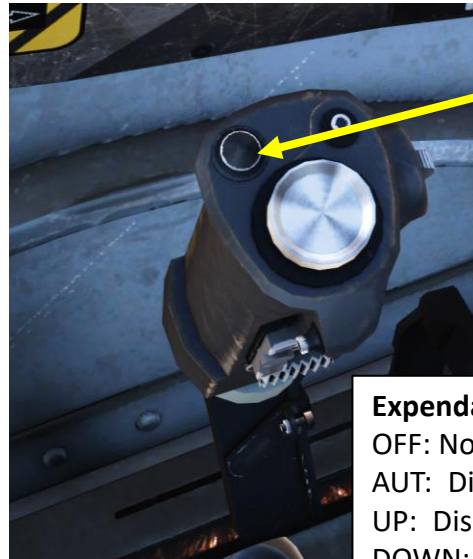

**Expendables Dispenser Control Knob**  
 OFF: No Power  
 AUT: Dispenser selected automatically  
 UP: Dispensers on top of aft fuselage used first  
 DOWN: Dispensers on bottom of aft fuselage used first  
 RWR: Option not available

**ECM (Electronic Countermeasure) Dispense Switch**  
 AFT = Dispenses Chaff  
 FWD = Dispenses Flares  
 LEFT = Mini Jammer Engaged (Not Functional)  
 RIGHT = Dispenses all countermeasure types



P = Program, S = Single

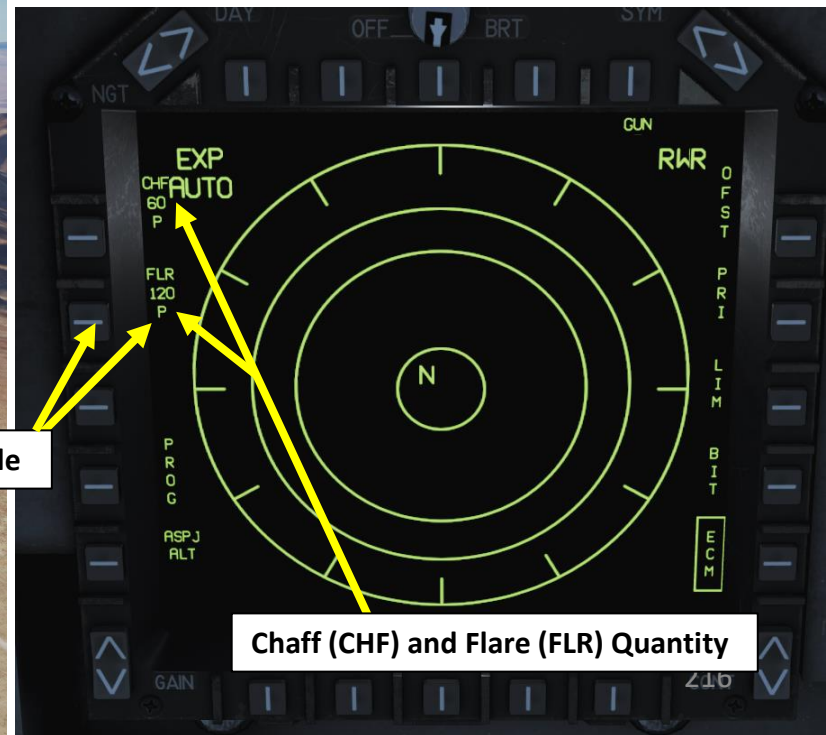

Chaff (CHF) and Flare (FLR) Quantity

# COUNTERMEASURES – CHAFF & FLARES

## Countermeasure Programs

Countermeasure release programs can be modified via the EW page. Access the Countermeasures PROG (Program) page by going in the main MPCD menu, selecting the OSB next to “EW” and then selecting the OSB next to PROG. You can then select if you want to program Chaff (CHF) or Flares (FLR).

Two parameters are customizable for **Flares** (needs the “P” mode next to Quantity):

- **QTY**: Quantity determines how many flare in total will be release per press of the ECM switch FWD.
- **INT**: Interval determines time between each flare (seconds).

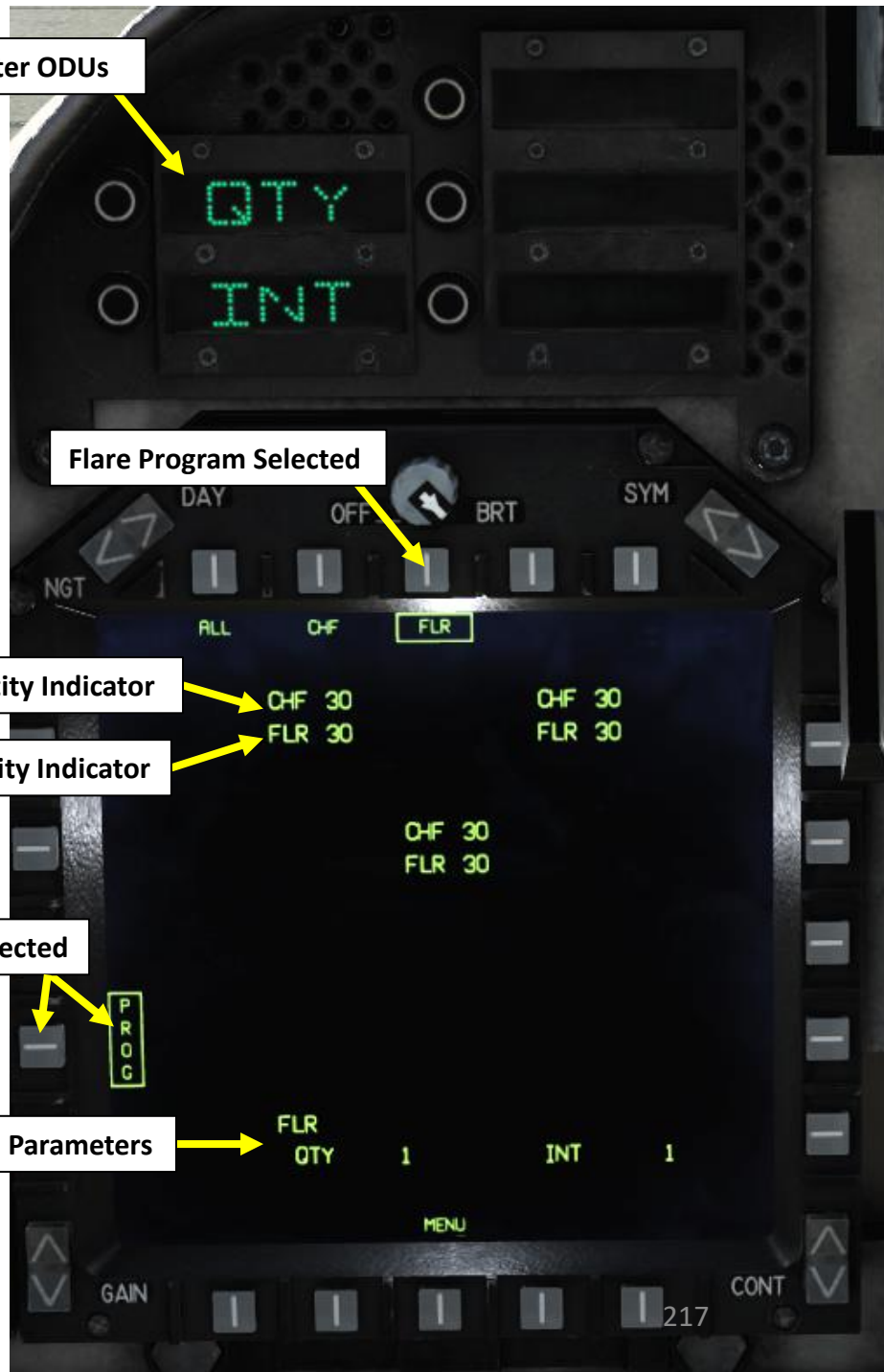
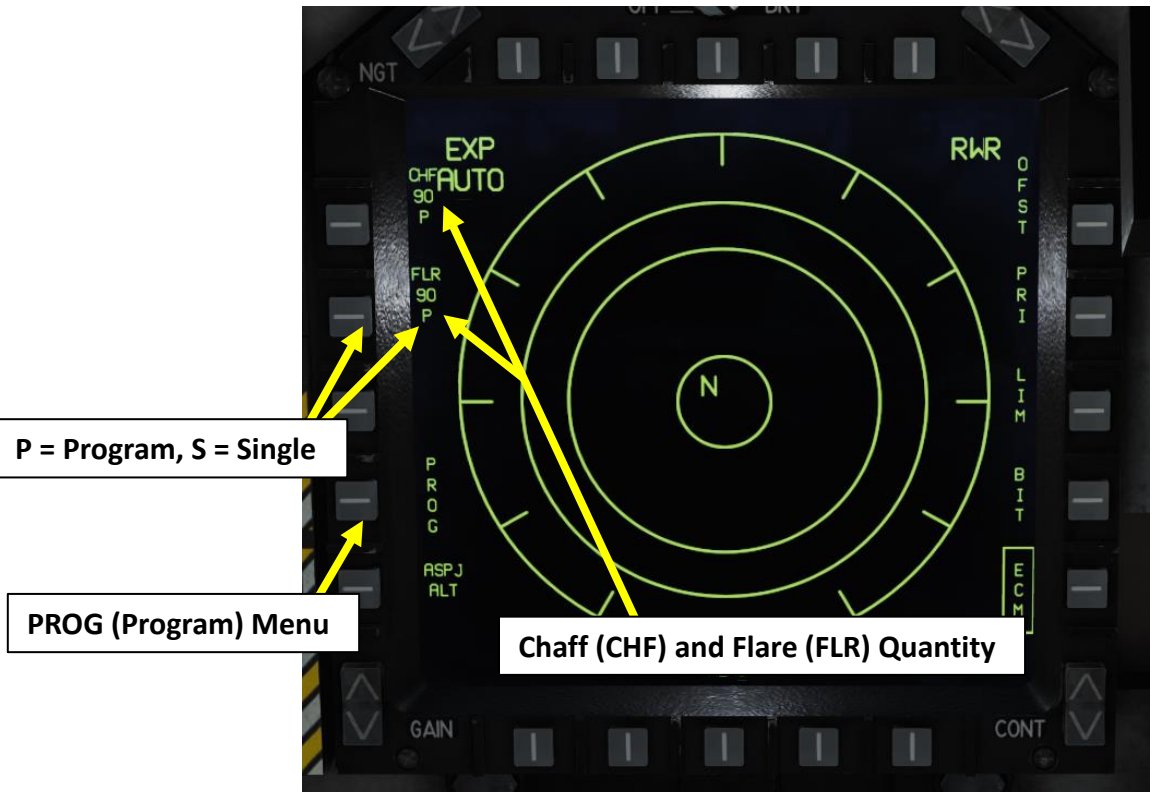

# COUNTERMEASURES – CHAFF & FLARES

## Countermeasure Programs

Four parameters are customizable for **Chaff** (needs the “P” mode next to Quantity):

- **BQTY**: Burst Quantity determines number of chaff released in each burst.
  - NUM parameter lets you set desired number of chaff
  - CONT parameter continues to release chaff until they are depleted
  - RND parameters randomly dispenses between 1 and 6 expendables in each burst
- **BINT**: Burst Interval determines time that will pass between release of each chaff in the given burst. Can be set between 0.1 and 1.5 sec.
- **SQTY**: Salvo Quantity. Each salvo is a full burst cycle, so the number of chaff released at the set interval for the burst option.
- **SINT**: Salvo Interval. Interval between the salvos. Can be set between 1 and 15 sec.

Example:

BQTY 3 / BINT 0.5 / SQTY 3 / SINT 5

Upon ECM switch press, 1 chaff will be released every 0.5 sec. 5 seconds later, three more chaff will be released with 0.5 sec interval. Another 5 seconds later, three more chaff will be released every 0.5 sec.

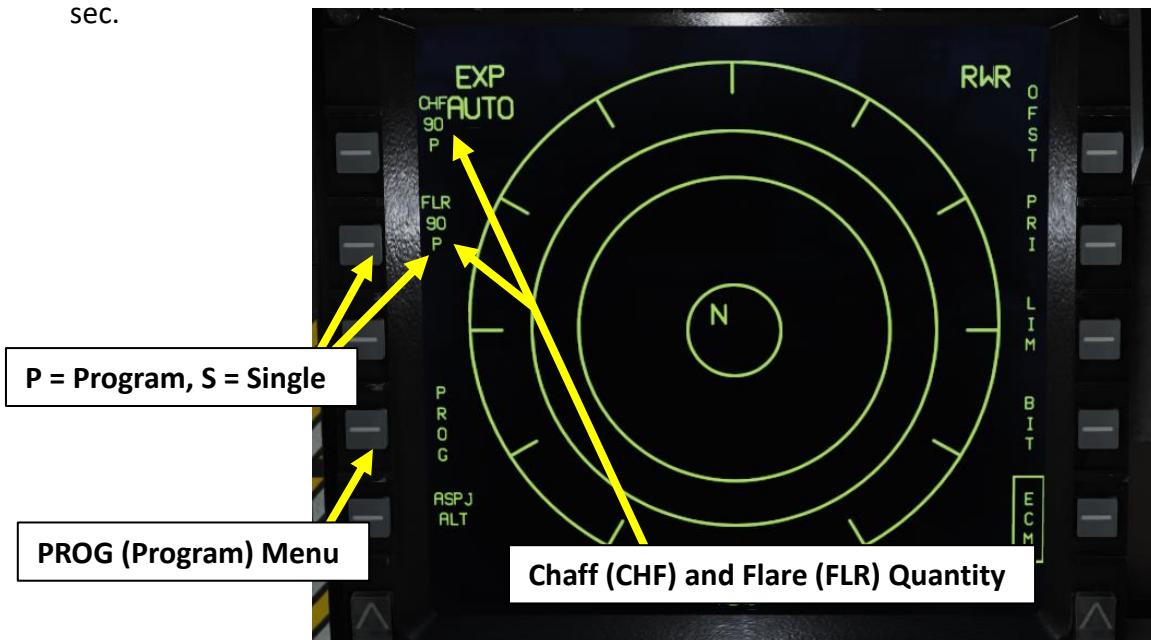

Chaff Parameter ODUs

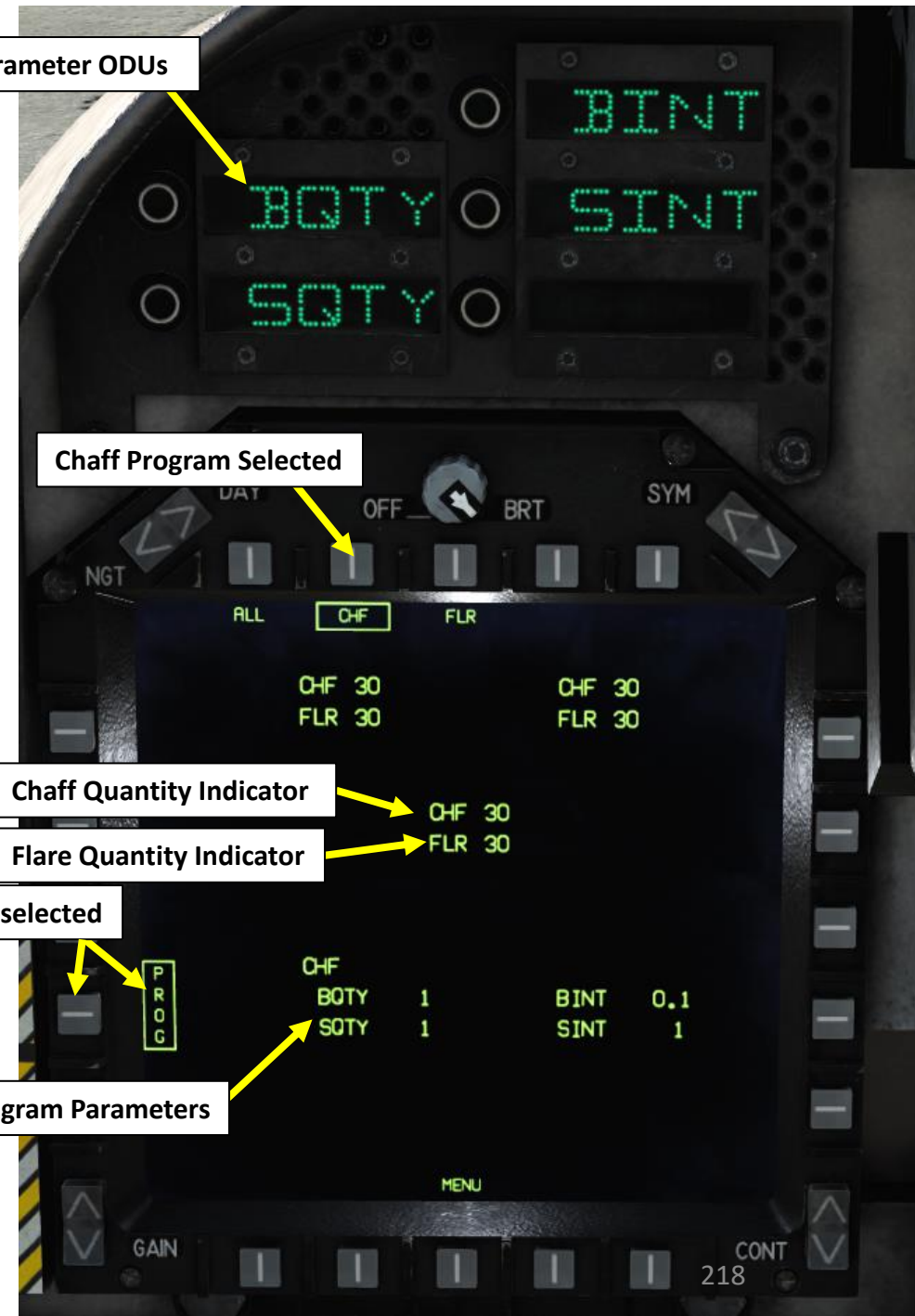

# COUNTERMEASURES – CHAFF & FLARES

## Countermeasure Programs

To modify a parameter of the program:

1. Select PROG page
2. Select either CHF (Chaff) or FLR (Flare) release program
3. Select parameter that you want to modify with ODU (Option Display Unit) buttons. In our case, we will choose Burst Quantity (BQTY).
4. Choose any sub-parameter if required (we will choose NUM for Number of Chaff).
5. Enter the new value on the UFC scratchpad, then press “ENT”.

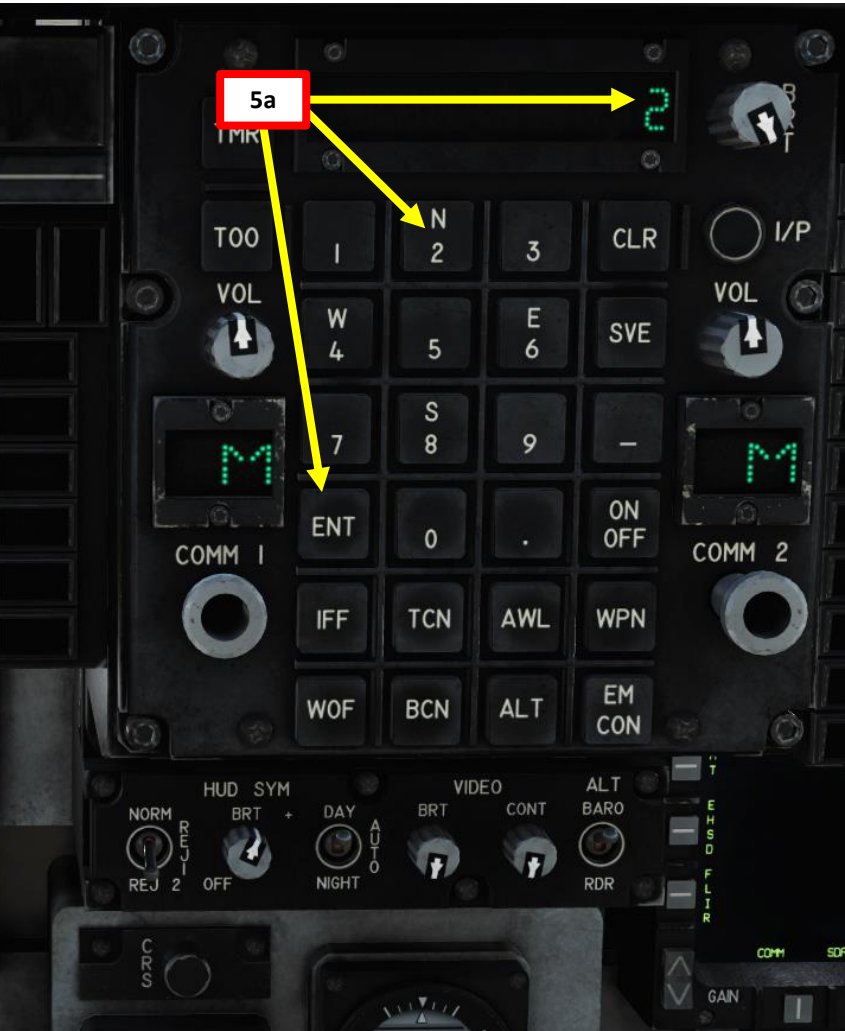
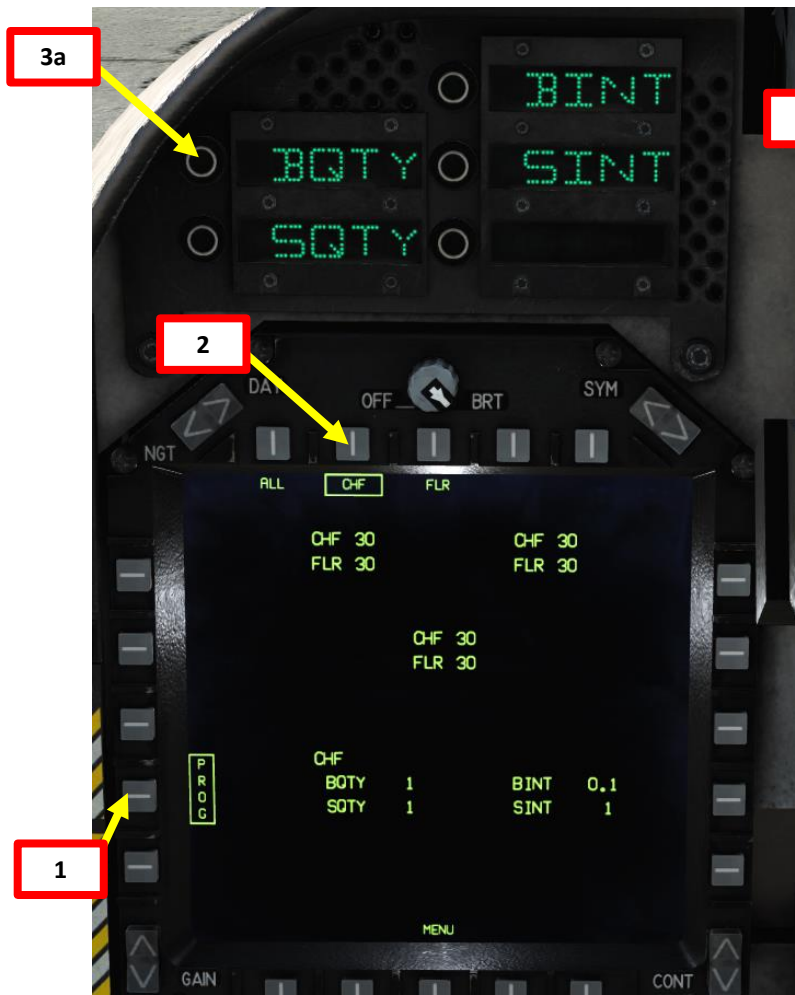

## AN/ALQ-164 DECM JAMMER POD (DEFENSIVE ELECTRONIC COUNTERMEASURES)

The DECM Jammer pod needs to be equipped on the ground and is externally mounted on the aircraft. It uses the ALQ-126B Charger Blue to counter pulse threats and the ALQ-162 Compass Sail to counter CW (Continuous Wave threats) like SARH (Semi-Active Radar Homing) missiles like the AIM-7 Sparrow.

The **Charger Blue** provides deceptive jamming against pulse-doppler threats in the E-J bands (2-18 GHz frequency range), which includes most radars on fighter aircraft from the 1960's. However, the Charger Blue does not have any capability against CW threats, therefore it is paired with a **Compass Sail**, which jams radar waves in the H-J bands (6-20 GHz frequency range) in a 120-degree beam width.

To use DECM, set the ECM Control Knob in the desired position (STBY when not needed, RCV if you want to avoid detection, and RPT when being actively tracked by a radar).



AN/ALQ-164 DECM Jammer Pod



### ECM (Electronic Countermeasure) Dispense Switch

- AFT = Dispenses Chaff
- FWD = Dispenses Flares
- LEFT = Mini Jammer Engaged (Not Functional)
- RIGHT = Dispenses all countermeasure types



### ECM (Electronic Countermeasure) Control Knob

- OFF: Removes power to DECM pod
- STBY: Powers DECM pod but does not emit signal
- BIT: DECM pod Built-In Test
- RCV: Smart Standby (pod emits based on signal received)
- RPT: Continuous jamming signal (repeat)

### DECM Status Messages

- **CW NO GO:** DECM Compass Sail Continuous Wave jammer is nonfunctional
- **P NO GO:** DECM Charger Blue pulse jammer is not functional
- **P JAM:** DECM Charger Blue pulse jammer is active and emitting
- **CW JAM:** DECM Compass Sail continuous wave jammer is active and emitting

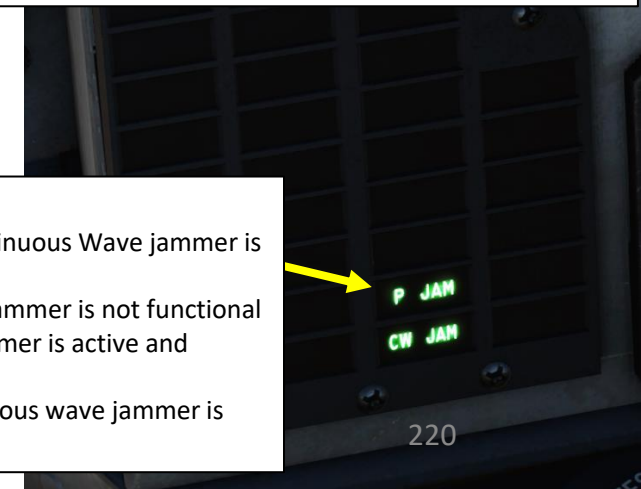

# ARC-210 RADIO - INTRO

The ARC-210 radio provides transmission and reception of amplitude and frequency modulated (AM & FM) on frequencies ranging from 30 MHz to 399.975 MHz.

The Harrier has two radios installed: COM1 and COM2. They are independent and have 26 preset channels each. The preset frequencies are set in the mission editor.

You can control the radio through two interfaces: the Up-Front Control (UFC) and through the ACNIP and V/UHF Radio Set Control (RCS). The radio has 2 operating modes: through UFC (Upfront Control) or MANUAL (through the ACNIP and RCS). You can toggle between UFC and MANUAL mode with the MODE switch on the ACNIP panel. Take note that the MANUAL mode is primarily used as an emergency mode for in-flight failures of the UFC.

V/UHF Radio Control Mode Switch

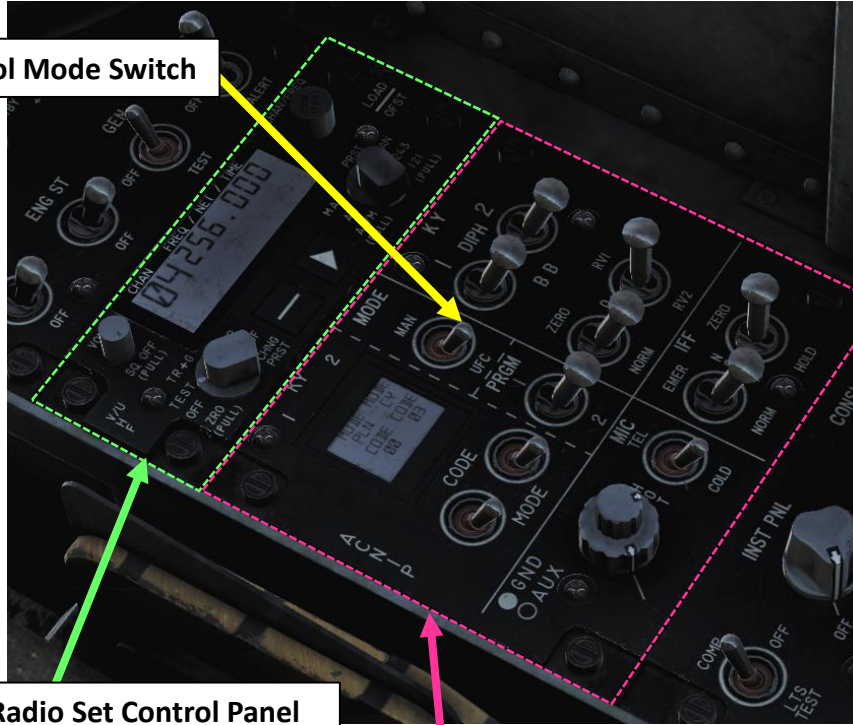

V/UHF Radio Set Control Panel

COMM1 & COMM2 Preset Frequencies



ACNIP (Auxiliary Communication, Navigation, Identification Panel)



UFC: Up Front Control

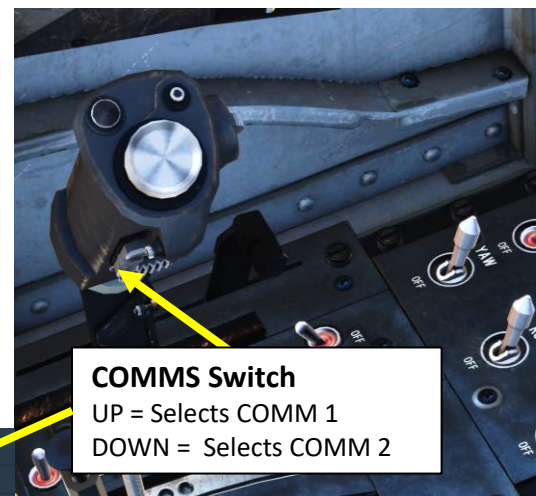

COMMS Switch  
UP = Selects COMM 1  
DOWN = Selects COMM 2

COMM AFT: Select COMM 2  
COMM FWD: Select COMM 1

HOTAS  
HOTAS

LCtrl + Num+  
LCtrl + Num-

JOY\_BTN3  
JOY\_BTN5

**ARC-210 RADIO – V/UHF RCS**

V/UHF Time (Not simulated)

V/UHF Network (Not simulated)

V/UHF Active Manual Frequency Selected

V/UHF Preset Channel Selected

V/UHF RSC Volume Control Knob

Turned: Volume  
Pulled: Squelch OFF

V/UHF RSC Channel Frequency Tuner

V/UHF RSC (Radio Set Control) Channel Frequency Mode Selector

- AJ/M: Not simulated
- AJ: Not simulated
- MAR: Selects one of 57 preset maritime channels. Not simulated
- PRST: CRS Switch changes selected preset channel.
- MAN: CRS Switch changes the frequency for the selected channel.
- 243: Turns on receivers for the 243.000 Mhz emergency frequency.
- 121: Turns on receivers for the 121.000 Mhz tactical frequency. Not simulated

V/UHF Ancillary Mode Switch

Positions cursor under various mode options. Used with ancillary mode pointer to select or deselect ancillary modes.

V/UHF Ancillary Mode Pointer

Positions pointer to select or deselect ancillary mode option defined by the – pushbutton.

V/UHF RSC (Radio Set Control) Channel Operational Mode Selector

- Pulled (ZRO): Not Simulated
- OFF: Turns RCS OFF
- TEST: Selects internal BIT (Built-In-Test).
- TR+G: Selects Receiver/Transmitter and GUARD receivers
- TR: Selects Receiver/Transmitter
- ADF: Automatic Direction Finder (not equipped on Harrier)
- CHNG PRST: Preset Channel Change

# ARC-210 RADIO – ACNIP

## V/UHF Radio Control Mode Switch

- **MAN:** Manual Mode (radio is controlled by the Radio Control Set panel)
- **UFC:** Up-Front Controller Mode (radio is controlled by the UFC and ODU, Option Display Unit)

## Radio Program 1/2 Switch

Selects which radio transmitter is active

## KY58 Secure Speech System Unit 1

Diphase/Baseband (DIPH/BB) Selector

## KY58 Secure Speech System Unit 2

Diphase/Baseband (DIPH/BB) Selector

## KY-58 Remote Variable Codes Load Switch

RV1: Not Simulated  
RV2: Not Simulated

## KY-58 Secure Speech System Unit #1 and Unit #2 Code and Mode Selected

The secure speech system is used for ciphering (coding) or deciphering (decoding) audio routed through the KY-58 cipher unit No. 1 (KY-1) or KY-58 unit No. 2 (KY-2).

## KY58 Cipher Zero Norm Switch

IFF (Identify-Friend-or-Foe) Zero/Hold Switch (Not Simulated)

KY-58 Unit #2 Code/Mode Switch (Not Simulated)

IFF (Identify-Friend-or-Foe) Emergency/Normal Switch (Not Simulated)

KY-58 Unit #1 Code/Mode Switch (Not Simulated)  
Used to select a desired KY58 operating mode and code

ICS (Intercommunication System) Mic (Microphone) Operational Mode Switch  
TEL / HOT MIC / COLD MIC

ICS (Intercom System) Ground Volume Knob

ICS (Intercom System) Auxiliary Volume Knob  
Can be used to tune volume of aural warnings (i.e. Bitchin' Betty)

# ARC-210 RADIO - UFC

The UFC gives you access to the 26 preset channels of COMM 1 and COMM 2 radios.

To turn on radios, rotate the VOL knobs of COMM1 and COMM 2.

To change preset frequency, rotate the COMM1 or COMM2 Channel selector knobs.

To set a radio frequency manually on an existing preset frequency:

1. Left click on the desired COMM1 or COMM2 Channel Selector button to select it
2. Scroll mousewheel on desired COMM Channel Selector button to select desired Channel
3. Press the CLR (CLEAR) button on the UFC
4. Enter the desired frequency on the scratchpad
5. Press the ENT (ENTER) to overwrite the frequency.

To set radio options, press the ODU buttons (Option Display Unit) to toggle parameters for each option.

To transmit to either COMM1 or COMM2, use the "COMM AFT: Select COMM2" and the "COMM FWD: Select COMM1" bindings.

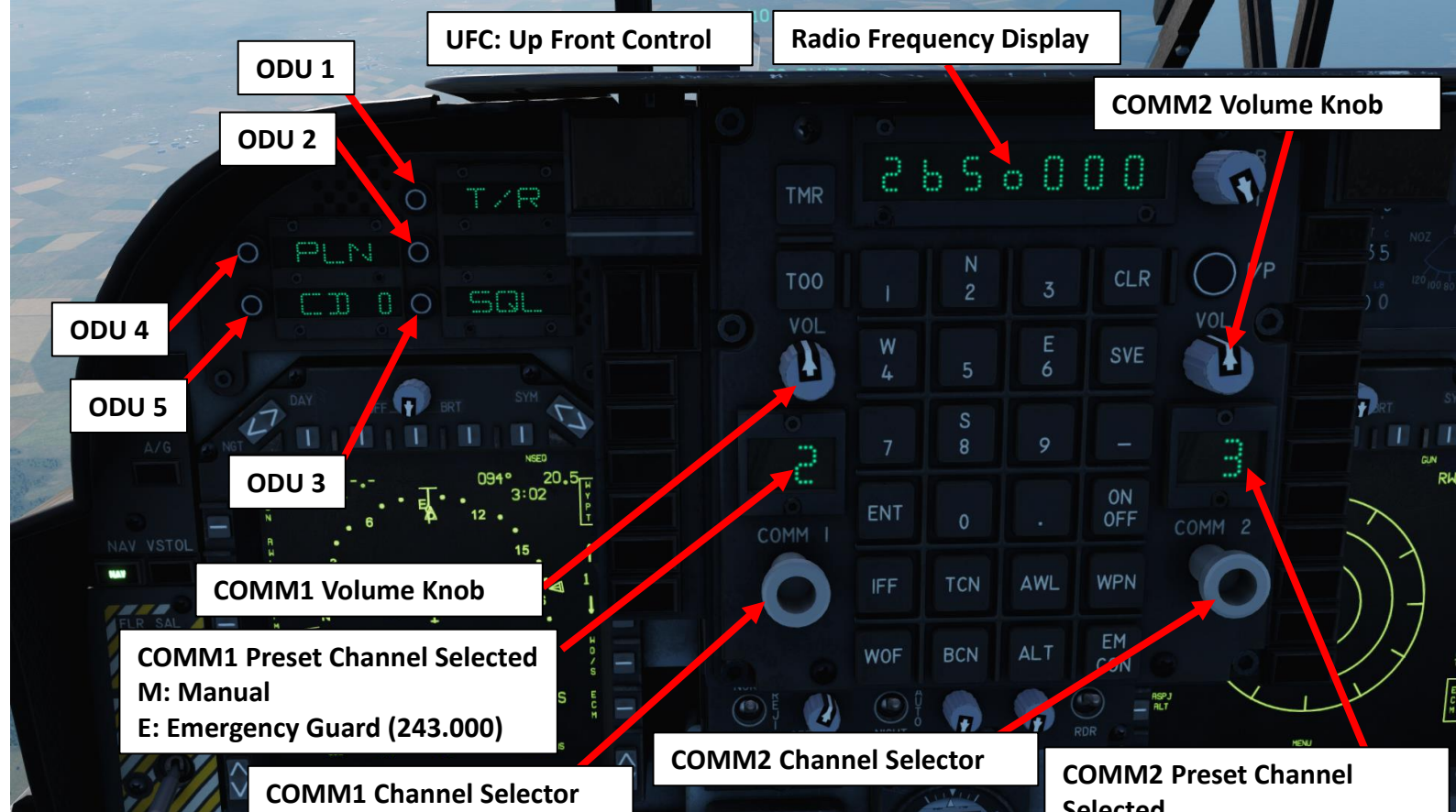

**Option Display Unit (ODU) 3**  
Toggles Squelch. ":" means Squelch is active.

**Option Display Unit (ODU) 1**  
T/R: Transmit/Receive  
TR+G: Transmit/Receive + Guard  
G: Guard

**Option Display Unit (ODU) 4**  
Toggles cipher modes: PLN (plain), CIPH (cipher) and DLY (delay). Not simulated.

**Option Display Unit (ODU) 2**  
Only avail when freq. between 225.000 to 400.000. Toggles AM or FM modulation.

**Option Display Unit (ODU) 5**  
Cipher code index to use when not in PLN (plain) mode. Not simulated since DCS does not have encrypted communications.

**COMM2 Preset Channel Selected**  
M: Manual  
E: Emergency Guard (243.000)

**COMM1 Preset Channel Selected**  
M: Manual  
E: Emergency Guard (243.000)

**COMMS Switch**  
UP = Selects COMM 1  
DOWN = Selects COMM 2

COMM AFT: Select COMM 2  
COMM FWD: Select COMM 1

HOTAS HOTAS  
LCtrl + Num+ LCtrl + Num-

JOY\_BTN3 JOY\_BTN5

**MPCD COMM PAGE**

From the Main Menu, you can access the COMM page, which will list all your preset frequencies.



Select COMM Page

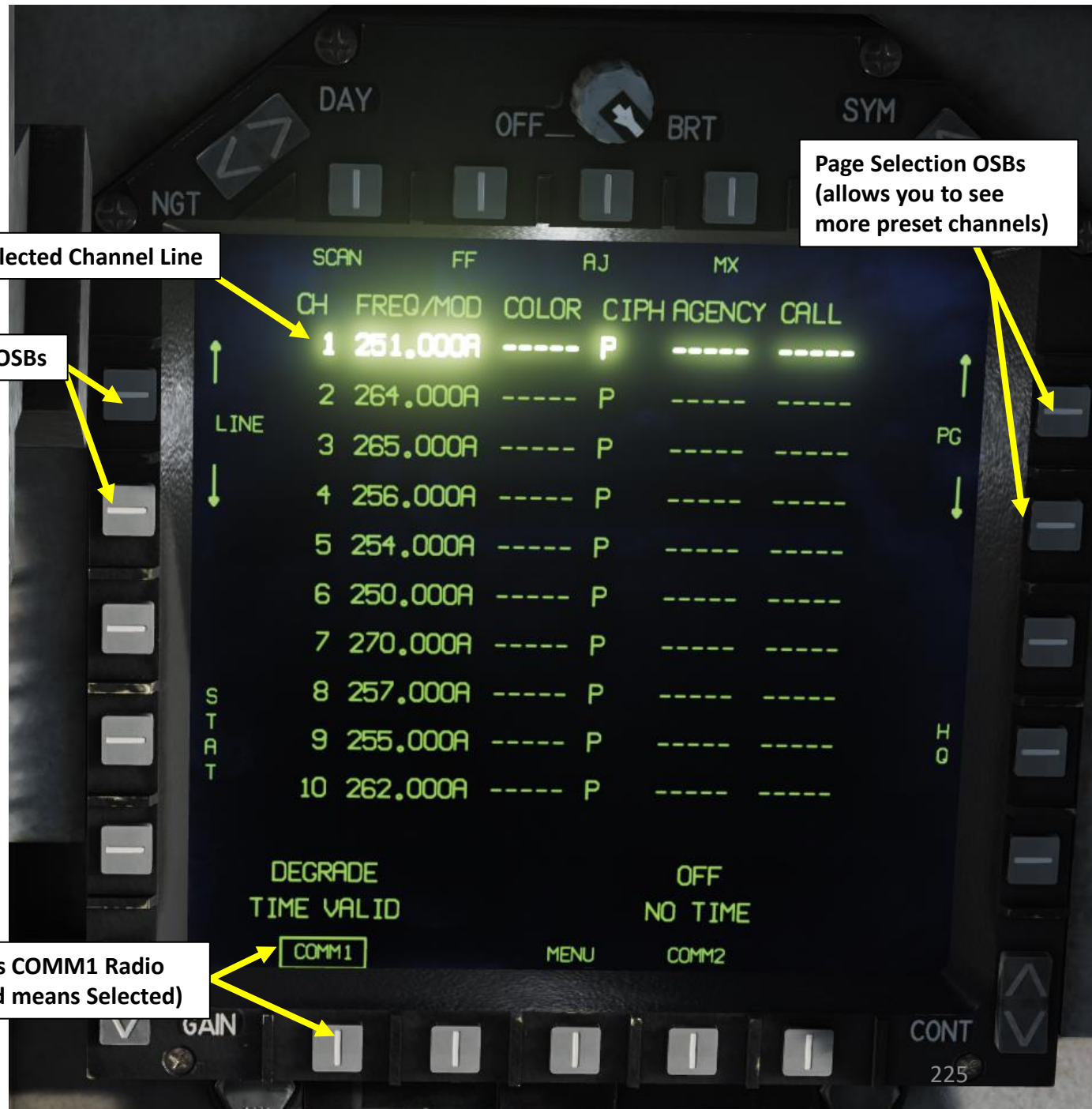

Selected Channel Line

Line Selection OSBs

Page Selection OSBs (allows you to see more preset channels)

Selects COMM1 Radio (Boxed means Selected)

# AFC: Automatic Flight Control

The autopilot of the Harrier is not very complicated to use.

1. Make sure you have all your Yaw, Pitch and Roll SAS switches ON
2. Set aircraft in desired altitude/attitude and make sure that the following conditions are respected or the autopilot will automatically disengage
  - You are not in a steep climb/descent (+/- 2000 ft per minute)
  - Airspeed must be greater than 160 kts
  - Your bank angle must be lesser than +/- 20 deg
  - Your pitch angle must be between -15 deg to +20 deg
3. Engage desired AFC Mode using the AFC switch (and the ALT HOLD switch if required)
4. You can use your trim controls while the autopilot is engaged to fine-tune your aircraft attitude.
5. You can disengage the SAAHS using the Emergency SAAHS Disconnect Switch or by simply setting the ALT HOLD & AFC switches OFF (AFT).

## AFC Modes

### AFC Switch Only - Engaged

AFC mode provides pitch attitude hold, roll attitude hold, and heading hold. You can see this as an "Attitude Hold".

### AFC Switch + ALT HOLD Switch - Engaged

ALT HOLD mode is pretty self-explanatory: the aircraft will provide an altitude hold. Keep in mind that you need to put yourself in level flight first, then engage the AFC switch, and finally set the ALT HOLD switch afterwards.

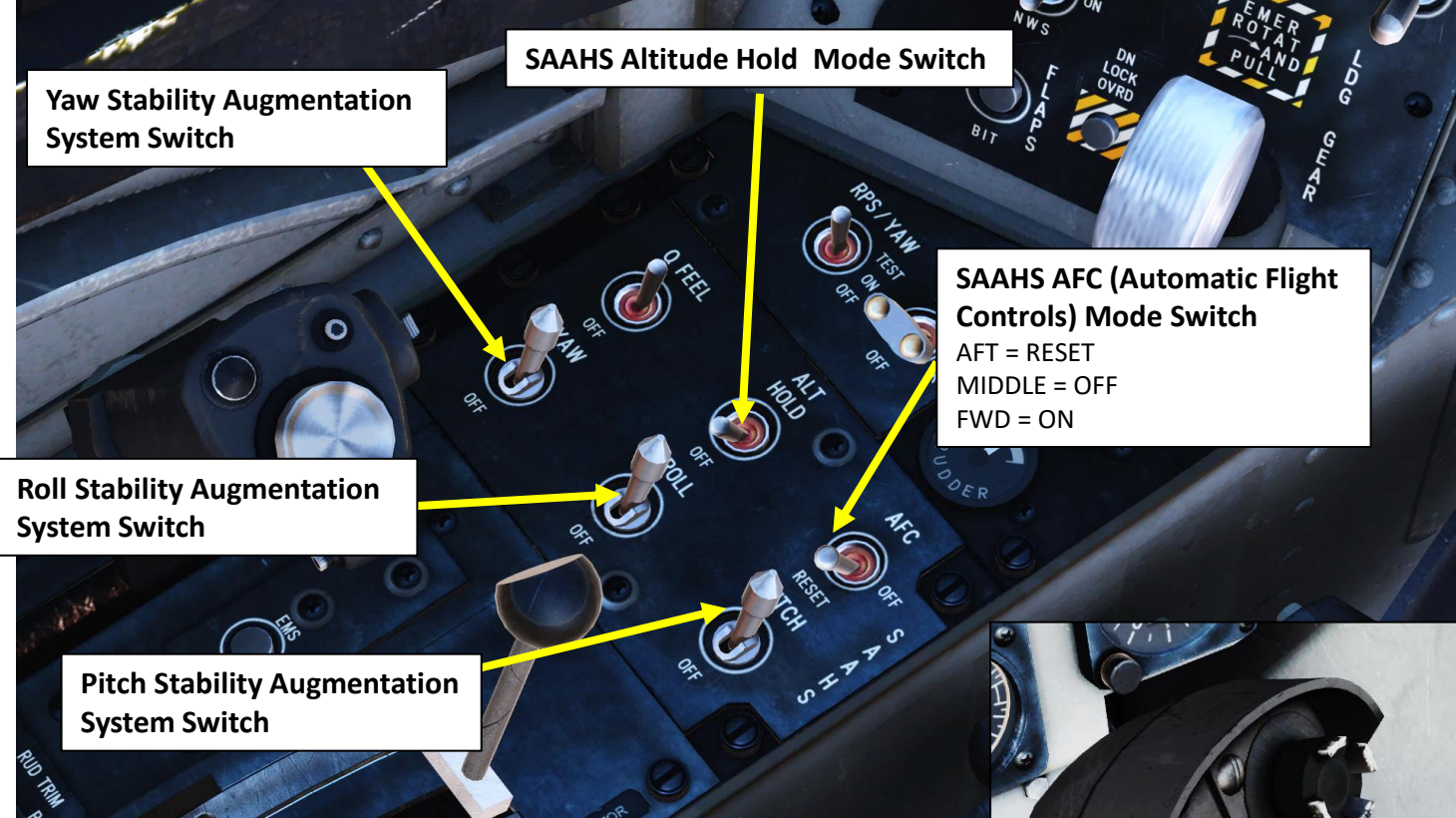

**SAAHS:**  
STABILITY AUGMENTATION & ATTITUDE HOLD SYSTEM

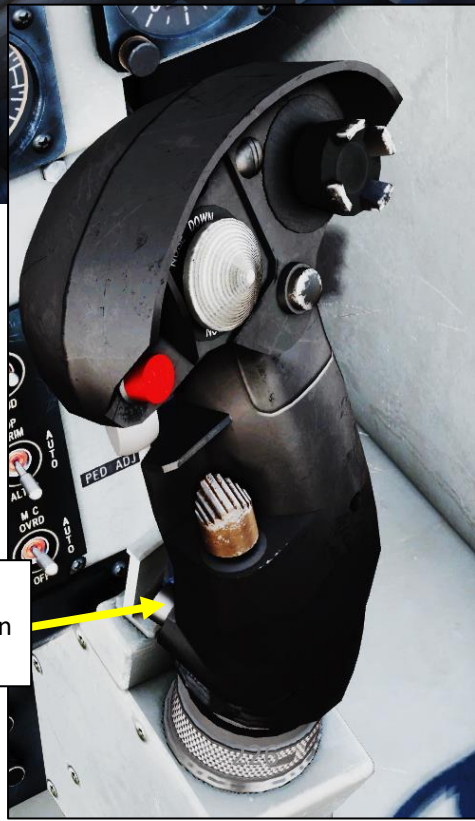

**Emergency SAAHS Disconnect Switch**  
Disengages SAAHS (Stability Augmentation and Attitude Hold System)

**NAVIGATION SECTION STRUCTURE**

- 1 – Navigation Introduction
- 2 – MAPM – Moving Map
- 3 – Steerpoint Types
- 4 – Waypoints
  - 4.1 – Waypoint Navigation
  - 4.2 – How to Add Waypoints
  - 4.3 – How to Edit Waypoints
  - 4.4 – How to Edit Waypoints with Moving Map & TDC
  - 4.5 – Waypoint Offset
- 5 – Markpoints
  - 5.1 – Markpoint Navigation
  - 5.2 – How to Add Markpoints
  - 5.3 – Using Markpoints
- 6 – Targetpoints
  - 6.1 – Targetpoint Creation
  - 6.2 – Waypoint Designate
  - 6.3 – Using Targetpoints
- 7 – TACAN Navigation
- 8 – AWLS/ILS Tutorial
- 9 – Bullseye

# 1 - NAVIGATION INTRODUCTION

Navigation in the Harrier is mostly done through the EHSD (Electronic Horizontal Situation Display), which is a top-down view that displays your heading and navigation aids such as TACAN (Tactical Air Navigation) beacons and waypoints entered before flight in the mission editor.

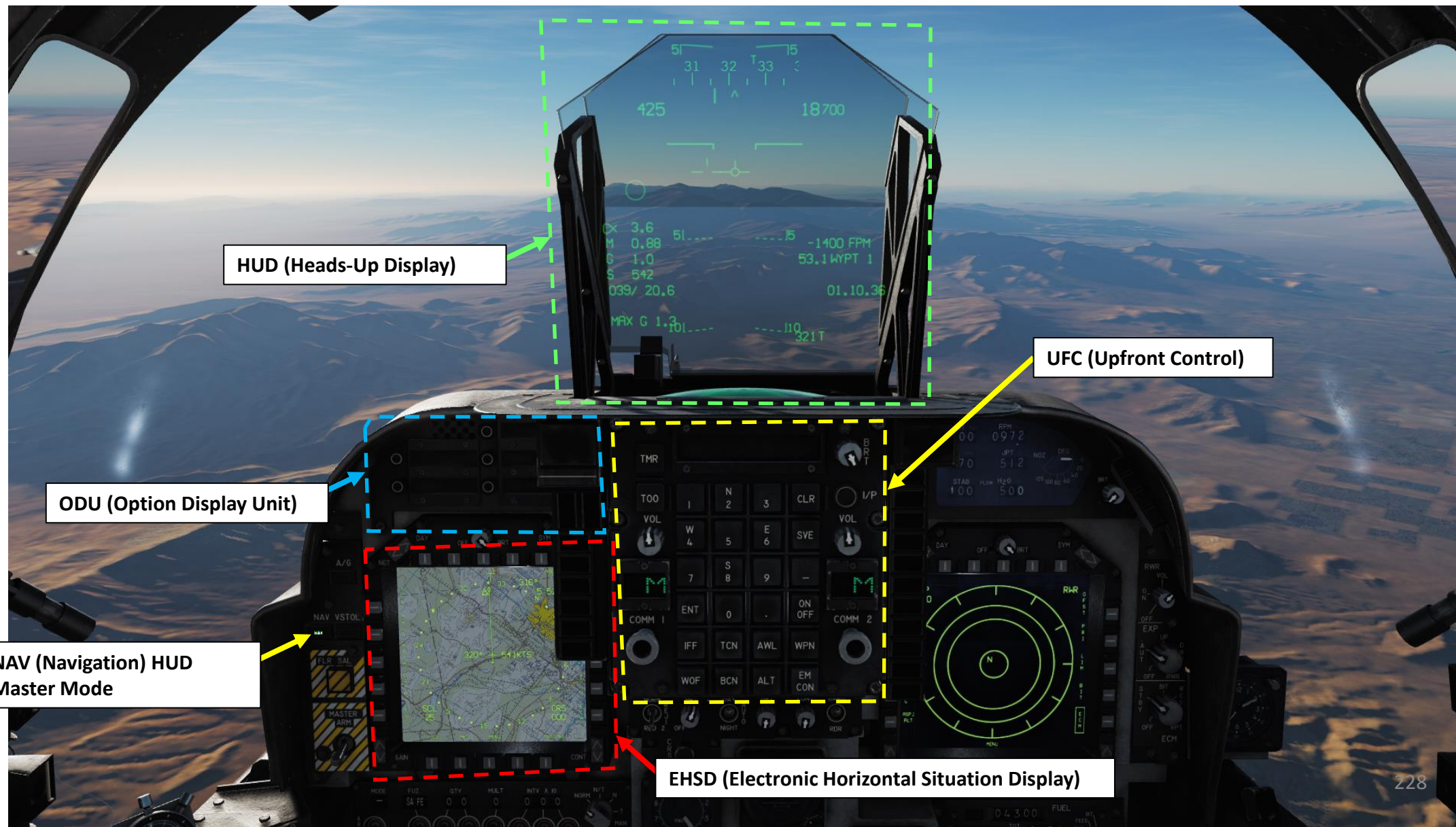

HUD (Heads-Up Display)

UFC (Upfront Control)

ODU (Option Display Unit)

NAV (Navigation) HUD Master Mode

EHSD (Electronic Horizontal Situation Display)

## 2 - MAPM: MOVING MAP

The Moving Map can be used to help you navigate. To turn it on:

1. Select the EHSD page on either MPCD
2. Press the OSB next to MAPM to select the Moving Map menu.
3. Press the OSB next to MAP to activate the Moving Map.
4. And that's it! Easy as pie.
5. Take note that the MAP-specific menus that appeared in step 3) will automatically revert back to the EHSD-specific menus after a short delay as shown in step 2).

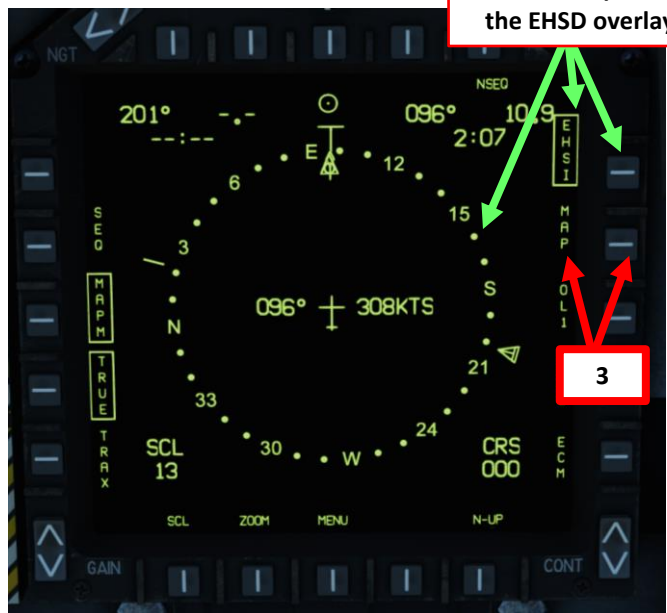
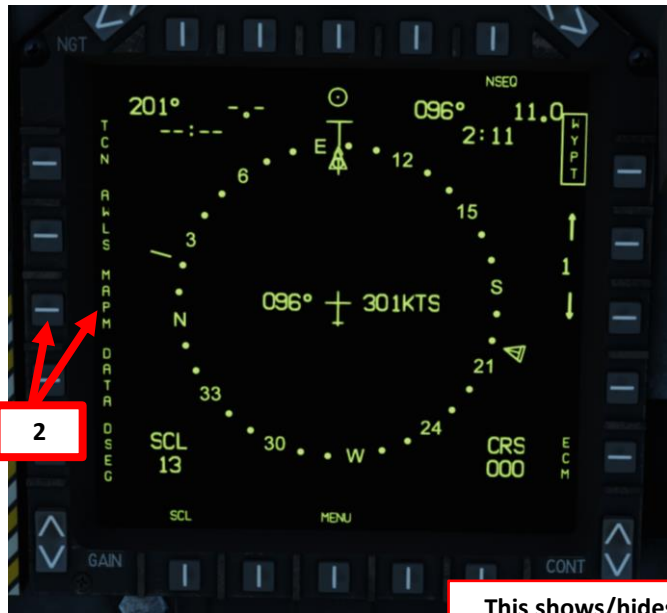

2 - MAPM: MOVING MAP

MOVING MAP (0 to 10 SECONDS AFTER MAP MENU SELECTED)

TRUE option will display True Track instead of Magnetic Track

TRAK option will display Ground Track Line

SCL option will change map scaling (100, 25, 13, 5, AUTO)

SEQ option will display waypoints and their numbers

ZOOM option magnifies map scaling by 2

EHSI option shows/hides the EHSI overlay

MAP option shows/hides moving map

N-UP option selects the NORTH IS UP or the TRACK IS UP (up is aligned with the aircraft heading) map orientation



2 - MAPM: MOVING MAP

MOVING MAP (MORE THAN 10 SECONDS AFTER MAP MENU SELECTED, AUTOMATICALLY REVERTED BACK TO EHSD MENU)



TCN selects the TACAN tracking mode

AWLS selects the All-Weather Landing System tracking mode

MAPM selects the MOVING MAP menu

DATA selects the Data display mode (information about tracked aircraft/waypoint/TACAN)

DESG is used for Steer to Point Designation

NSEQ option enables non-sequential waypoint navigation

Ground Track

Ground Speed (kts)

Aircraft (top down view)

2 - MAPM: MOVING MAP

MOVING MAP (DATA MENU)



GPS coordinates for tracked waypoint/TACAN/aircraft

Ground elevation for tracked waypoint/TACAN/aircraft

UTM coordinates for tracked waypoint/TACAN/aircraft

DECL: Declination Angle

MVAR: Magnetic Variation

Aircraft (top down view)

WYPT Centers Map on Selected Waypoint

DATA selects the Data display mode (information about tracked aircraft/waypoint/TACAN)

Bearing for tracked waypoint/TACAN/aircraft

A/C Centers Map on aircraft

Range for tracked waypoint/TACAN/aircraft

TCN Centers Map on selected TACAN

2 - MAPM: MOVING MAP

When Master Mode is set to NAV, you can choose if the aircraft position is based on the INS (Inertial Navigation System) or the GPS (Global Positioning System). Both the GPS and INS are coupled together, so in normal operation conditions it doesn't really matter. However, INS accumulates drift error and can eventually become inaccurate. GPS is more reliable, yet it relies on satellite data.



Aircraft position based on INS (Inertial Navigation System)



Aircraft position based on GPS (Global Positioning System)

### 3 - STEERPOINT TYPES

There are three main Steerpoint types use in the Harrier:

- **Waypoints**
  - Waypoints are pre-planned navigational points of reference for you to follow on route to your area of operation. You can create new ones, edit their coordinates and even create “Waypoint Offsets” if a target location is given to you with range and bearing information in relationship to an existing waypoint (i.e. Bullseye). Bullseye is a pre-determined point in space used as a reference point for flights to relay positions, used as a bearing and distance from Bullseye.
- **Markpoints**
  - Markpoints are used to "mark" a point of interest, whether flying over an interesting area or an enemy sighting. They can be selected, modified and offset just like regular Waypoints.
- **Targetpoints**
  - Targetpoints are used when designating a target with either the targeting pod, DMT (Dual Mode Tracker). This is used mainly to provide location reference for targets and weapon release cues. There can only be a single targetpoint, therefore each new targetpoint you create will overwrite the previous one. Take note that a targetpoint is created and memorized every time you press the Air-to-Ground Bomb Pickle Button and release a bomb in CCIP. This functionality is quite useful if you need to perform subsequent passes on a single target.

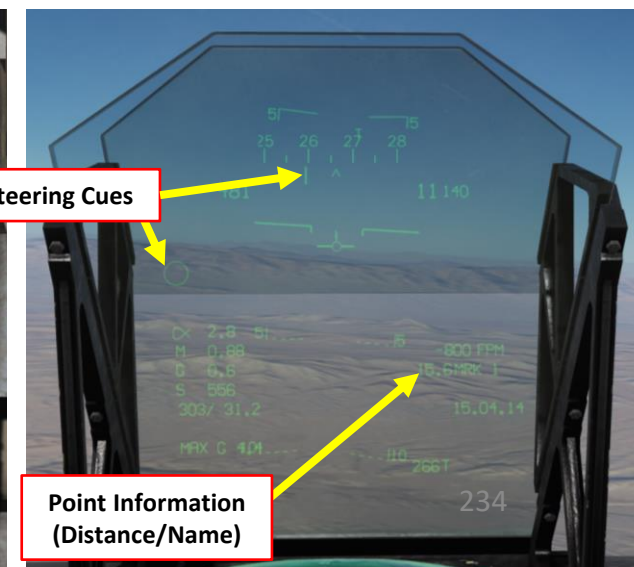
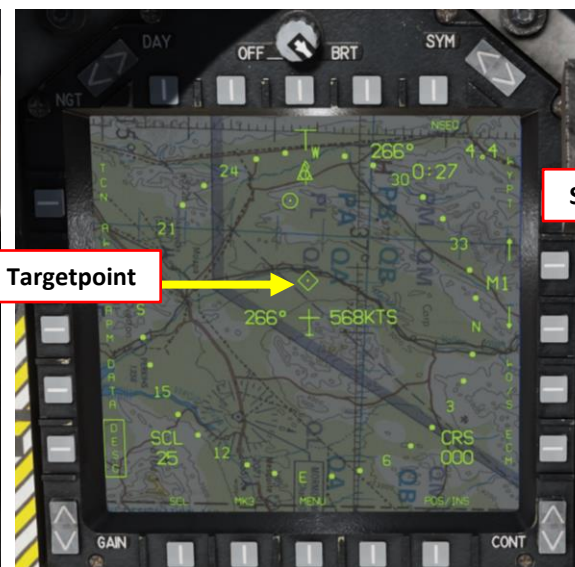
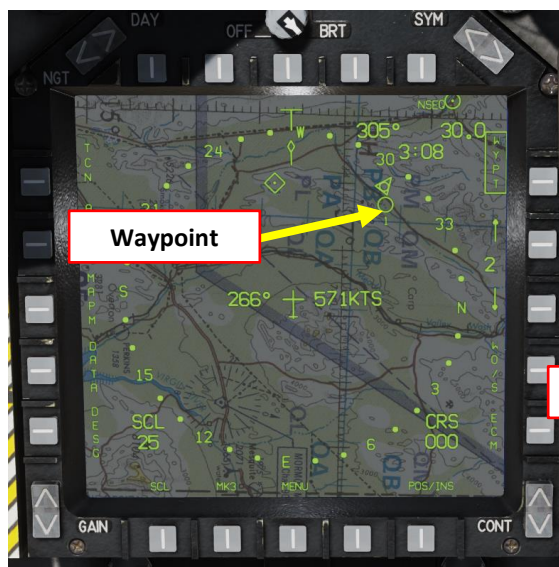

## 4.1 - WAYPOINT NAVIGATION

1. Select the EHSD page on either MPCD
2. Press the OSB next to WYPT to set tracking mode to WAYPOINT.
3. To select a waypoint, press the OSB (Option Select Button) to increment or decrement the waypoint number.
4. Make sure the HUD Master Mode is set to NAV to be able to track your waypoint directly from your HUD.
5. Check the previous MOVING MAP section to see how to display/remove the moving map

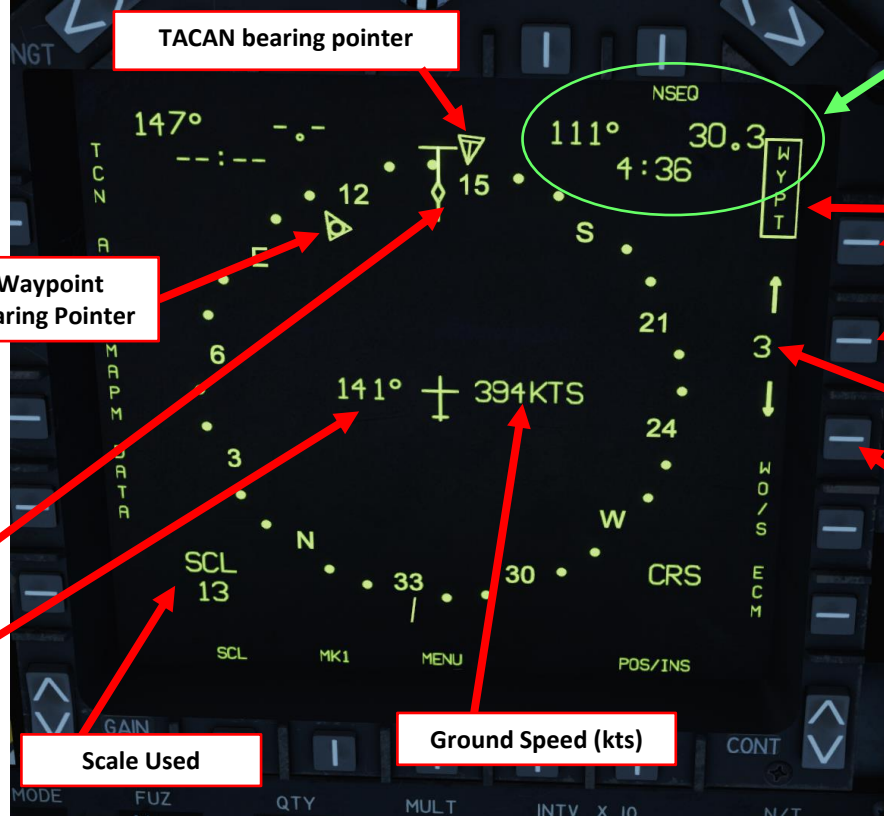

**Waypoint Data**

Bearing (degrees)	Distance (Nm)
Time-to-Go to Waypoint (minutes:seconds)	

**Waypoint Selected (Boxed)**    2

**Waypoint Increment OSB**    3

**Waypoint Selected (Waypoint 3)**    3

**Waypoint Decrement OSB**

**Aircraft ground track pointer**

**Ground Track (deg)**

**Scale Used**

**Ground Speed (kts)**

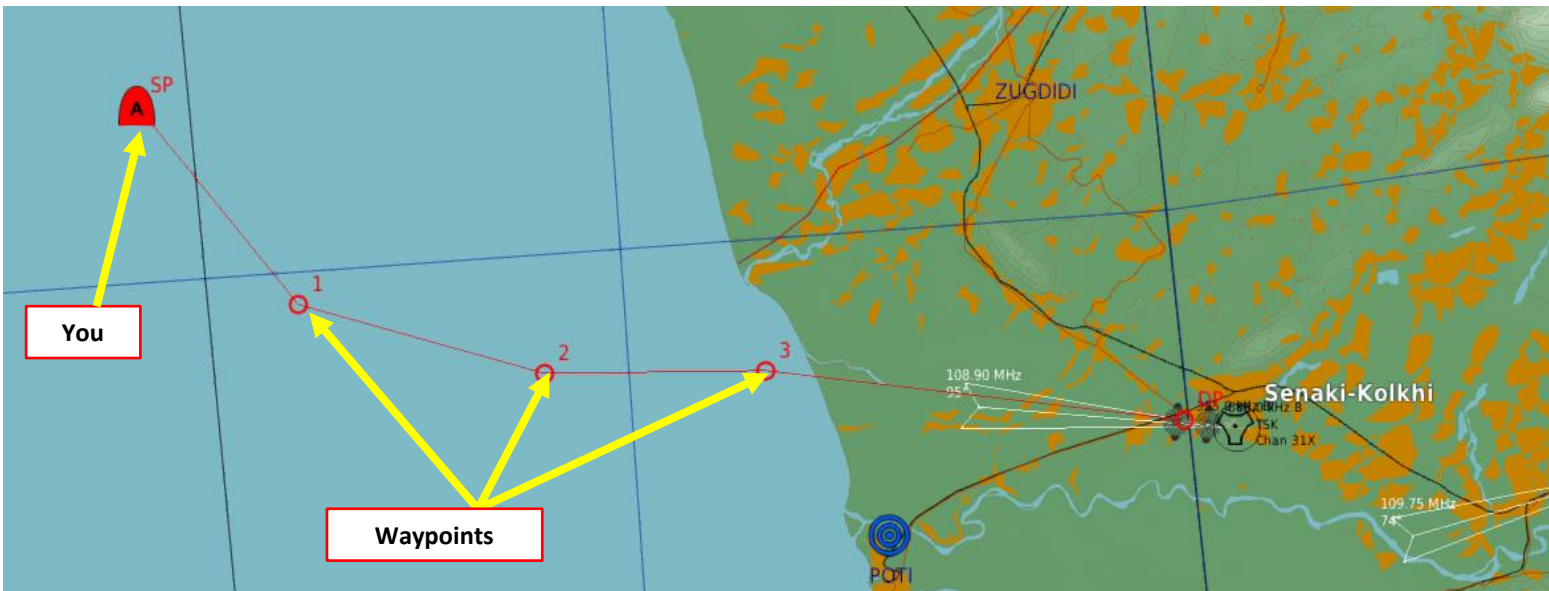

**4**



# 4.1 - WAYPOINT NAVIGATION

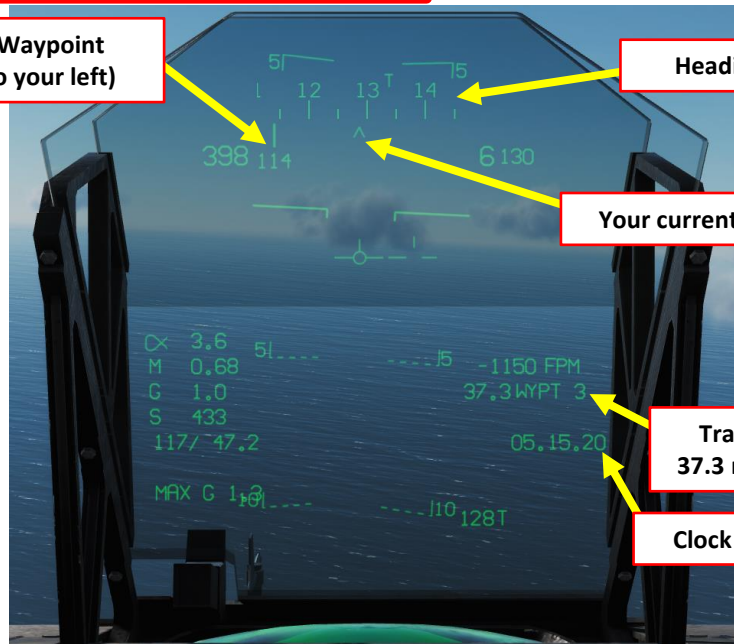

Selected Waypoint Bearing (to your left)

Heading Tape

Your current heading

Tracking Waypoint 3  
37.3 nautical miles away

Clock

Waypoint Heading (vertical bar) and your current heading (triangle) are now aligned. You are on course!

Waypoint Representation (Circle)

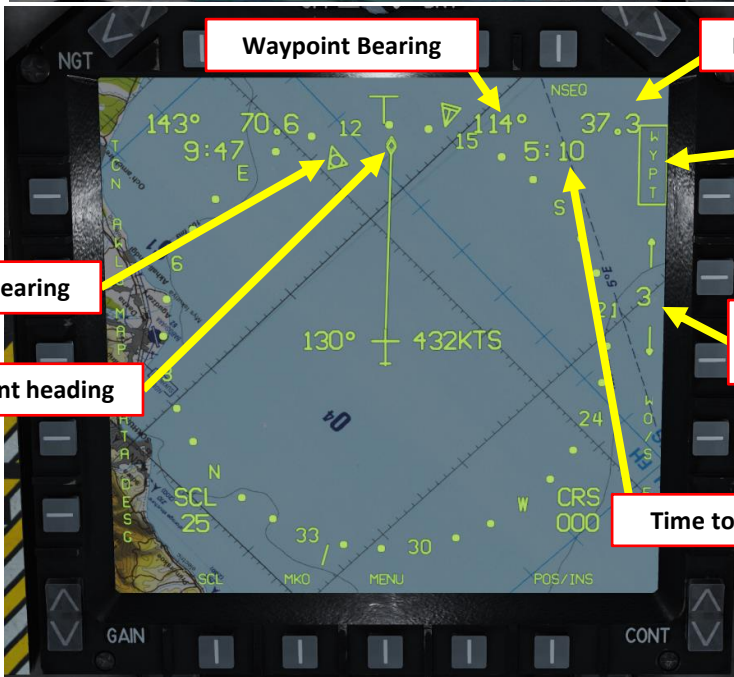
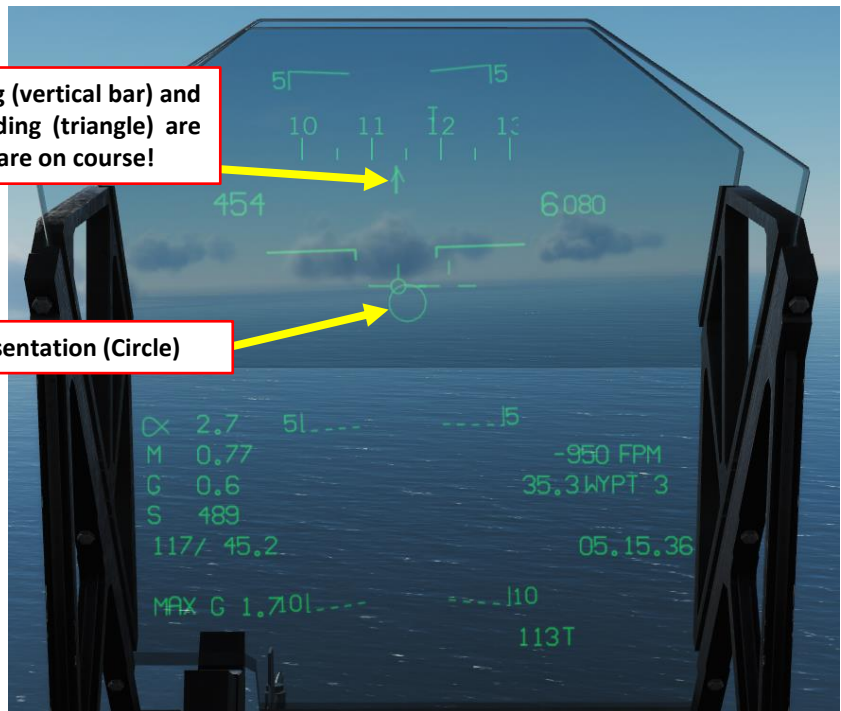

Waypoint Bearing

Distance to waypoint (nm)

WAYPOINT Selected

Waypoint Bearing

Your current heading

Tracking Waypoint 3  
37.3 nautical miles away

Time to waypoint

Waypoint Heading (triangle) and your current heading (bar) are now aligned. You are on course!

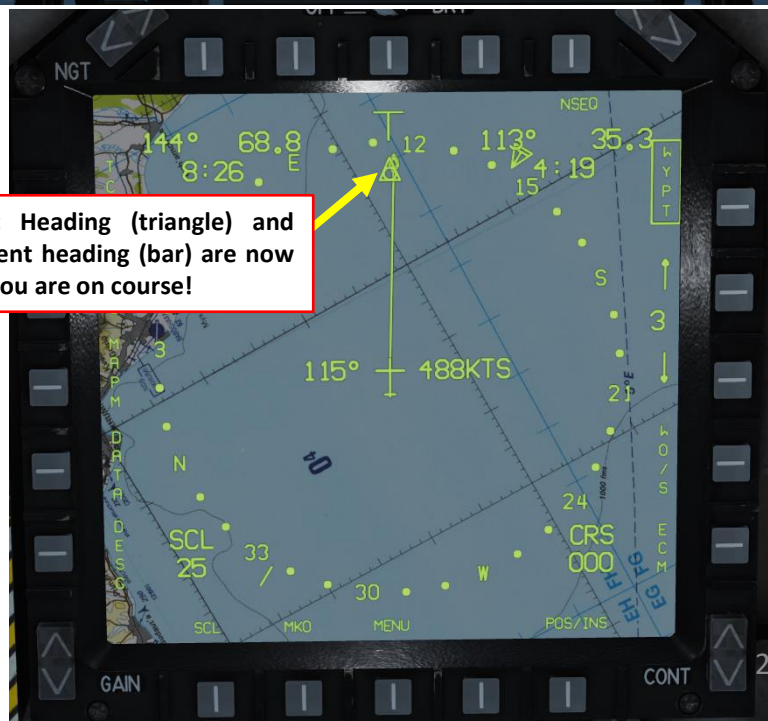

# 4.1 - WAYPOINT NAVIGATION

6. Note 1: you can also use the Course Setting Knob to set a course line to the selected waypoint.

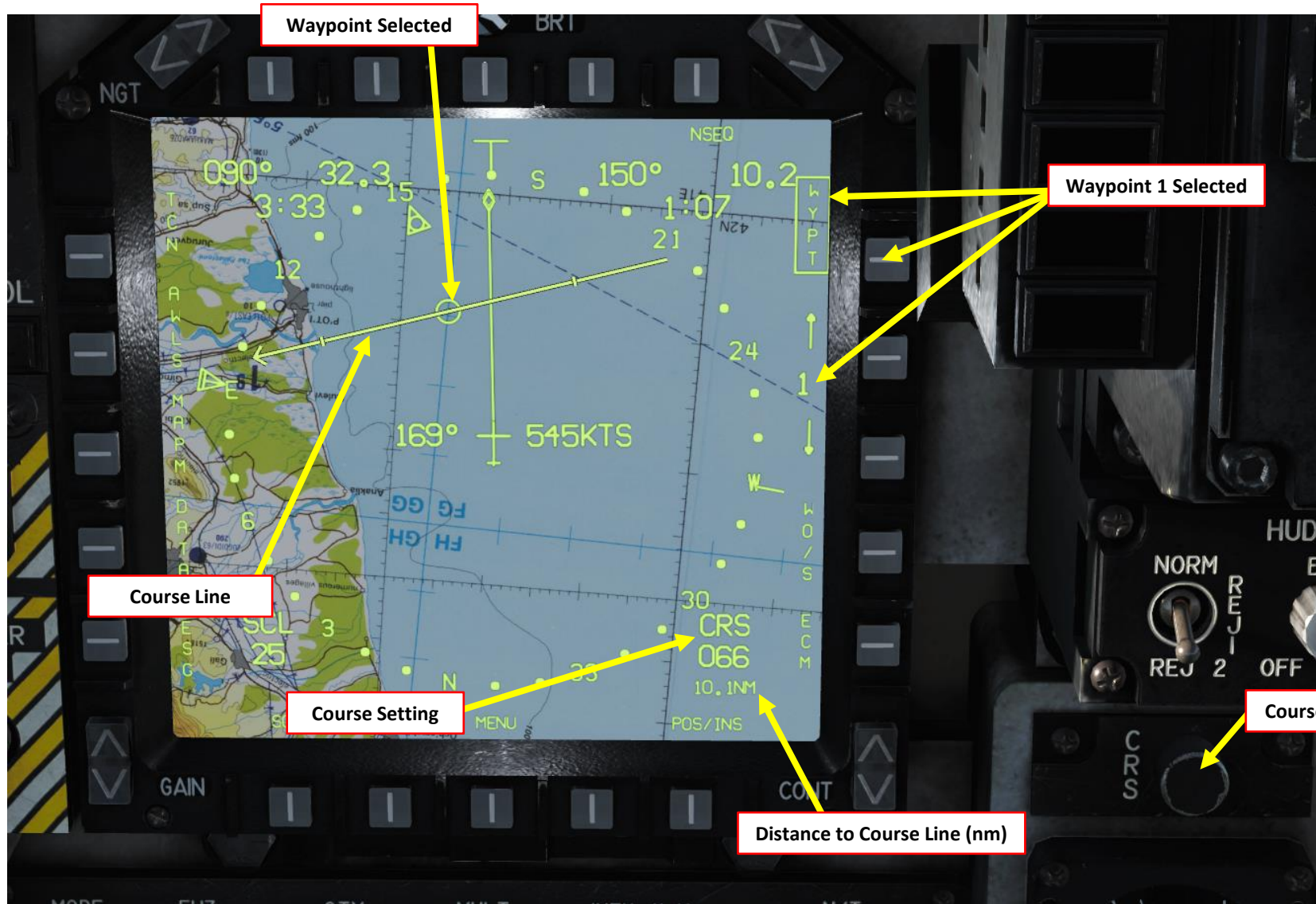

# 4.1 - WAYPOINT NAVIGATION

7. Note 2: you can cycle to the next waypoint by either:
- a) Using the OSBs next to the arrows
  - b) Pressing the "WP Increment", or "WINC" switch (Waypoint Increment, or "RWIn+W" binding) for less than 0.8 sec.
  - c) Pressing and holding the "WP Increment" switch for more than 0.8 sec, which will display the QA (Quick Access) menu. From there, you can select whatever steerpoint you want. As an example, to select Waypoint 3, press and hold the WINC switch, select the ODU next to WYPT (":"), then press "3" and "ENT" on the UFC scratchpad.

**Quick Access (QA) Menu ODUs**  
Waypoint, Markpoint and Targetpoint selectable



4.1 - WAYPOINT NAVIGATION

8. Note 3: you can display multiple waypoint symbols by pressing the OSB next to "MAPM", then selecting "SEQ" (Sequence, boxed when selected).

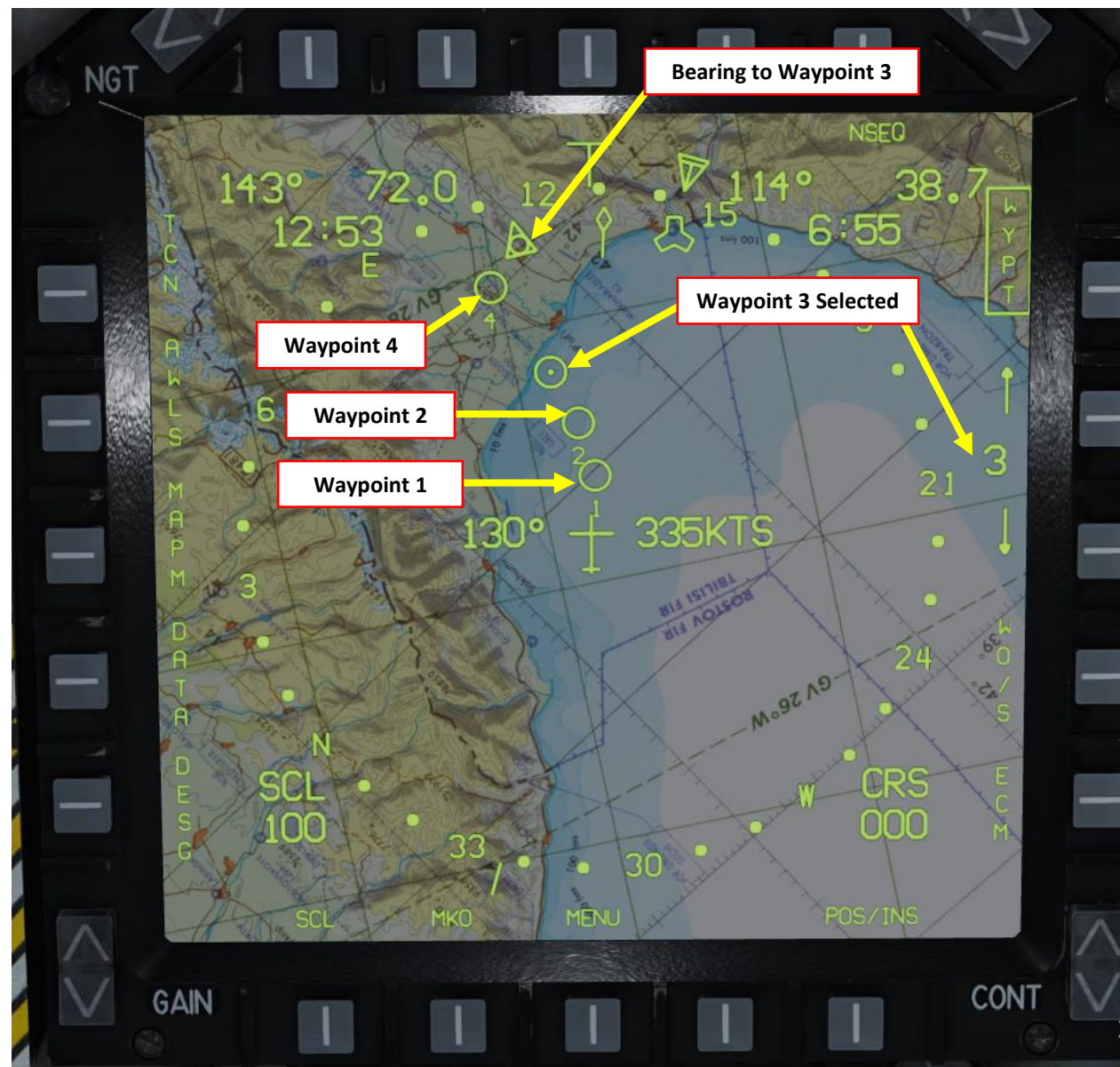
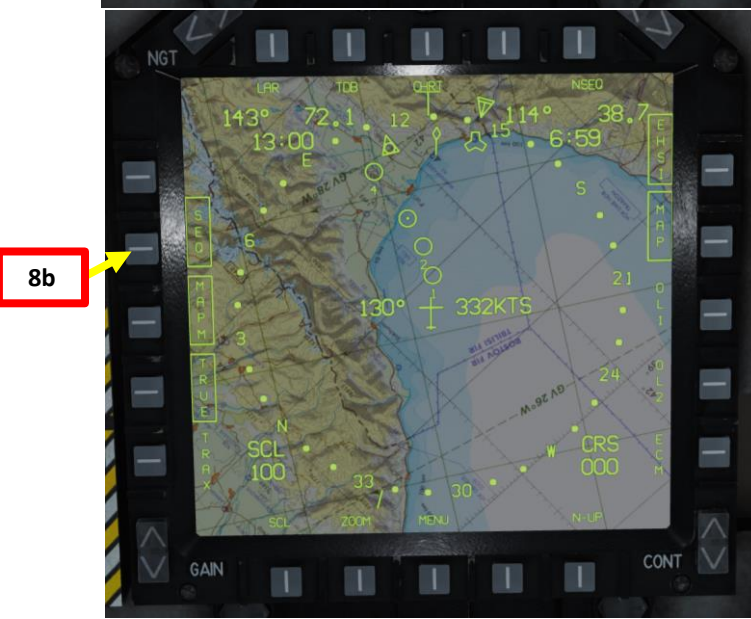
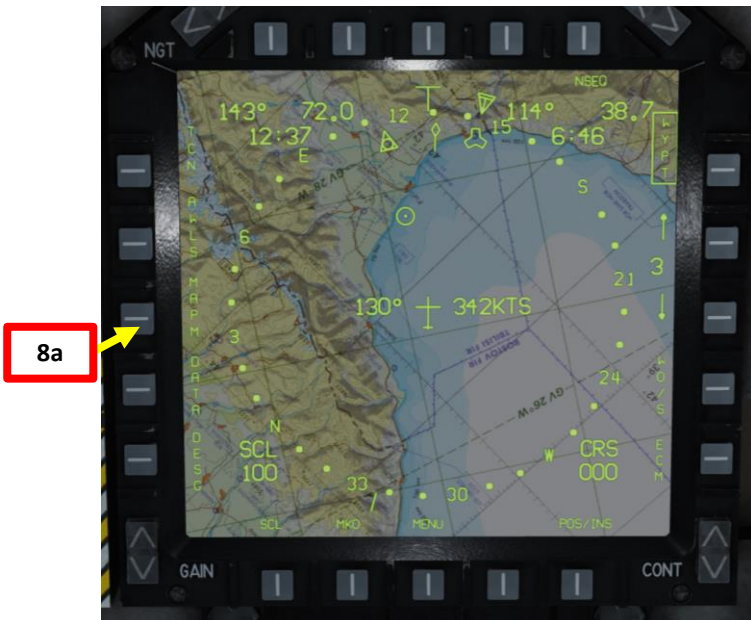

## 4.2 - HOW TO ADD WAYPOINTS

1. We want to create Waypoint 4 after Waypoint 3.
2. Select the EHSD page on either MPCD
3. Click on the OSB next to "DATA" to select the EHSD data sub-menu (will become boxed when selected)
4. Make sure WYPT ODU (Option Display Unit) is selected (":" next to it)
5. On the UFC (Up-Front Controller) scratchpad, press "3", then "4", then "ENT" to enter Waypoint No. 4 after Waypoint No. 3. *Note: Alternatively, you can enter "77", which will add a waypoint after the last waypoint entered.*
6. "\*" 4" should appear on the UFC, meaning a new waypoint numbered "4" has been created.

NOTE: Waypoint 4 has been created but has no coordinates yet.



## 4.3 - HOW TO EDIT WAYPOINTS

1. We will want to edit Waypoint 4, which has been created but does not have any coordinates associated with it yet.
2. Select the EHSD page on either MPCD
3. Click on the OSB next to "DATA" to select the EHSD data sub-menu (will become boxed when selected)
4. Make sure WYPT ODU (Option Display Unit) is selected (":" next to it)
5. On the UFC (Up-Front Controller), press "4", then "ENT" to select Waypoint 4 to edit it.

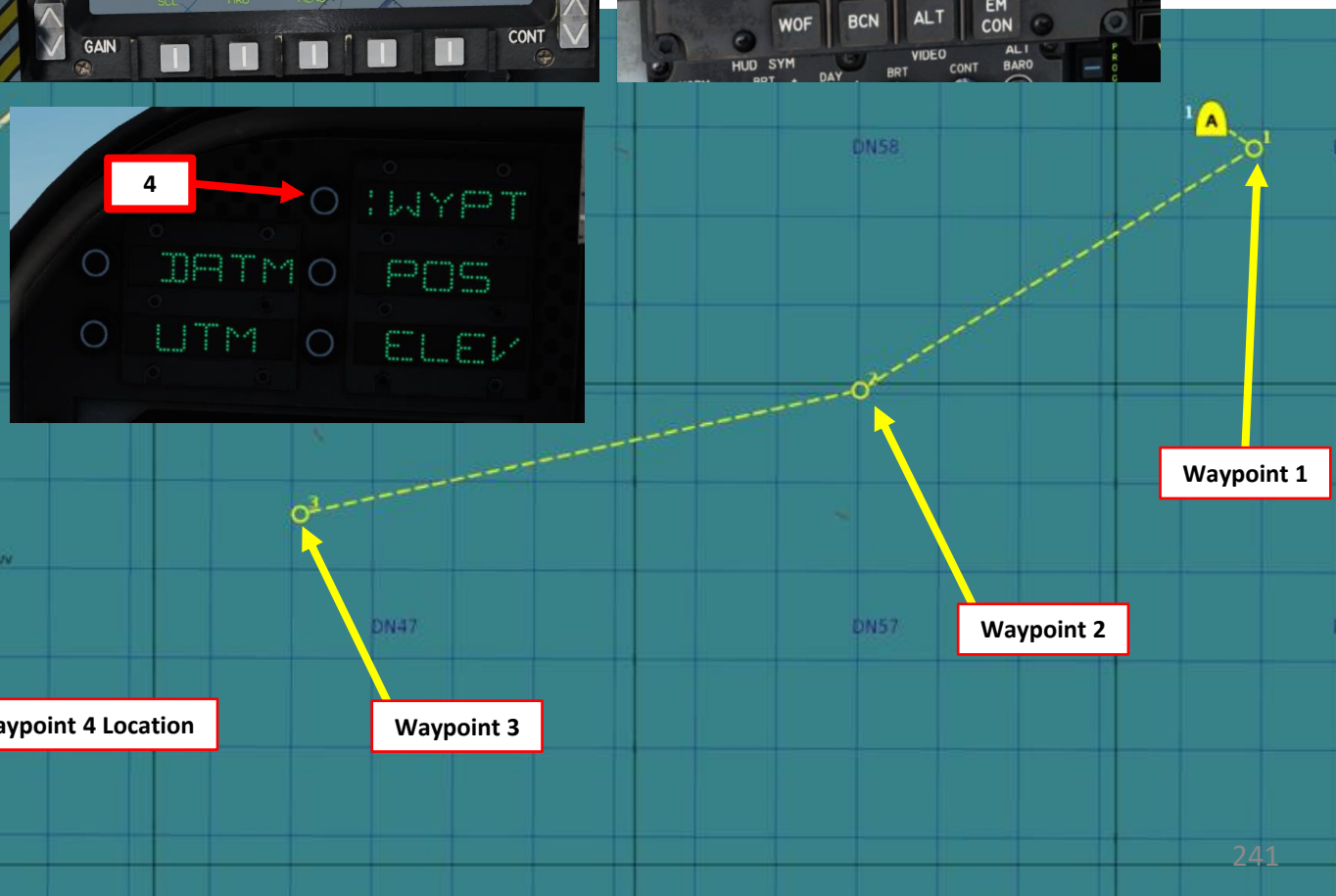
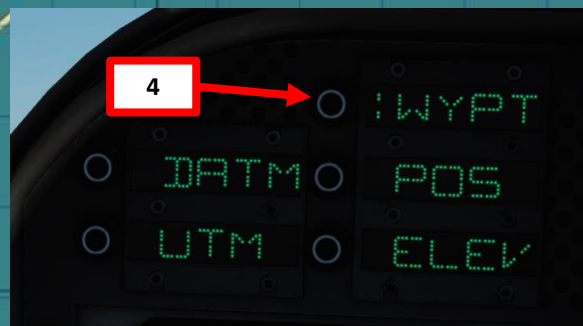
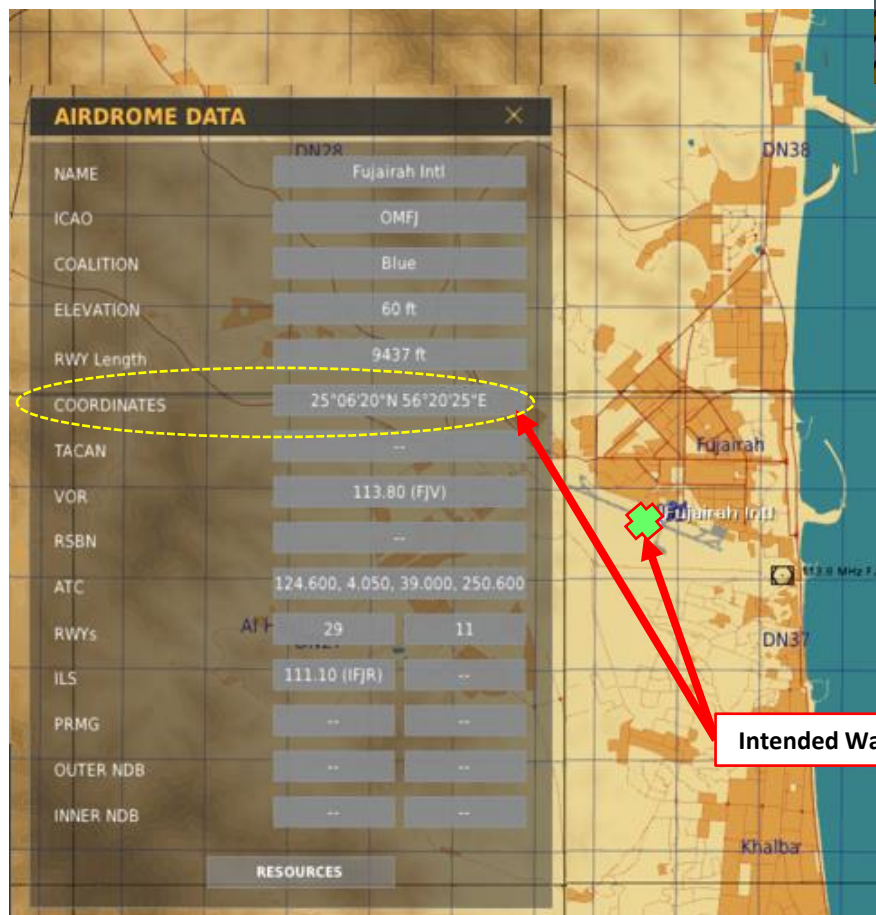
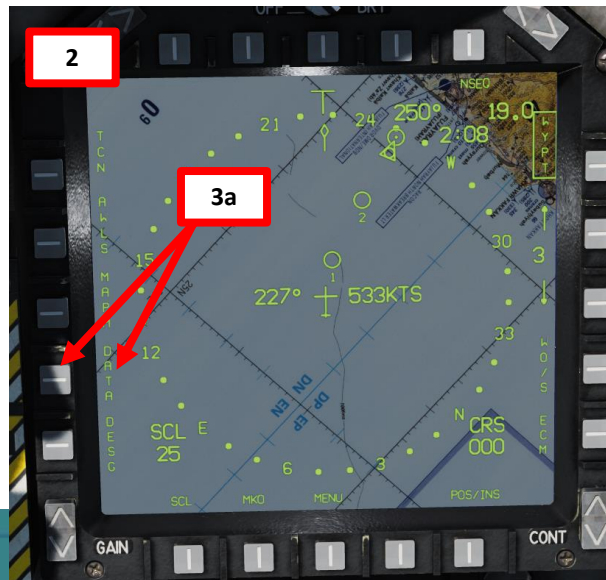

### 4.3 - HOW TO EDIT WAYPOINTS

6. We will add for Waypoint 4 the coordinates of the Fujairah International Airport, which are in (deg, minutes, sec):  
**25°06'20" North 56°20'25" East**
7. Press the POS (Position) ODU (Option Display Unit) to select the coordinate Latitude (":" will appear next to it when selected).
8. On the UFC, press « 2 » (N) to select North coordinates, type « **250620** », then « ENT » to enter them.
9. Press on the POS ODU again to select the coordinate Longitude.
10. On the UFC, press « 6 » (E) to select East coordinates, type « **0562025** », then « ENT » to enter them. Don't forget to add the 0 at the beginning.
11. And that's it! You have edited Waypoint 4's coordinates. If you click on the OSB next to DATA to de-selected it (not boxed), you can see that Waypoint 4 is now visible in the sequence if the SEQ option is enabled.

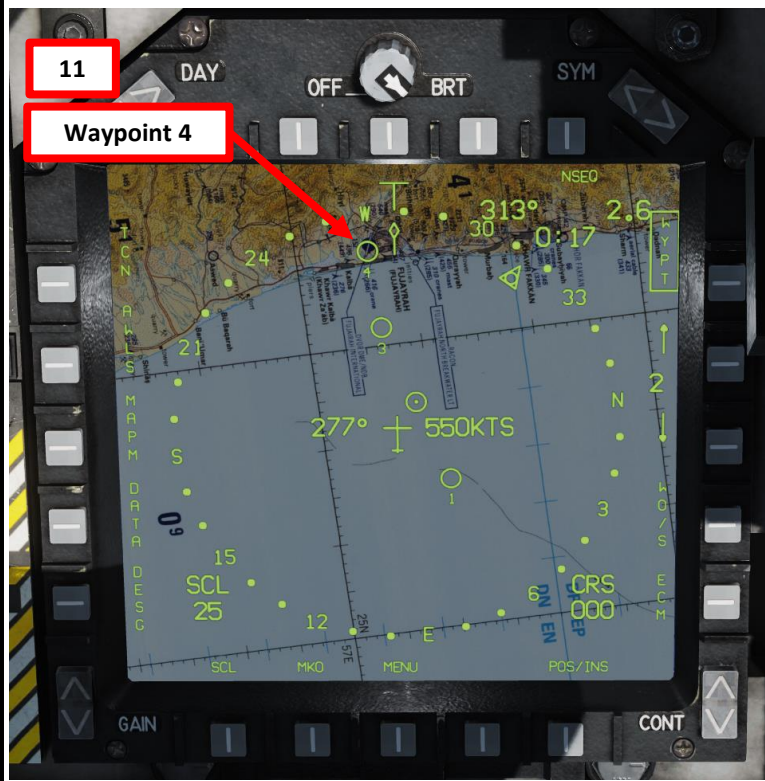

AIRDROME DATA	
NAME	Fujairah Intl
ICAO	OMFJ
COALITION	Blue
ELEVAT	60 ft
RWY Length	9437 ft
COORDINATES	25°06'20"N 56°20'25"E

4.3 - HOW TO EDIT WAYPOINTS

Coordinate format you input in the UFC is Degree, Minute, Seconds.  
 Coordinate format displayed on the DATA page is Degree, Minute, Decimal.  
**INPUT 25 deg 06 minutes 20 seconds = OUTPUT 25 deg 06.333 minutes**

AIRDROME DATA	
NAME	Fujairah Intl
ICAO	OMFJ
COALITION	Blue
ELEVATION	60 ft
RWY Length	9437 ft
COORDINATES	25°06'20"N 56°20'25"E

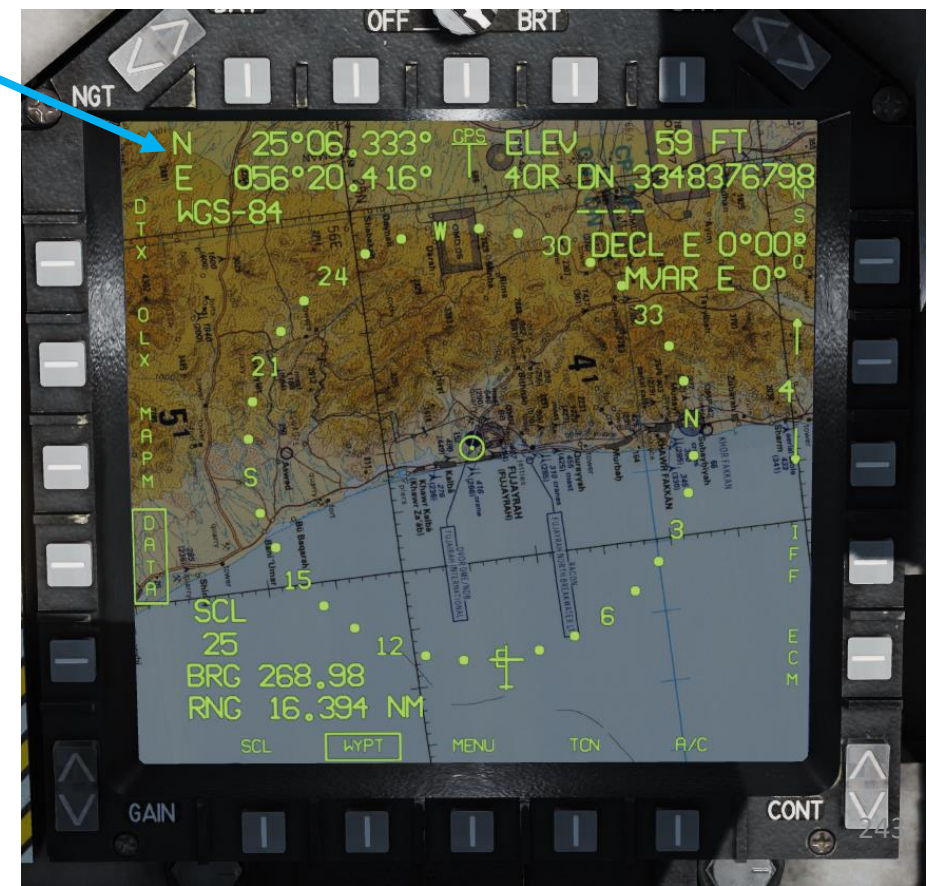
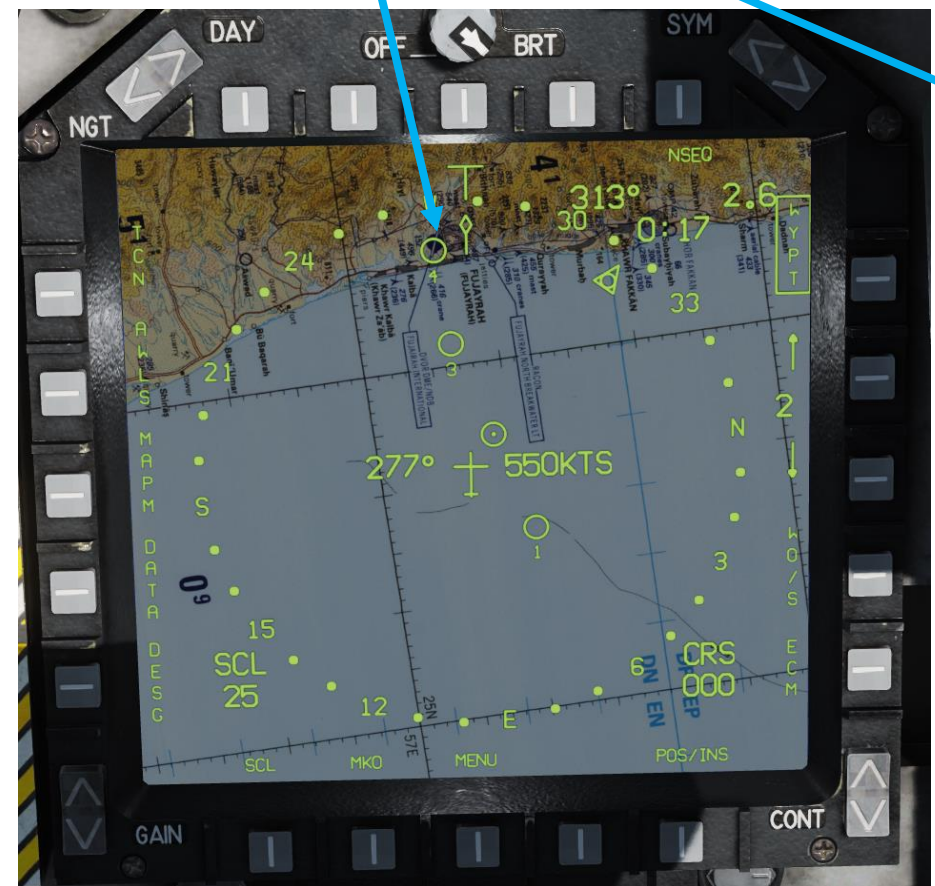

## 4.4 - HOW TO EDIT WAYPOINT WITH MOVING MAP & TDC

What if you already have a waypoint with coordinates and want to move it quickly to somewhere else? There's a neat trick that allows you to do it quite simply with the TDC.

1. Select the EHSD page on either MPCD
2. Make sure the Moving Map is activated (see the AMAP: Moving Map Tutorial).
3. Click on the OSB next to "DATA" to select the EHSD data sub-menu (will become boxed when selected)
4. Press the WYPT ODU (Option Display Unit) is selected (":" next to it)
5. On the UFC (Up-Front Controller), press "4", then "ENT" to select Waypoint 4 to edit.
6. Press the POS (Position) ODU (Option Display Unit)

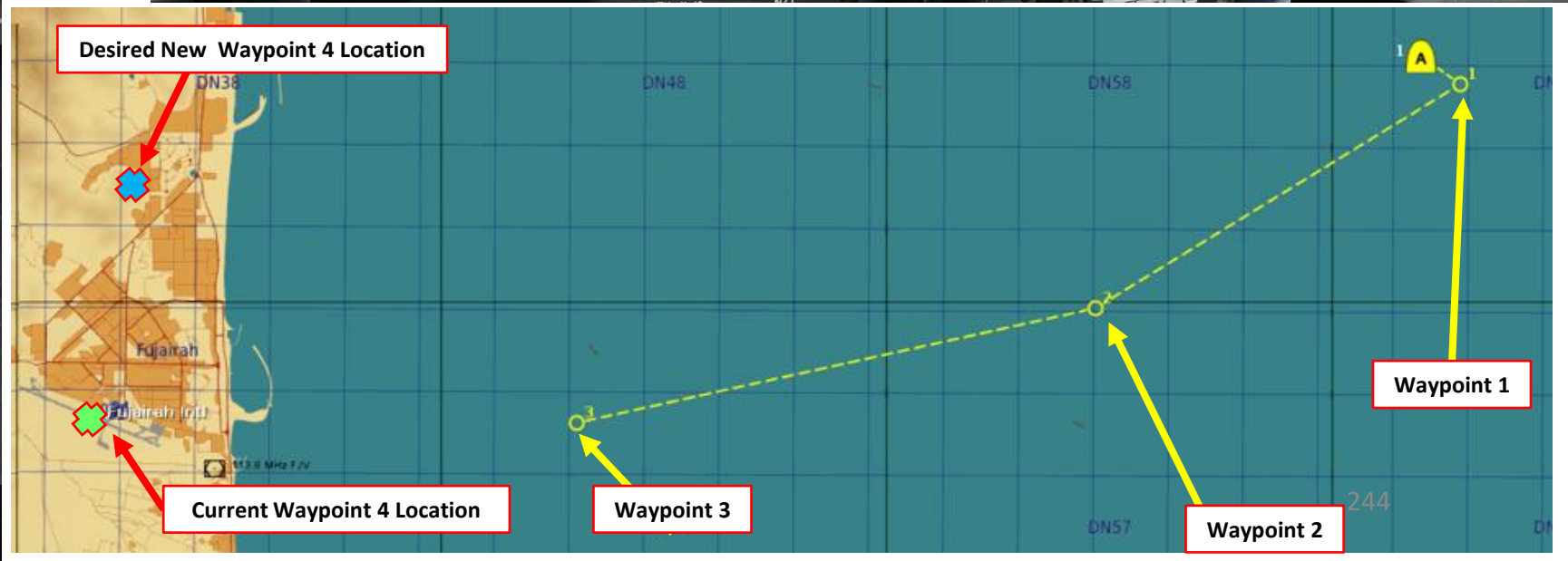
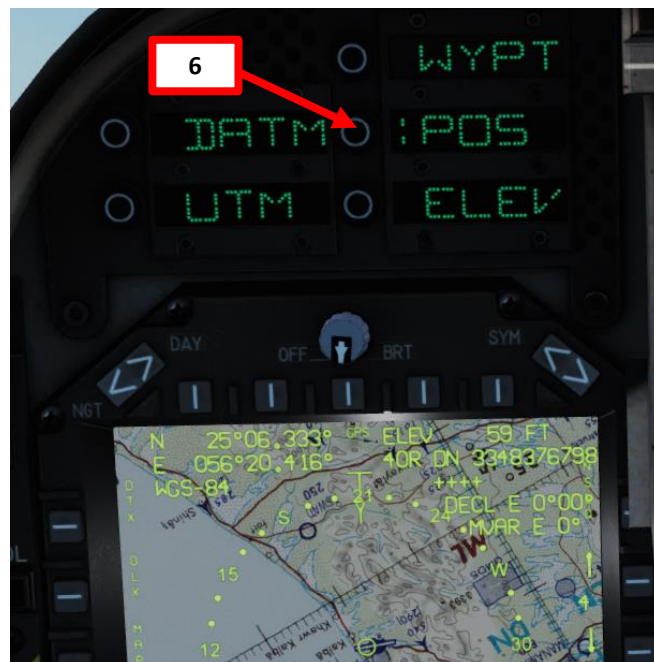

## 4.4 - HOW TO EDIT WAYPOINT WITH MOVING MAP & TDC

- Press the Sensor Select Switch – FWD (INS) to slave the TDC (Target Designation Caret) to the Inertial Navigation System.
- Press on the OSB next to SCL (scale) to choose desired scale. This can be useful to zoom out if you need to move the waypoint a long distance since the TDC is automatically scaled with the Moving Map scale.
- Use the TDC controls to move the waypoint on the moving map
- Once you are satisfied with its location, click on the OSB next to DATA to de-select the data sub-menu.

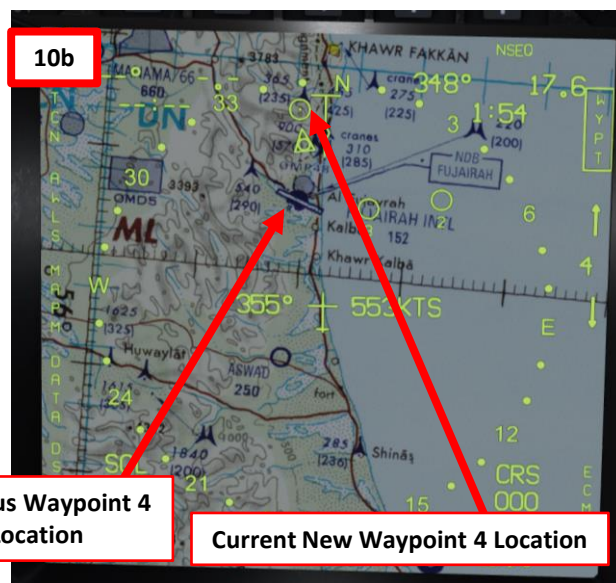

**Sensor Select Switch**  
 AFT = DMT: LST/TV  
 FWD = INS: IRMV/EOMV  
 LEFT = MAP Center/Decenter  
 RIGHT = FLIR/HUD-BH/WH  
 DOWN (PUSHED) = HUD Scene Reject/TPOD

7

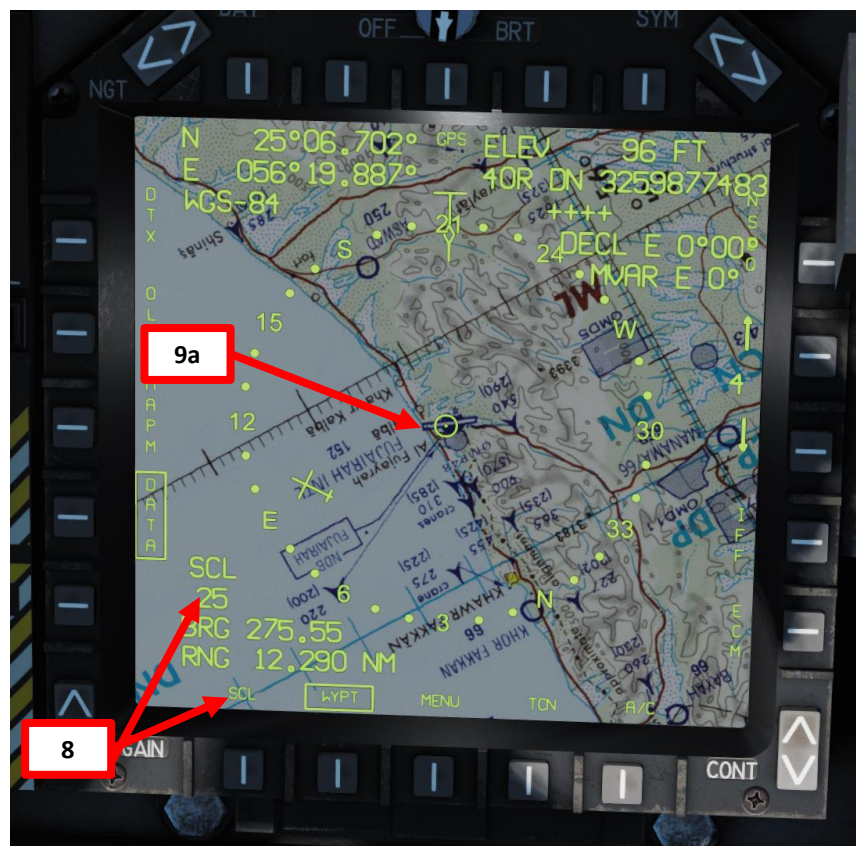

**TDC (Target Designation Caret) Control Switch**  
 LEFT/RIGHT/FORWARD/AFT/DOWN (ACTION)



## 4.5 – WAYPOINT OFFSET

1. The most common use for a Waypoint Offset is a Bullseye Call. If the Bullseye is set on a Waypoint (in our case Waypoint 2) and we receive a Bullseye call for a target with a bearing and range from the Bullseye, we can create a “Waypoint Offset” and navigate to it just like any other waypoint.
2. As an example, a threat is at “Bullseye 200 for 15 miles”. Since our Waypoint 2 is set to the Bullseye location, we can create a waypoint offset at a bearing of 200 and at a distance of 15 nm from WP2.
3. Make sure the HUD Master Mode is set to NAV to be able to track your waypoint directly from your HUD.
4. Select the EHSD page on either MPCD
5. Select Waypoint 2 (set on Bullseye) with OSBs or the Waypoint Increment button.
6. Click on the OSB next to “DATA” to select the EHSD data sub-menu (will become boxed when selected)
7. Press the ODU (Option Display Unit) next to WYPT to toggle WYPT to WO/S.

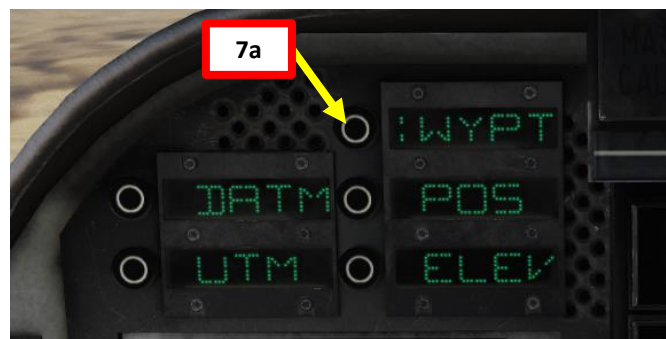
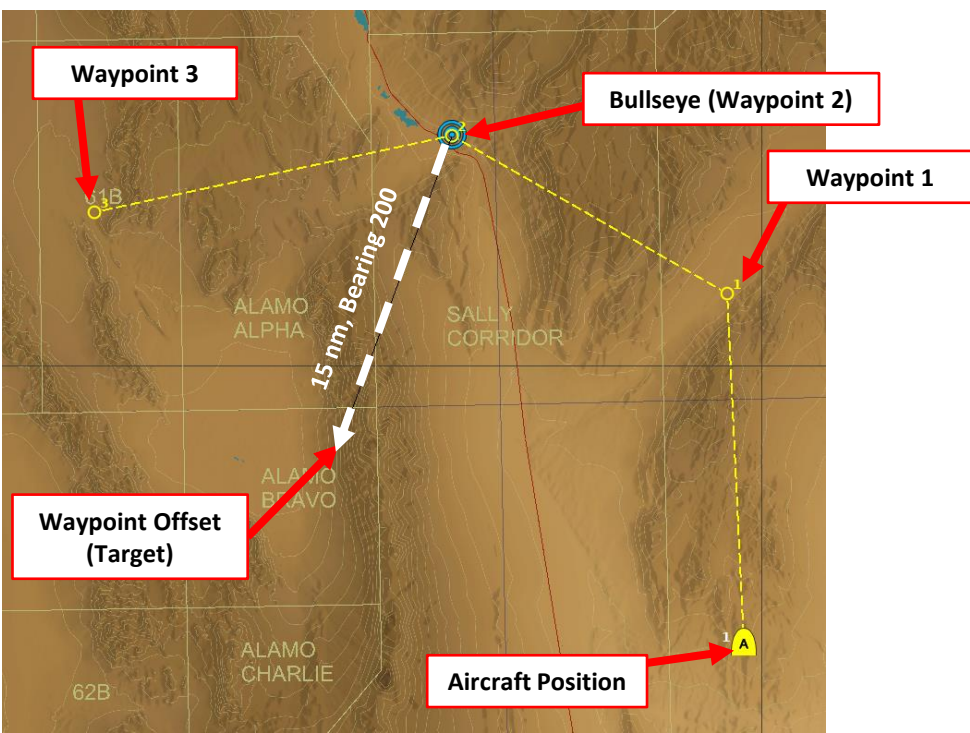
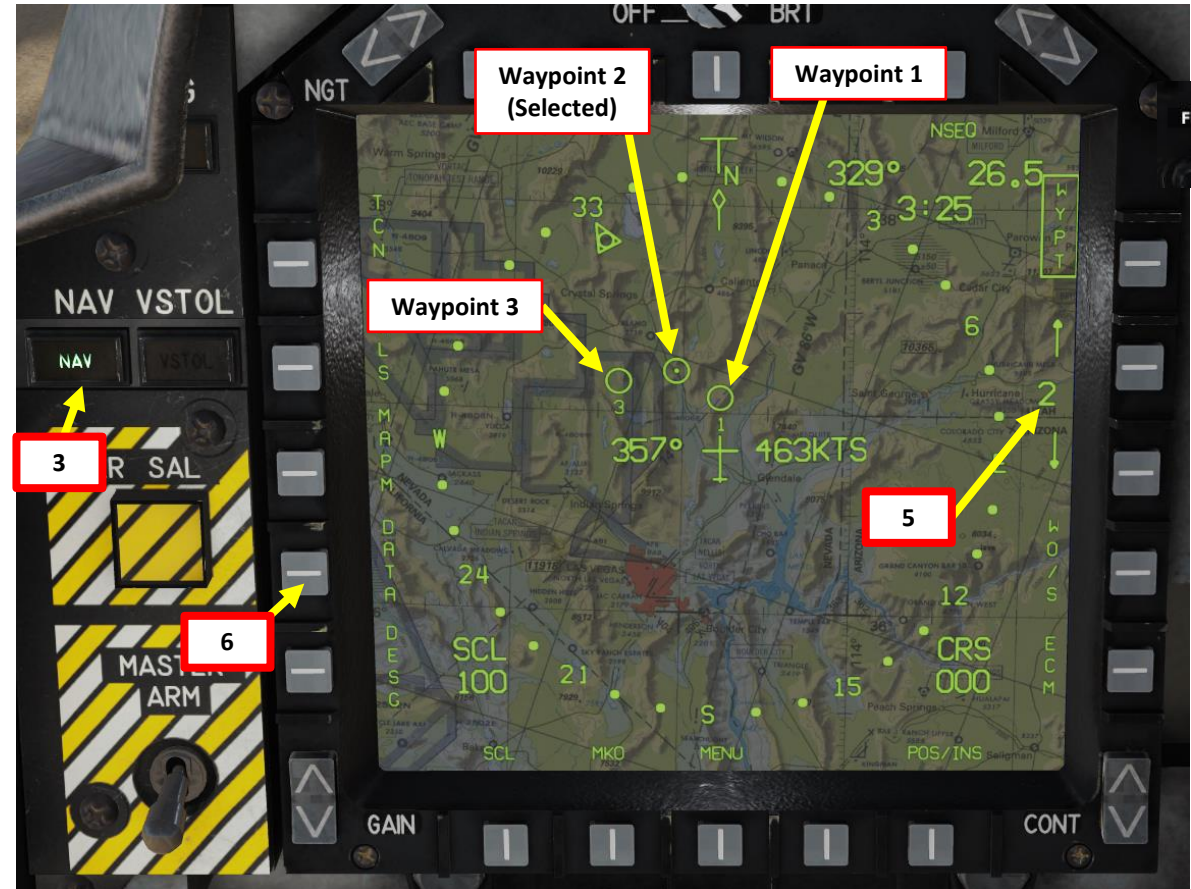

# 4.5 – WAYPOINT OFFSET

8. Enter the Waypoint Offset Bearing of 200 by selecting the “BRG” (Bearing) ODU (“:” appears when selected), then entering “200” on the UFC, and pressing “ENT”.
9. Enter the Waypoint Offset Range of 15 nm by selecting the “RNG” (Range) ODU (“:” appears when selected), then entering “15” on the UFC, and pressing “ENT”.
10. Exit the EHSD DATA sub-menu by pressing the OSB next to “DATA”.
11. Press the OSB next to “WO/S” (Waypoint Offset) to select the Waypoint 2 Offset (boxed when selected).
12. The Waypoint 2 Offset will appear on the EHSD and the HUD as well.
13. To track Waypoint 2 without the Waypoint Offset, press the “WO/S” OSB again to unselect it.

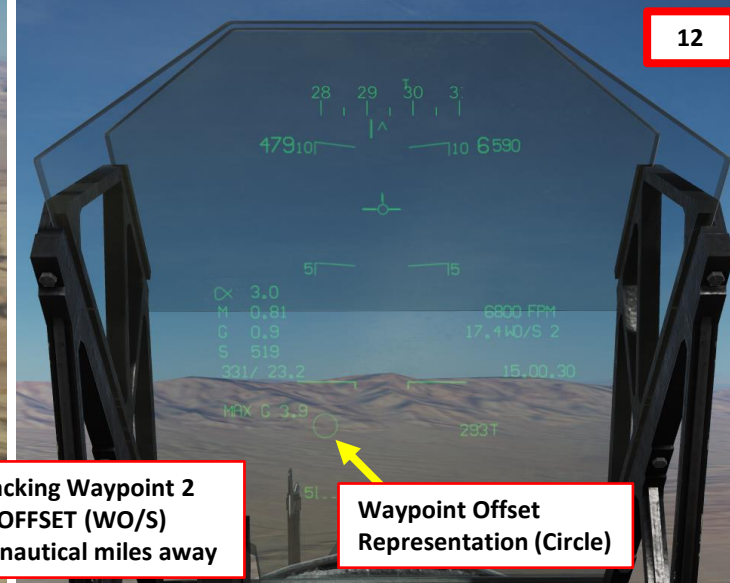
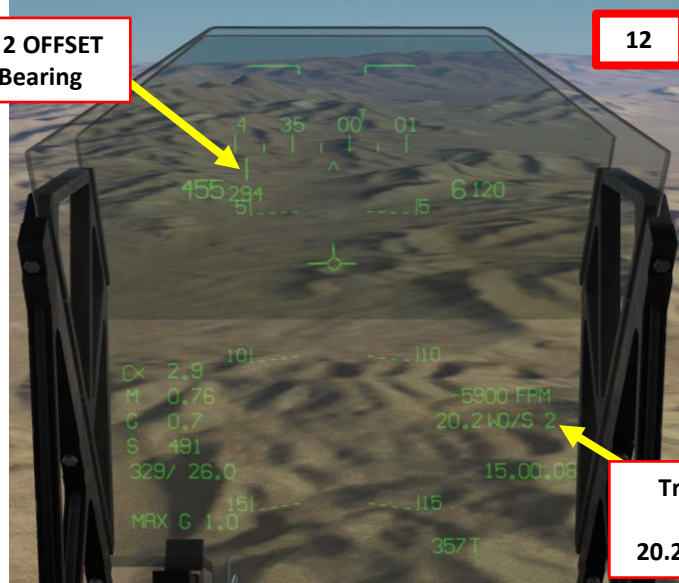

Tracking Waypoint 2 OFFSET (WO/S) 20.2 nautical miles away

Waypoint Offset Representation (Circle)

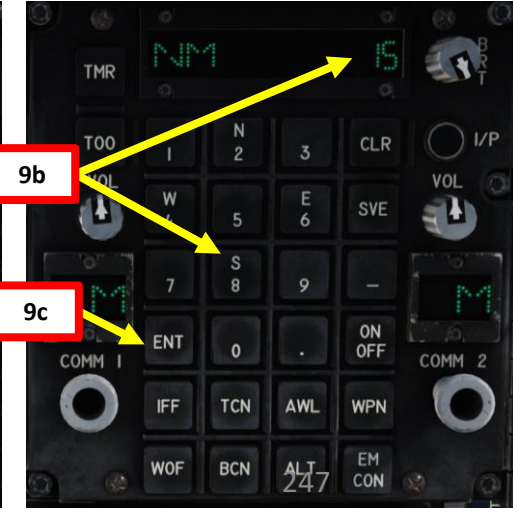
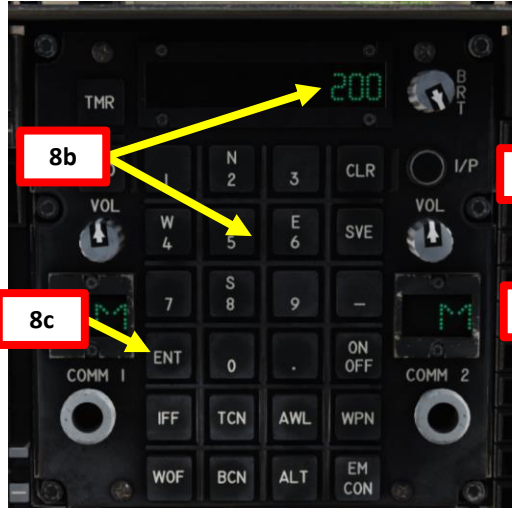
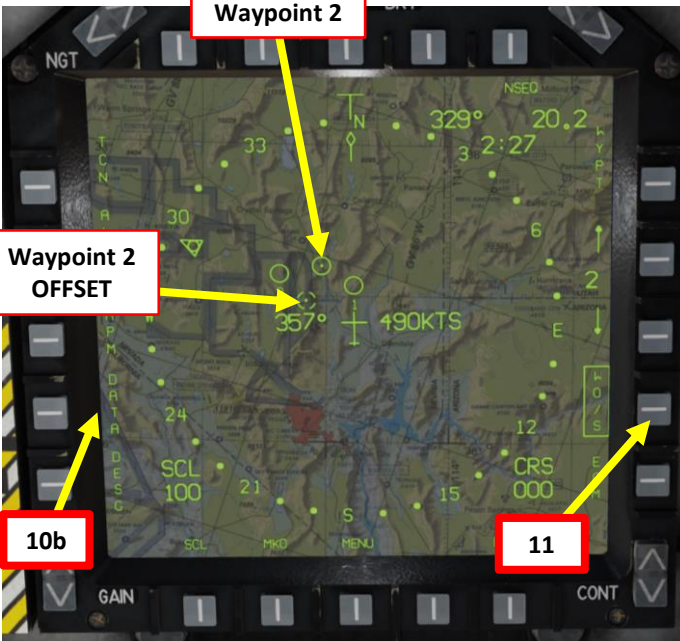
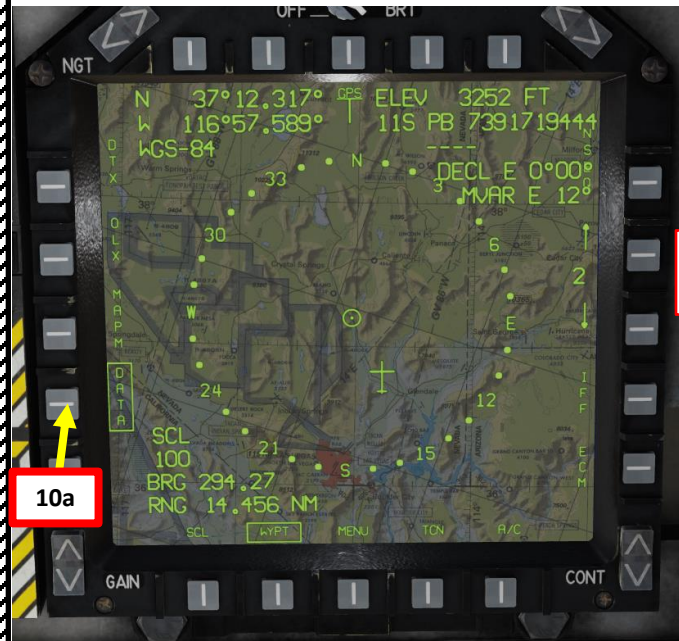

## 5.1 - MARKPOINT NAVIGATION

1. Select the EHSD page on either MPCD
2. Press the OSB next to WYPT to set tracking mode to WAYPOINT.
3. To select a markpoint, press the OSB (Option Select Button) to increment or decrement the waypoint number until you reach the desired Markpoint (M1, M2, etc). Alternatively, you can use the WP Increment button on the stick.
4. Make sure the HUD Master Mode is set to NAV to be able to track your waypoint directly from your HUD.
5. Consult EHSD and HUD to find selected Markpoint

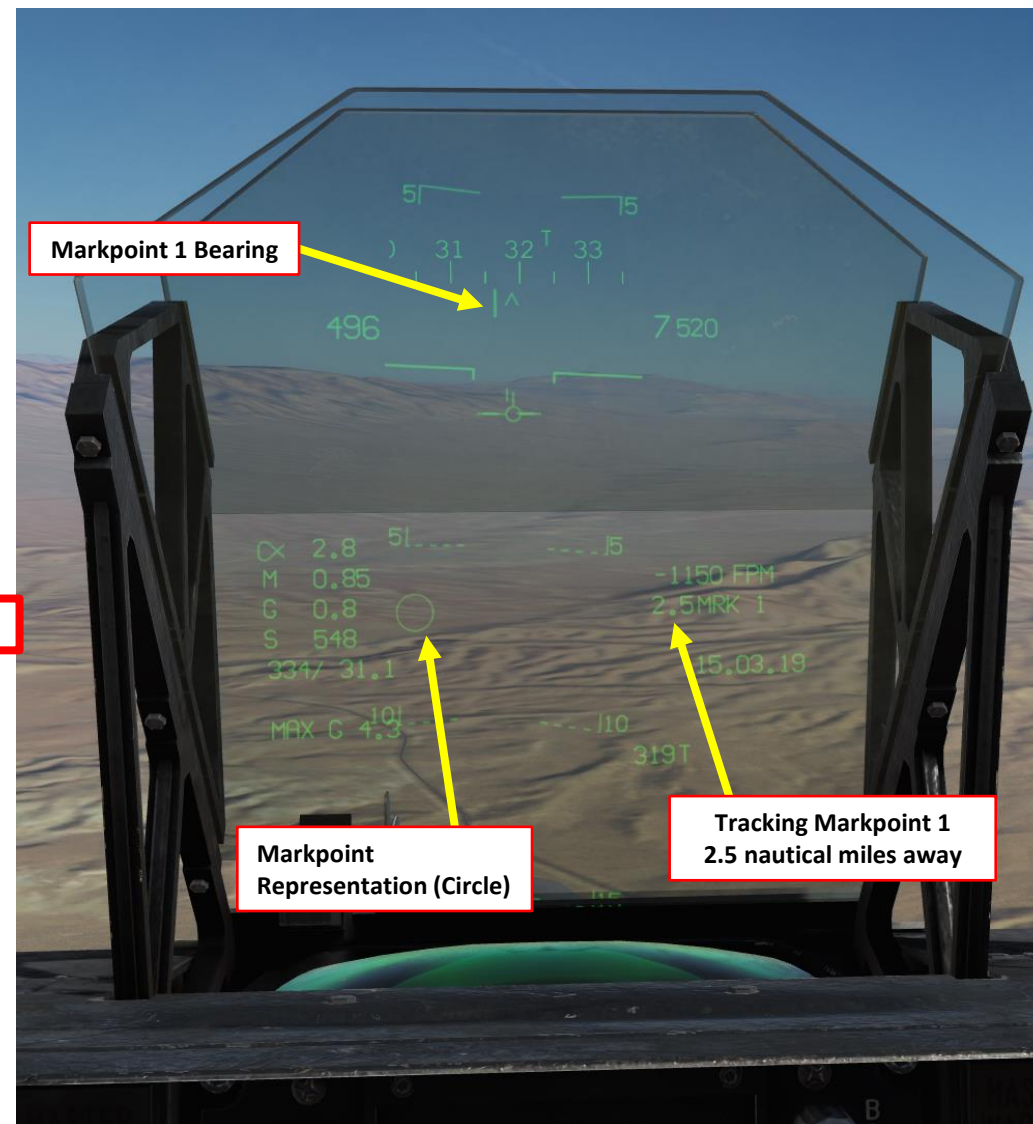
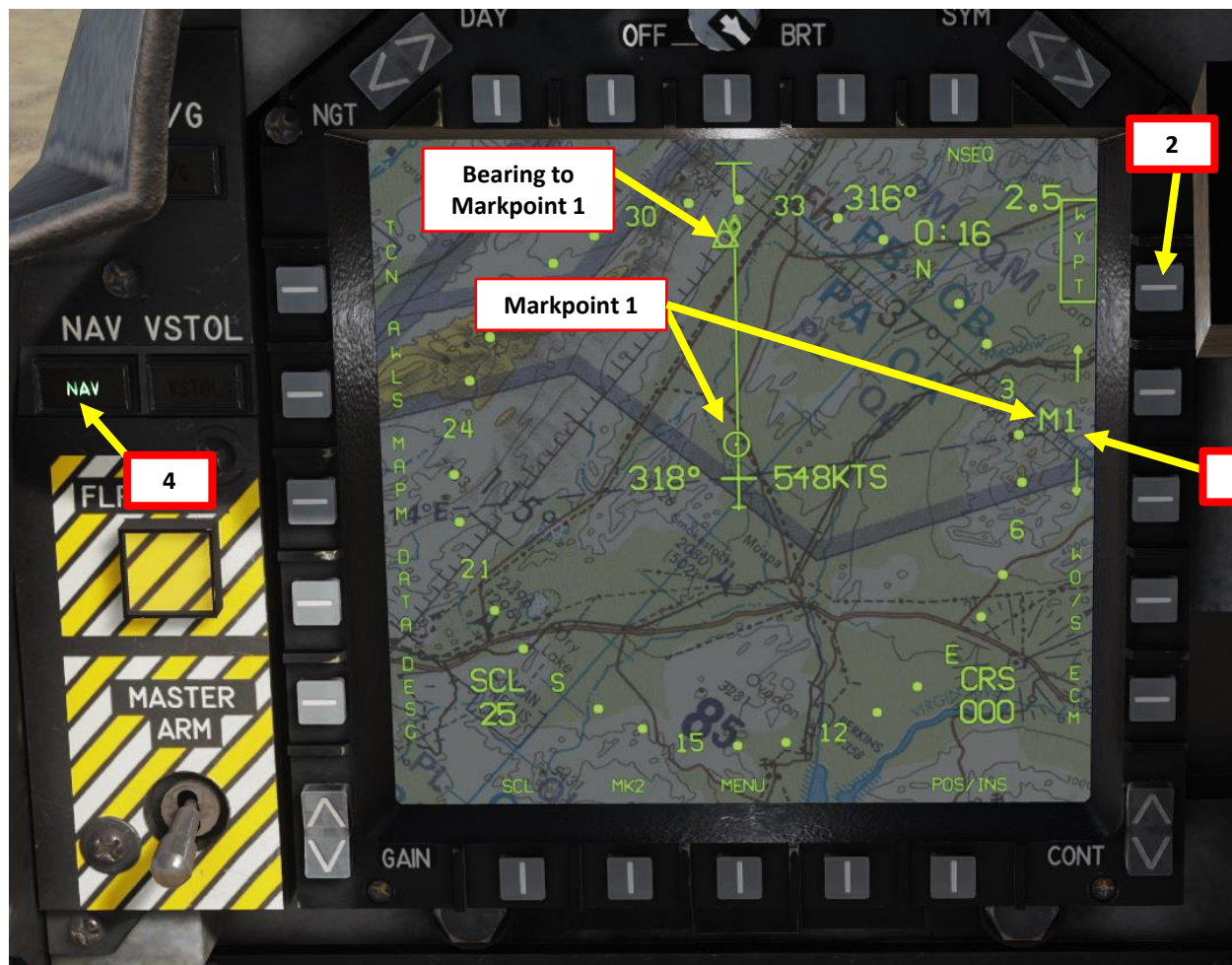

## 5.2 - HOW TO ADD MARKPOINTS

1. Select the EHSD page on either MPCD
2. To create a markpoint, simply press the OSB next to "MK".
3. A markpoint will be created at the aircraft's location at the time the Markpoint OSB was pressed.



### 5.3 - USING MARKPOINTS

You can use markpoints just like regular waypoints. This means that you can use course lines, track them, and modify their position as desired using the UFC and ODUs.



## 6.1 – TARGETPOINT CREATION

1. Make sure either the DMT (Dual Mode Tracker) is ON or the Targeting Pod is equipped and warmed up.
2. Make sure HUD Master Mode is set to either NAV or A/G.
3. To create a waypoint, press the TDC switch DOWN. This will create a Targetpoint where the velocity vector is pointing on your HUD (or where the Targeting Pod is looking if T-POD page is selected).

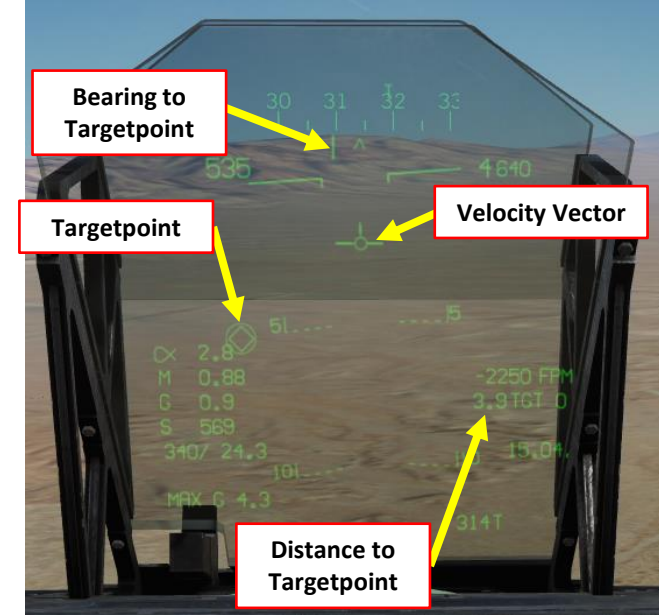

INS Mode Selected, TDC Slewing is not possible in this mode

TDC (Target Designation Caret) Control Switch LEFT/RIGHT/FORWARD/AFT/DOWN (ACTION)

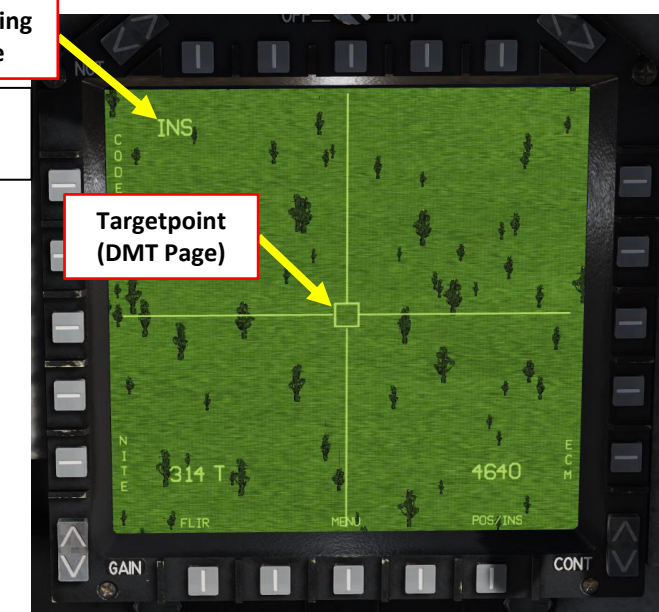

# 6.1 – TARGETPOINT CREATION

- Take note that a Targetpoint is created and memorized every time you press the Air-to-Ground Bomb Pickle Button and release a bomb in CCIP. This functionality is quite useful if you need to perform subsequent passes on a single target.
- You can slew the Targetpoint by pressing the Sensor Select Switch AFT (selects DMT TV mode) and then using the TDC Left/Right/Forward/Aft switch to move the cursor, then pressing the TDC DOWN switch to designate the target. Alternatively, you can also do it by using the targeting pod.

### Air-to-Ground Bomb Pickle Button

Releases bombs or launches rockets or Maverick air-to-ground missiles

4



### TDC (Target Designation Caret) Control Switch

LEFT/RIGHT/FORWARD/AFT/DOWN (ACTION)

5b

5c



5a

### Sensor Select Switch

AFT = DMT: LST/TV  
 FWD = INS: IRMV/EOMV  
 LEFT = MAP Center/Decenter  
 RIGHT = FLIR/HUD-BH/WH  
 DOWN (PUSHED) = HUD Scene Reject/TPOD

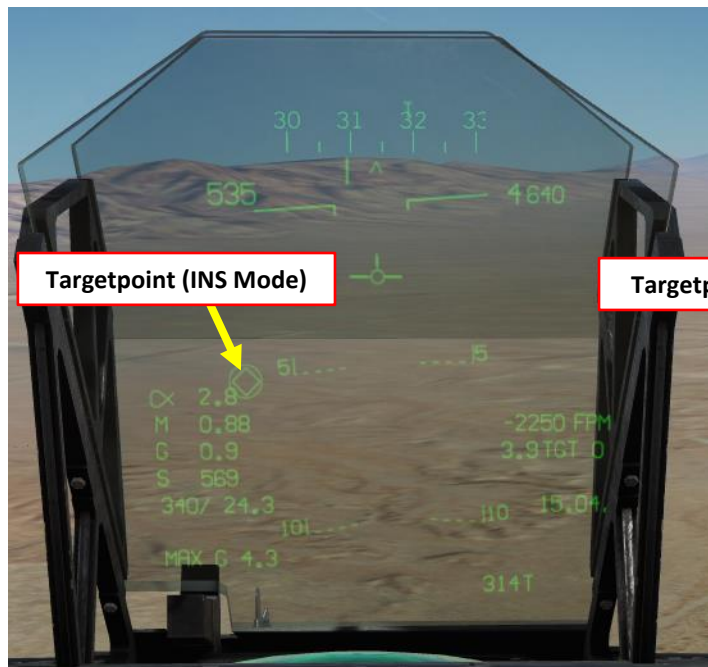

Targetpoint (INS Mode)

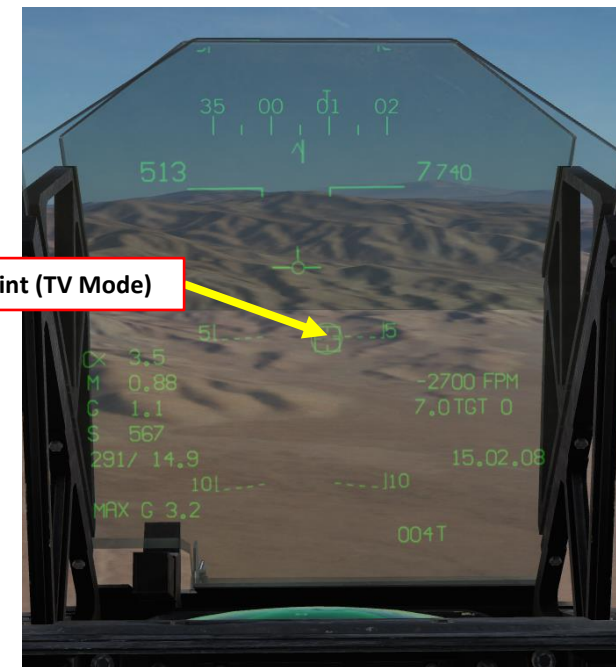

Targetpoint (TV Mode)

INS Mode Selected, TDC Slewing is not possible in this mode

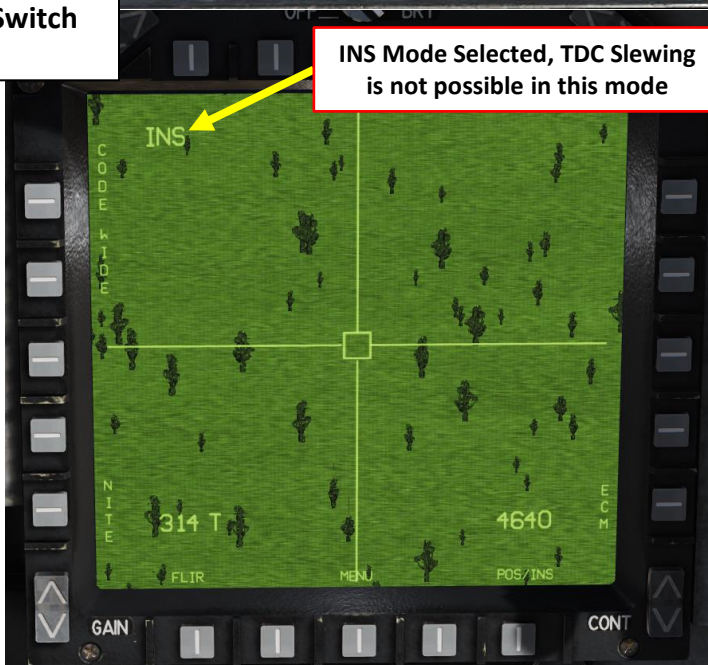

TV Mode Selected, TDC Slewing is possible in this mode

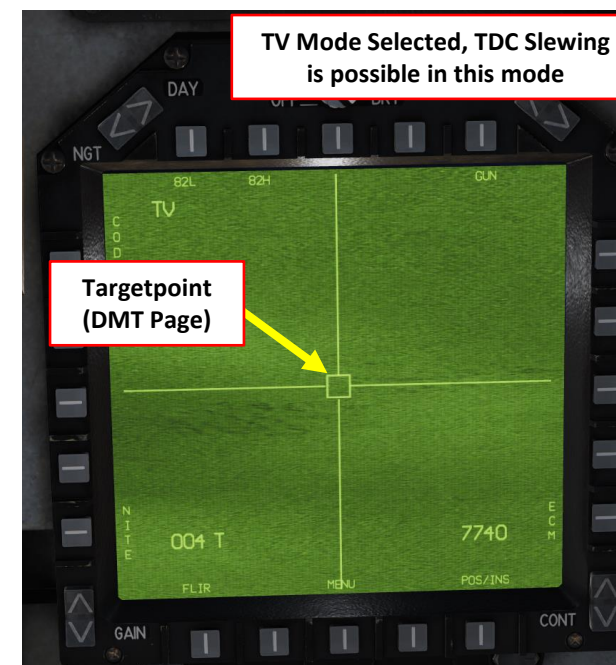

Targetpoint (DMT Page)

## 6.2 - WAYPOINT DESIGNATE

You can designate a waypoint as a Targetpoint by selecting the desired Waypoint, then pressing the OSB next to "DESG". This is useful for large targets that are located on an existing waypoint.

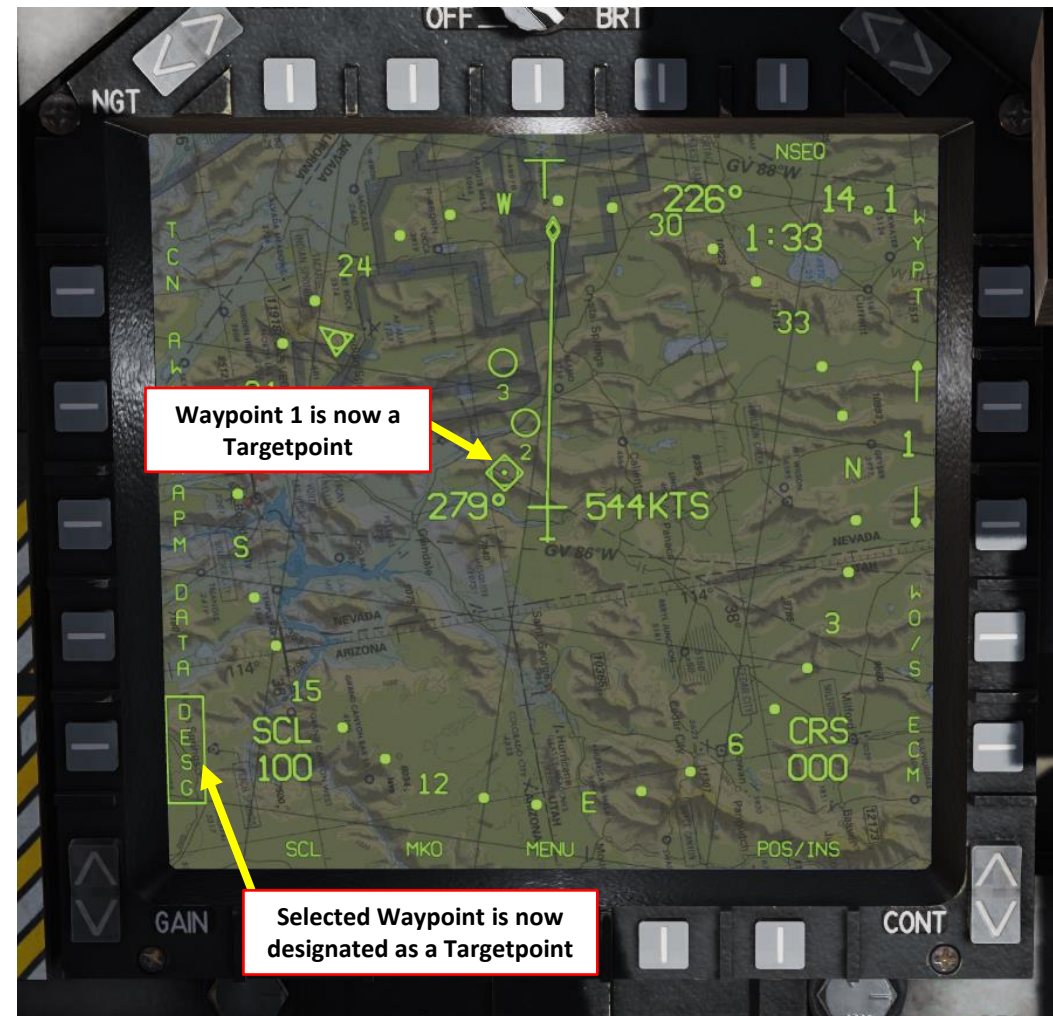
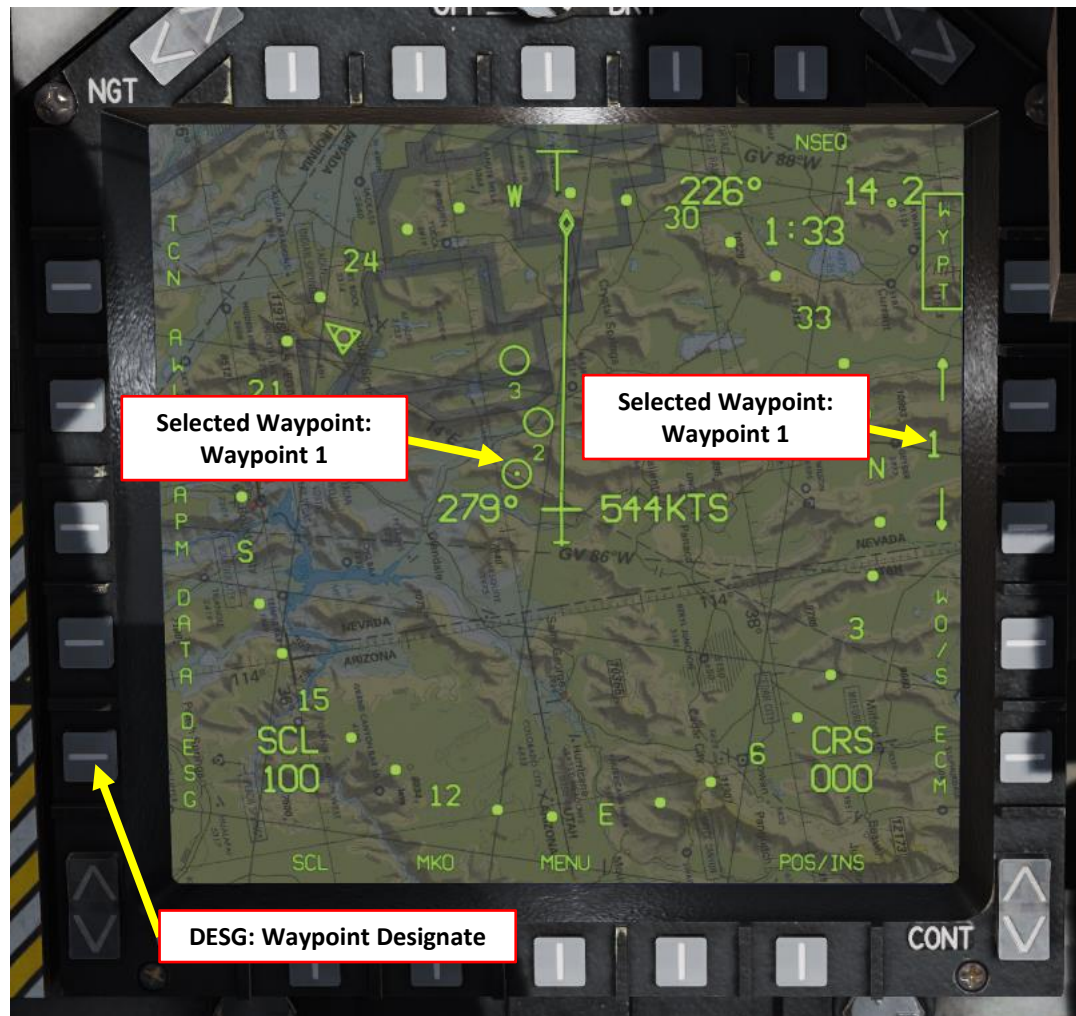

## 6.3 - USING TARGETPOINTS

Targetpoints are used mainly for weapon release. However, using the EHSD DATA sub-menu when a Targetpoint is selected (TO) allows you to read the target point's coordinates and elevation, which you can relay to friendly aircraft with GPS-guided weapons.



# 7 - TACAN NAVIGATION

- Determine the TACAN frequency you want to track by opening the map with F10 and by clicking on the airport you want to track. The frequency of the TACAN beacon for Senaki-Kolkhi is 31X.

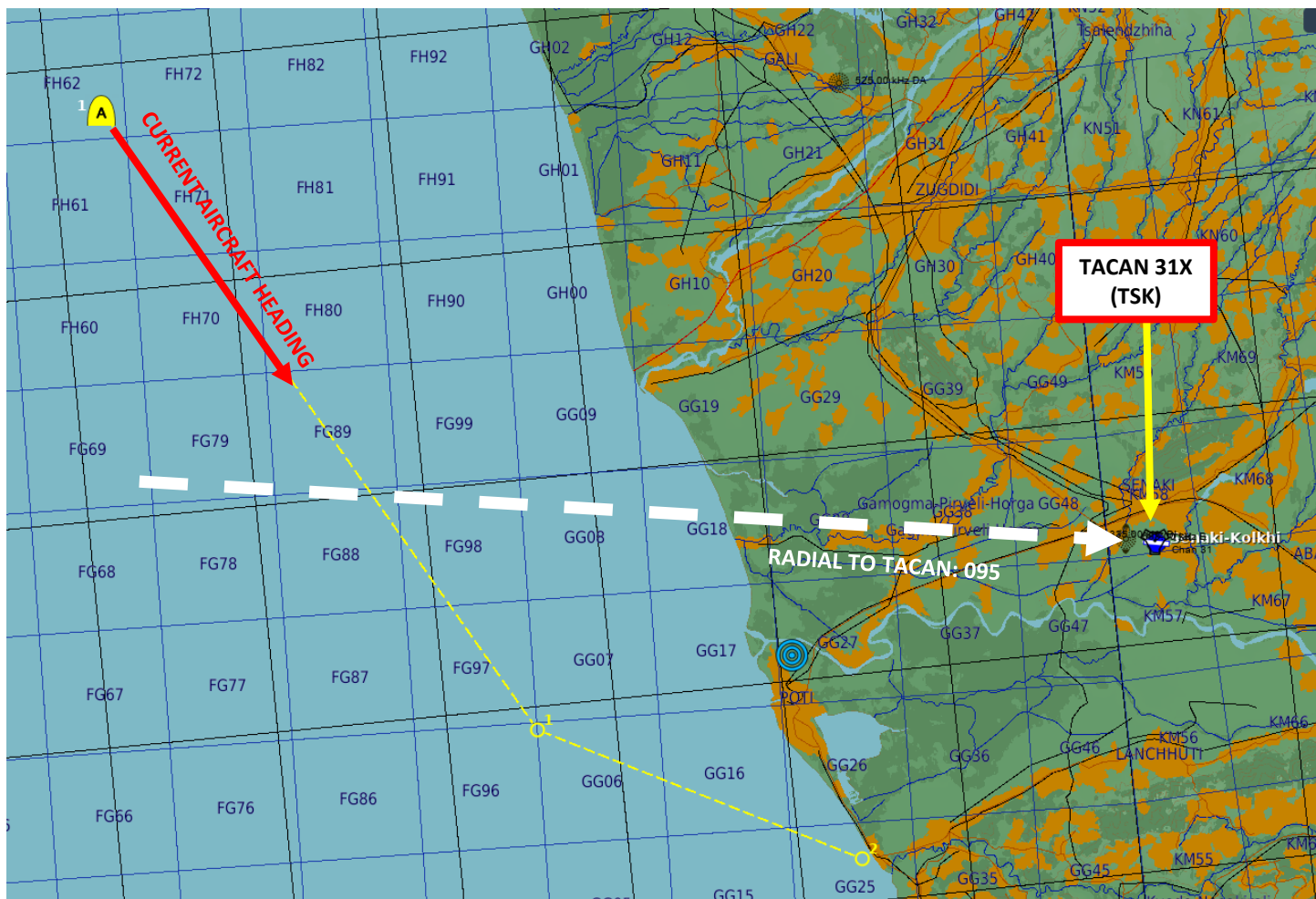

AIRDROME DATA	
NAME	Senaki-Kolkhi
ICAO	UGKS
COALITION	Neutral
ELEVATION	43 ft
RWY Length	7256 ft
COORDINATES	42°14'19"N 42°03'39"E
TACAN	31X (TSK)
VOR	--
RSBN	--
ATC	4.300, 132.000, 40.600, 261.000
RWYs	27      9
ILS	--      108.90 (ITS)
PRMG	--      --
OUTER NDB	--      335.00 (BI)
INNER NDB	--      688.00 (B)
RESOURCES	



# 7 - TACAN NAVIGATION

- Select the EHSD page on either MPCD
- On the UFC (Up-Front Control) Panel, press the TCN button and press the ON/OFF button if the ON indication is extinguished.
- Press the T/R ODU (Option Display Unit) button to set it to Transmit/Receive. The ":" symbol indicates that it is selected.
- Press "31" on the scratchpad and press "ENT" to enter frequency.
- Press the X/Y ODU to toggle the right letter of the TACAN frequency (31X in our case).
- If you are tracking an aerial TACAN beacon (i.e. on a tanker), press the A/A ODU button to select air-to-air mode. The ":" symbol indicates that the mode is selected. Otherwise, make sure A/A is not selected (no ":" symbol).
- Press the OSB next to TACAN to select tracking mode to TACAN. Once selected, TCN should be boxed.
- Adjust desired radial to TACAN by using the CRS (Course) knob. We will use 095. A course line will appear on the TACAN beacon.
- Set the HUD Master Mode switch to NAV.
- Once frequency is set and options are set, you can track the TACAN beacon via the EHSD (Electronic Horizontal Situation Display) page and the HUD (Heads-Up Display).

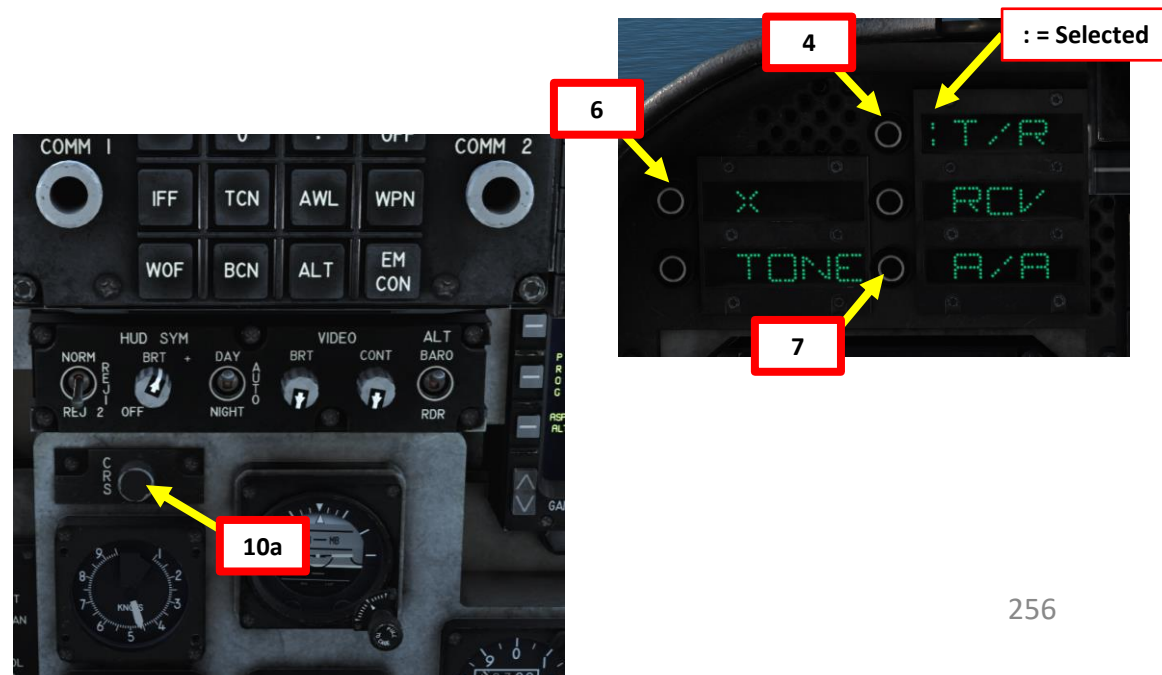
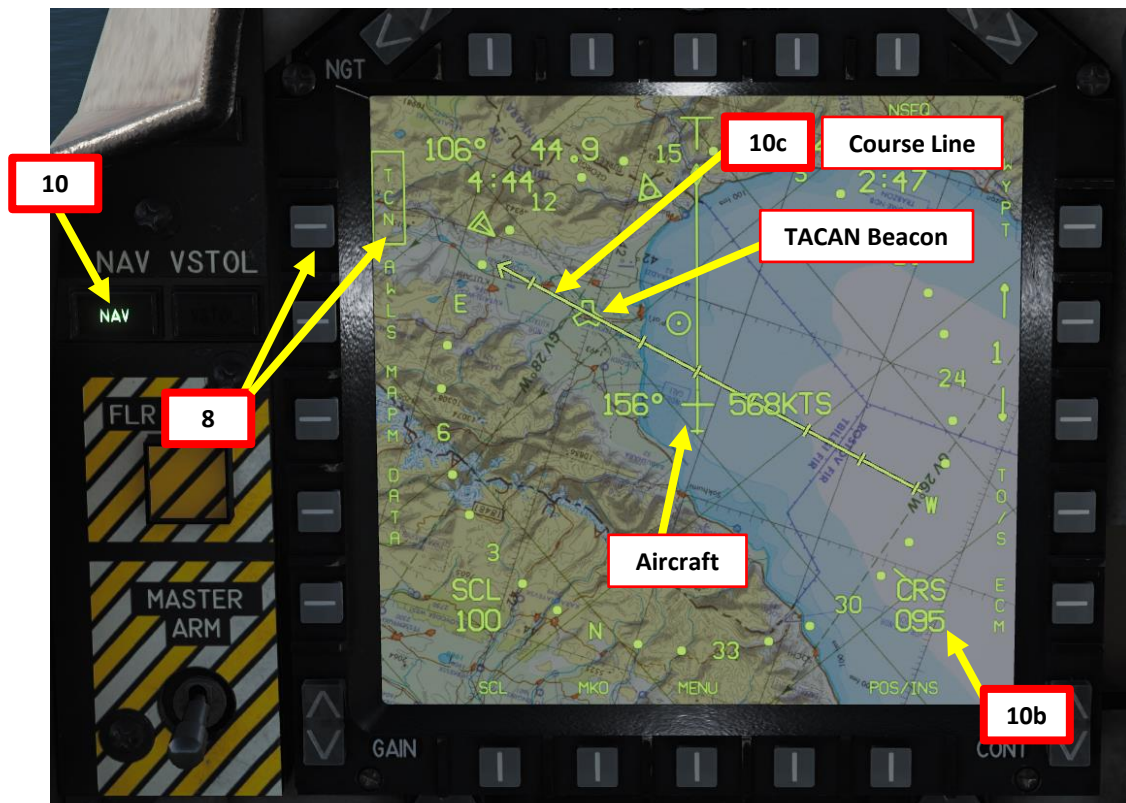
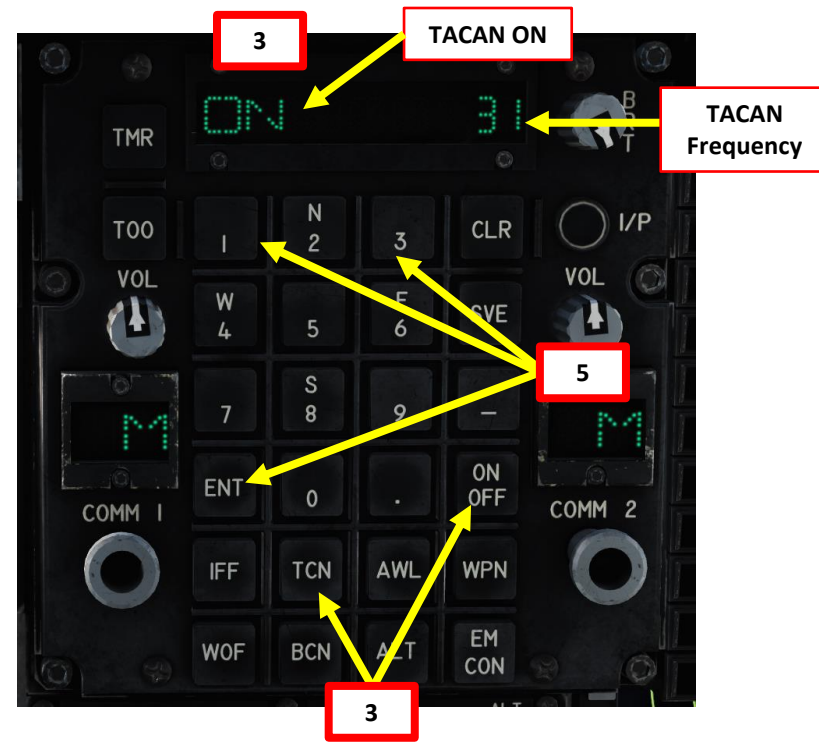

7 - TACAN NAVIGATION

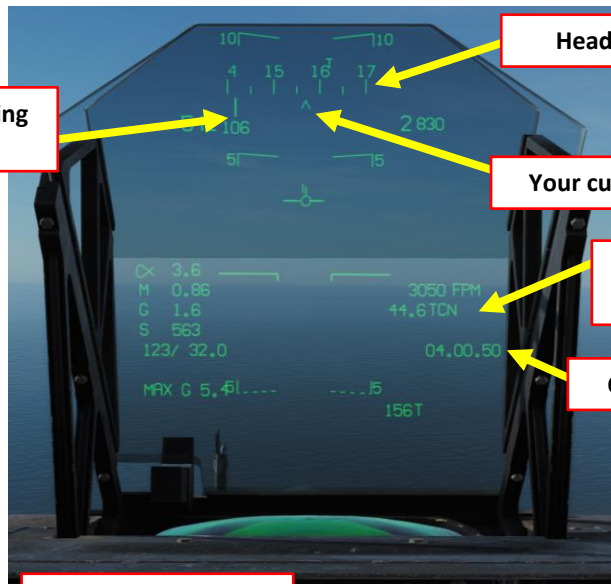

Selected TACAN Bearing (to your left)

Heading Tape

Your current heading

Distance to TACAN (nm)

Clock

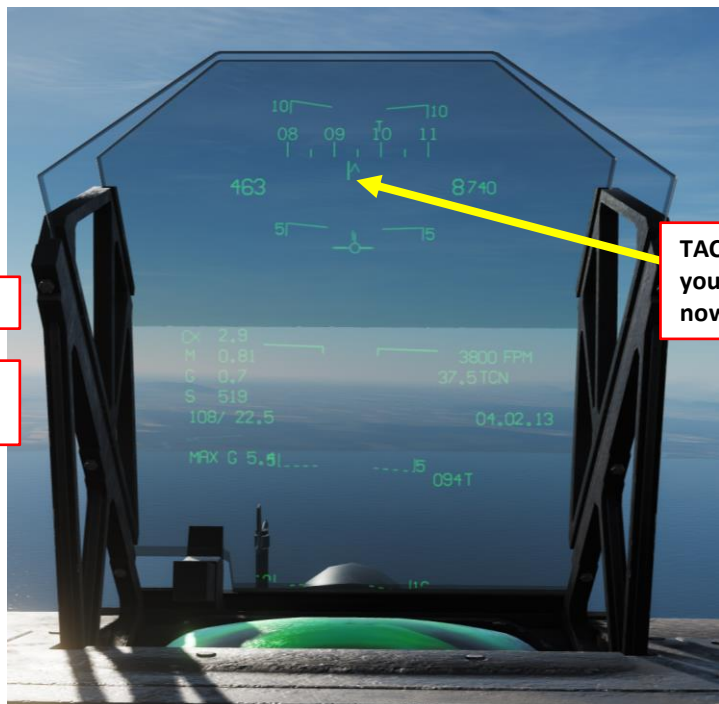

TACAN Bearing (vertical bar) and your current heading (triangle) are now aligned. You are on course!

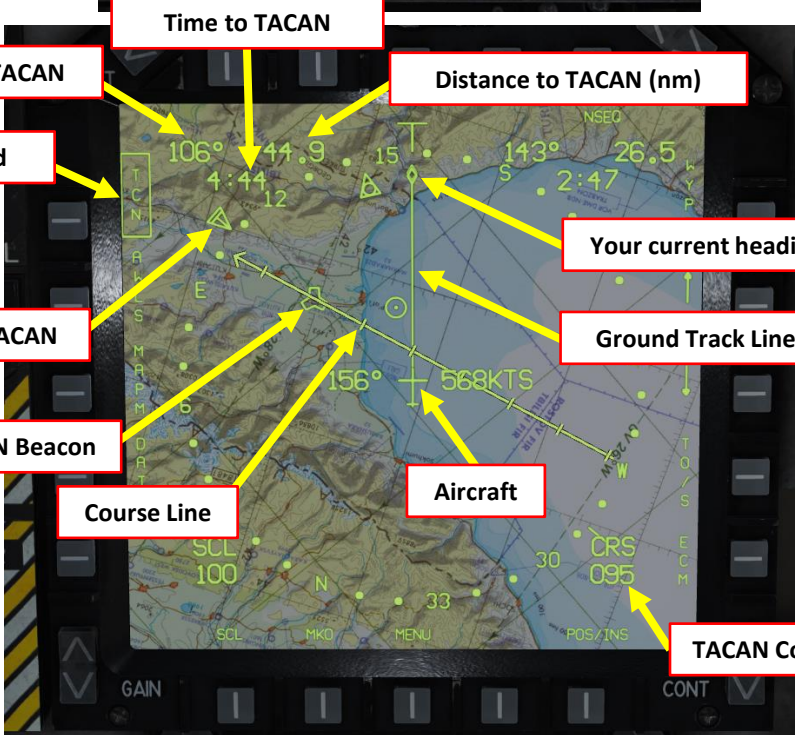

Bearing to TACAN

Time to TACAN

Distance to TACAN (nm)

TACAN Selected

Your current heading

Ground Track Line

Bearing to TACAN

TACAN Beacon

Course Line

Aircraft

TACAN Course Setting

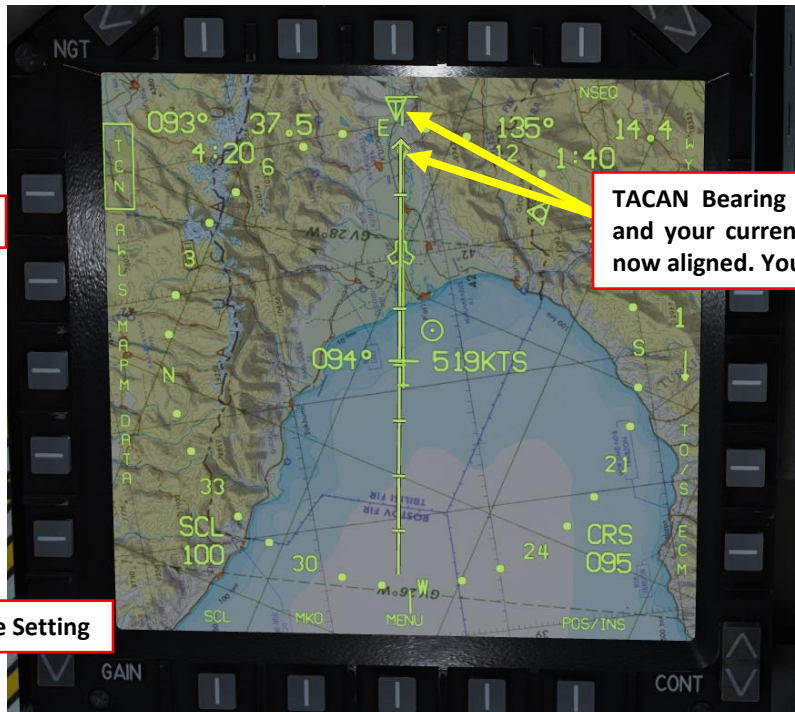

TACAN Bearing (triangle with a T) and your current heading (bar) are now aligned. You are on course!

## 7 - TACAN NAVIGATION

**Note:**

There are **five TACAN stations already preset**. You can access their information by following these steps:

1. Go in the main MENU page, then select the EHSD page
2. Press the OSB next to DATA (will become boxed when selected)
3. Press the OSB next to TCN (will become boxed when selected)
4. Select desired preset TACAN by using the OSBs next to the arrows.
5. Once you have the information you need, you can press the OSB next to DATA again to exit the TACAN DATA menu.

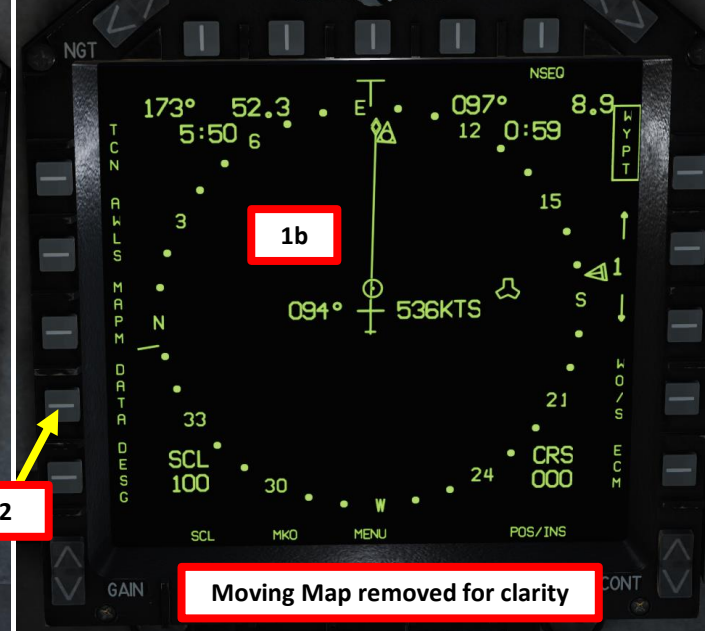
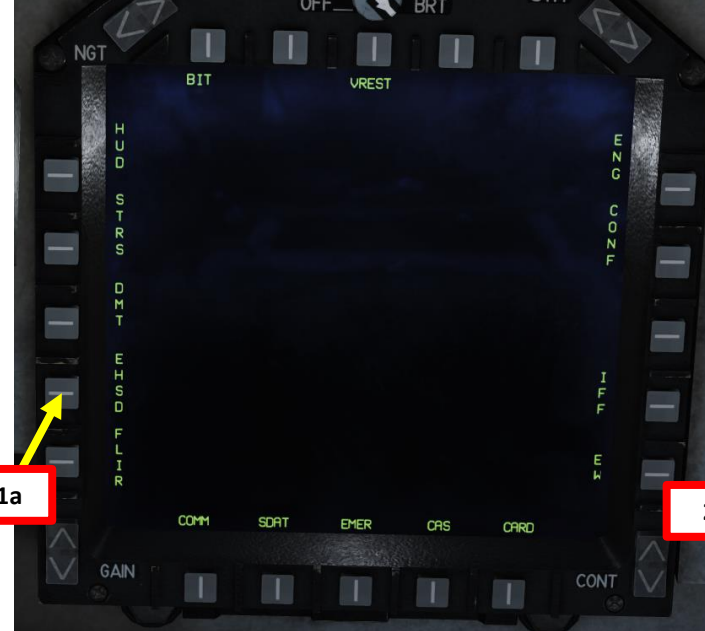

TACAN coordinates      TACAN elevation

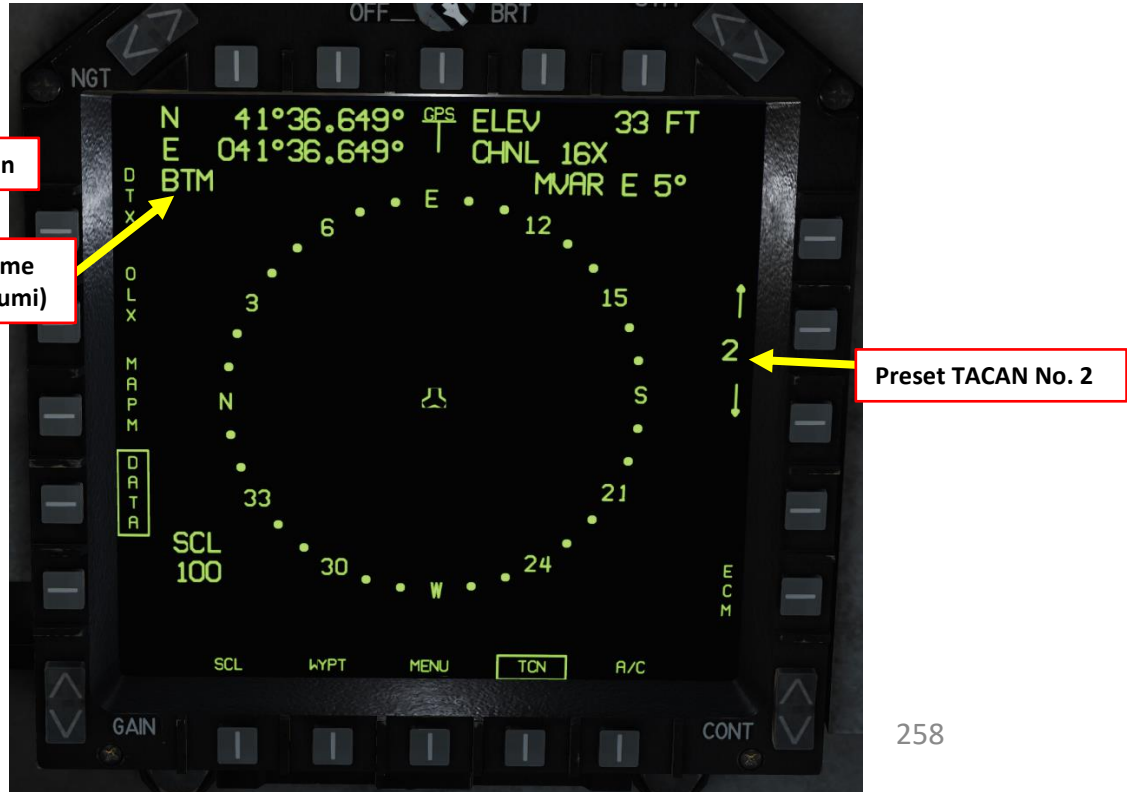
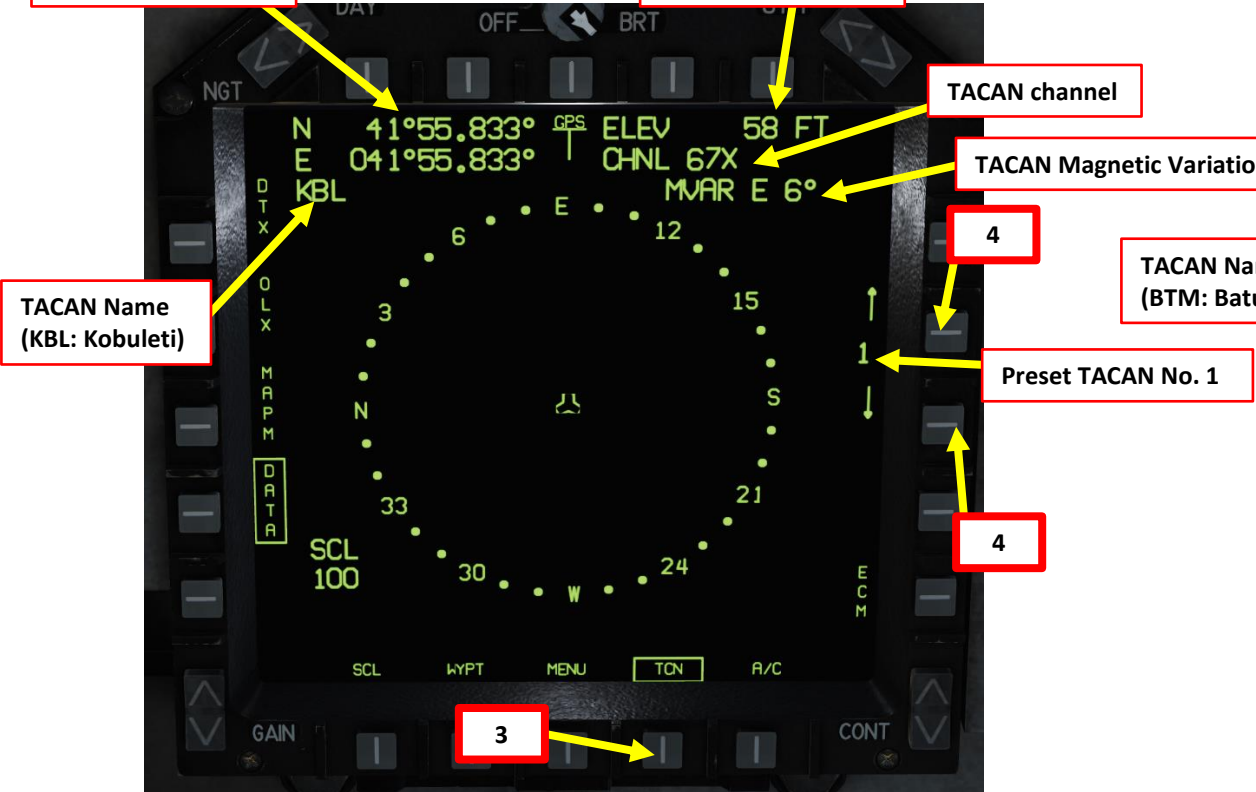

## 8 - AWLS/ILS TUTORIAL

The AWLS (All-Weather Landing System) is a similar system to the ILS (Instrumented Landing System) in concept. You have a guidance system that will help you to land in bad weather conditions. The AWLS channels are preset; you need to use the ones associated to each airfield using the table to the right. The AWLS can be used with a TACAN station to provide you additional information about range and time to arrival, but the AWLS can also be used as is.

### AWLS CONTROLS & INDICATORS

RADAR AND NIGHT ATTACK AIRCRAFT

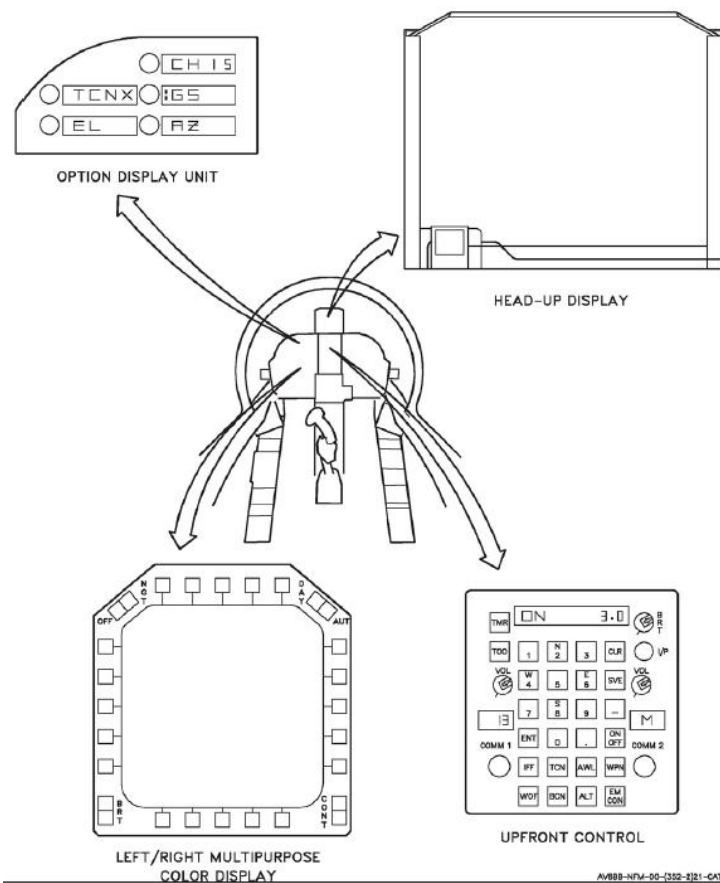

AW889-NVA-00-1250-0121-CAT

Press « RSHIFT+K » to open up kneeboard and use « [ » and « ] » to find the AWLS CHANNEL LIST page if required.

### AWLS CHANNEL LIST

CHNL	FREQ	TACAN	RUNWAY	AIRPORT
01	111.500	67X	07	KOBULETI
02	108.750	22X	13-31	VAZIANI
03	109.750	44X	08	KUTAISI
04	108.900	31X	09	SENAKI-KHOLKI
05	110.300	16X	13	BATUMI
06	110.300		13R	TIBLISI-LOCHINI
07	108.900		31L	TIBLISI-LOCHINI
08	111.700		12	MINERALNYE-VODY
09	109.300		30	MINERALNYE-VODY
10	110.500		24	MALCHIK
11	110.500		10	BESLAN
12	111.100		06	SOCHI-ADLER

### TARGET LIST

PRESS RS+RA+[8] FOR LOADING INTO AIRCRAFT

INDX	MGRS COORD	ELEV.	RECORD
NO TARGETS LOADED			

## 8 - AWLS/ILS TUTORIAL

The AWLS tutorial will be set to Senaki-Kolkhi, which is set Channel 4 to runway 09 (course: 095) with a glide slope of 3.0. We will use the TACAN station 31X too even if it is optional.

1. On UFC (Up-Front Control) scratchpad, press the AWL button and the ON/OFF button to turn on the ALWS system.
2. Press the ODU (Option Display Unit) button CH01 (it is selected when the “:” symbol is shown) to select your AWLS channel option
3. Press “4” on the UFC scratchpad, then “ENT” to set channel 04.
4. Press the ODU button GS (Glide Slope) and verify that “3.00” is entered correctly. If not, set it as shown in step 3).
5. Press the ODU button AZ (Azimuth) and input desired offset (in feet) to the runway centerline. Negative values are to the left of centerline, positive values are to the right of the centerline. In this tutorial, we will leave it as is with an offset of 0.
6. Press the ODU button TCN and input desired TACAN frequency one is available in the airfield (31X in our case) as shown in step 3).
7. Press the ODU button EL (Elevation) and input desired offset from runway elevation. In our case, we will leave it at 0.
8. Set HUD Master Mode to either NAV or VSTOL.
9. Set the runway course to 095.
10. Set appropriate scale (SCL) and press the OSB next to AWLS on the EHSD page to track the AWLS station.

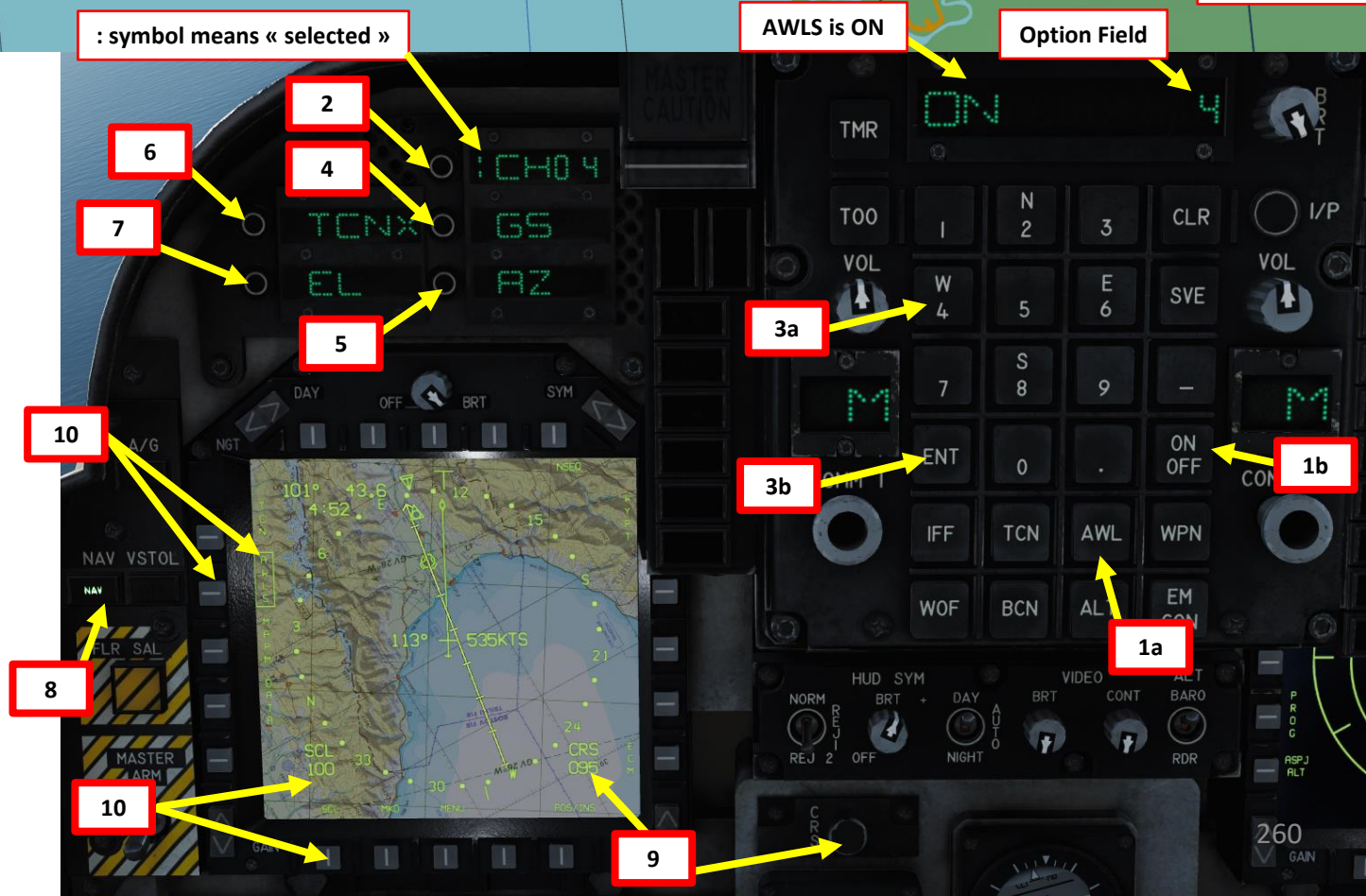

8 - AWLS/ILS TUTORIAL

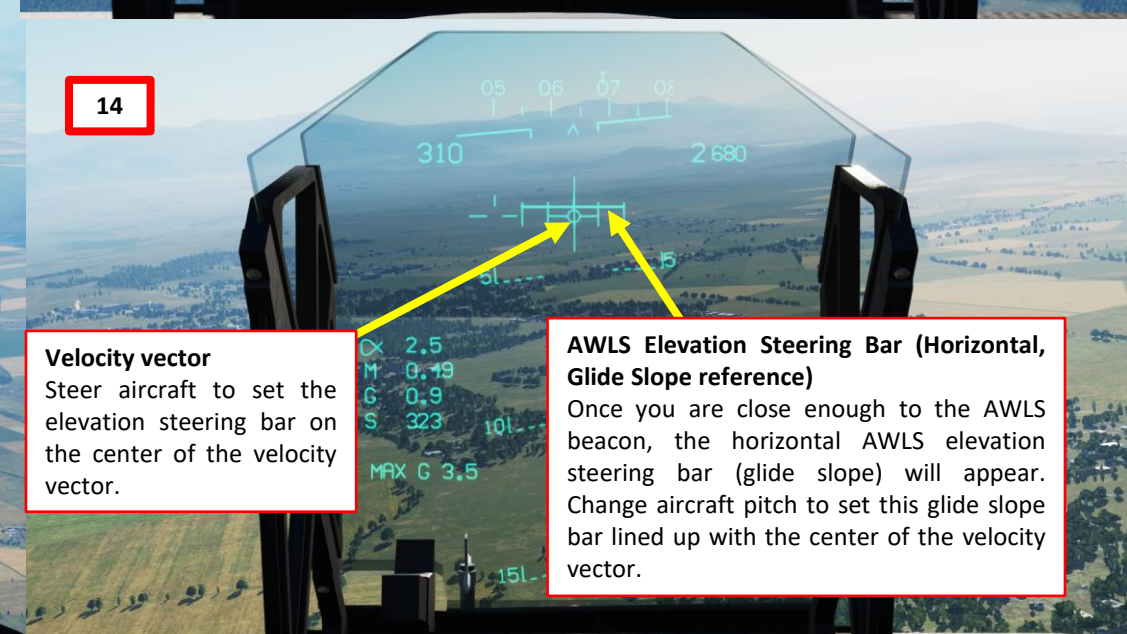
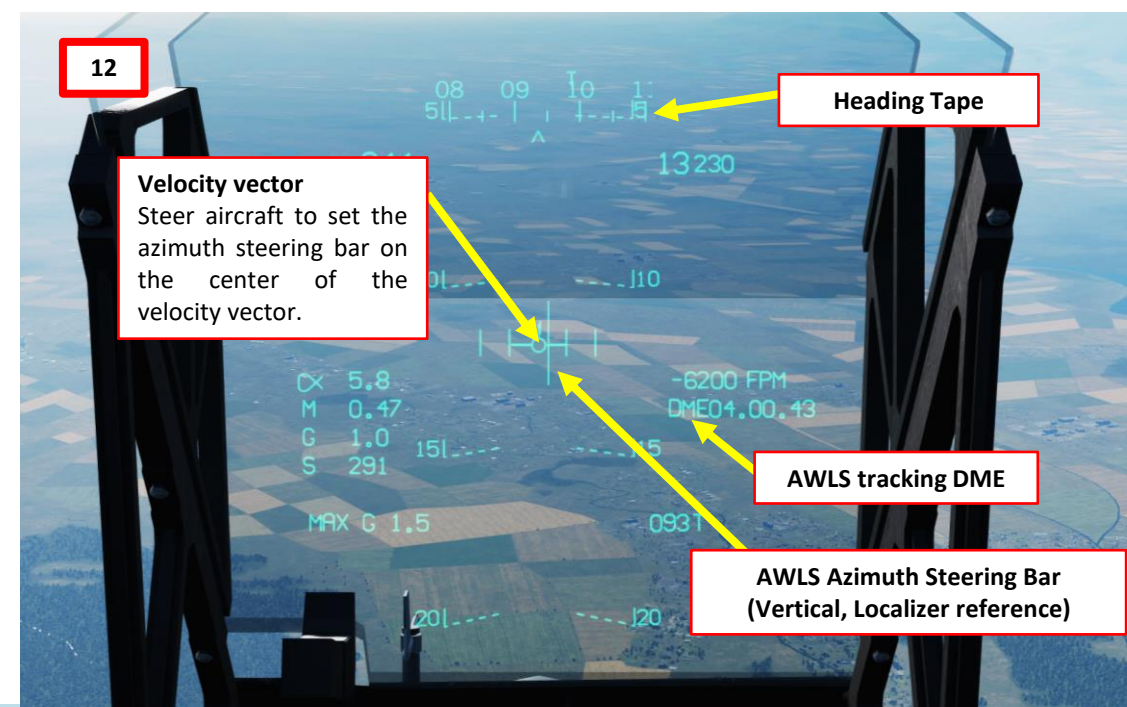
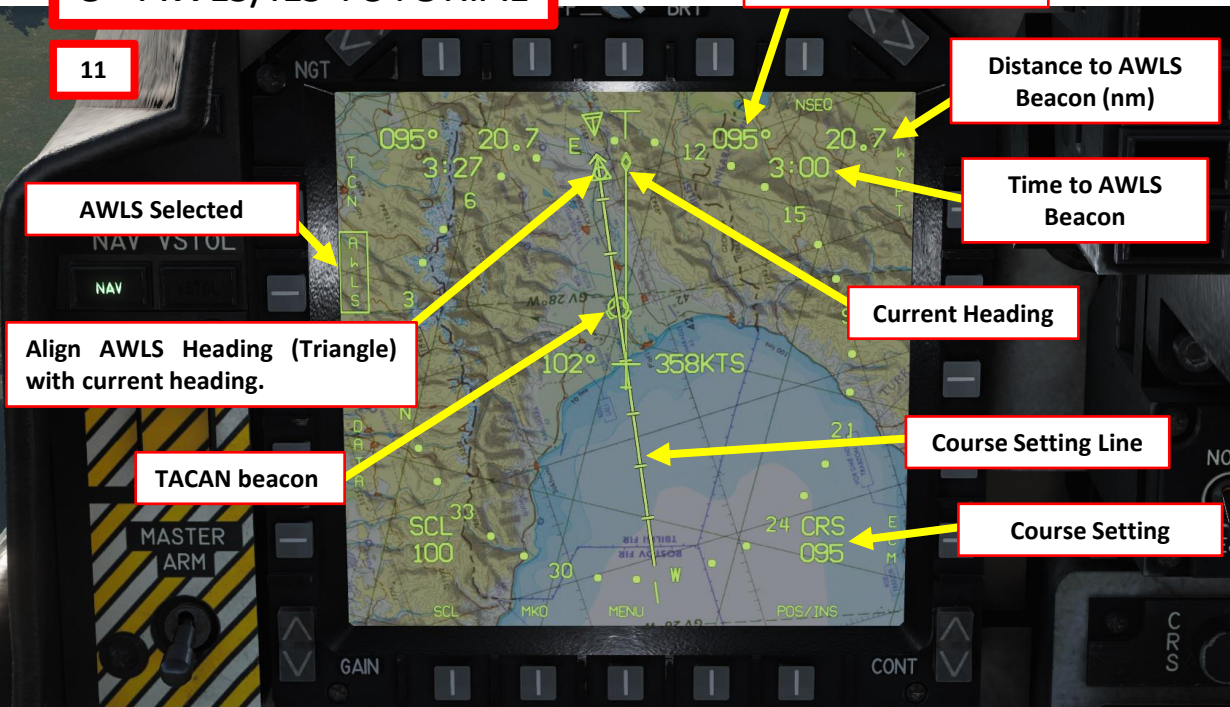

8 - AWLS/ILS TUTORIAL

14

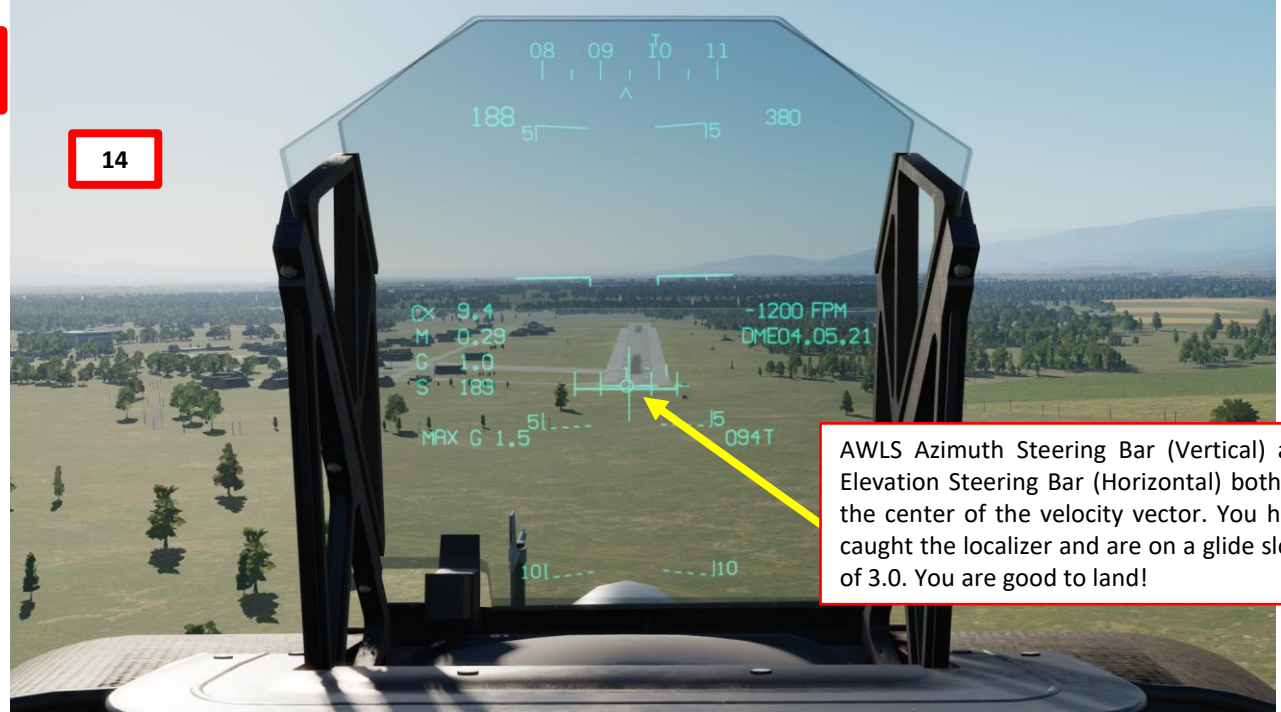

AWLS Azimuth Steering Bar (Vertical) and Elevation Steering Bar (Horizontal) both on the center of the velocity vector. You have caught the localizer and are on a glide slope of 3.0. You are good to land!



9 - BULLSEYE

A "Bullseye" is a fictional point in space used as a reference to locate yourself, friendly contacts and enemy contacts. If you know where the bullseye is and the enemy doesn't, it gives you a way to communicate positions without the enemy knowing where to look from. Your wingmen and AWACS will often refer to "bulls" or "bullseye" on the radio. A bullseye call, used to communicate your position, is done in the following format:

- Bearing from bullseye
- Range from bullseye
- Altitude

Bullseye Explanation by JediLinks: <https://youtu.be/vgcXcfeGb2M>



Allied Flight (411): 411, engaging bandit at bullseye 180 for 17, at 7000  
 Allied Flight (421): 421, engaging bandit at bullseye 199 for 26, at 7000

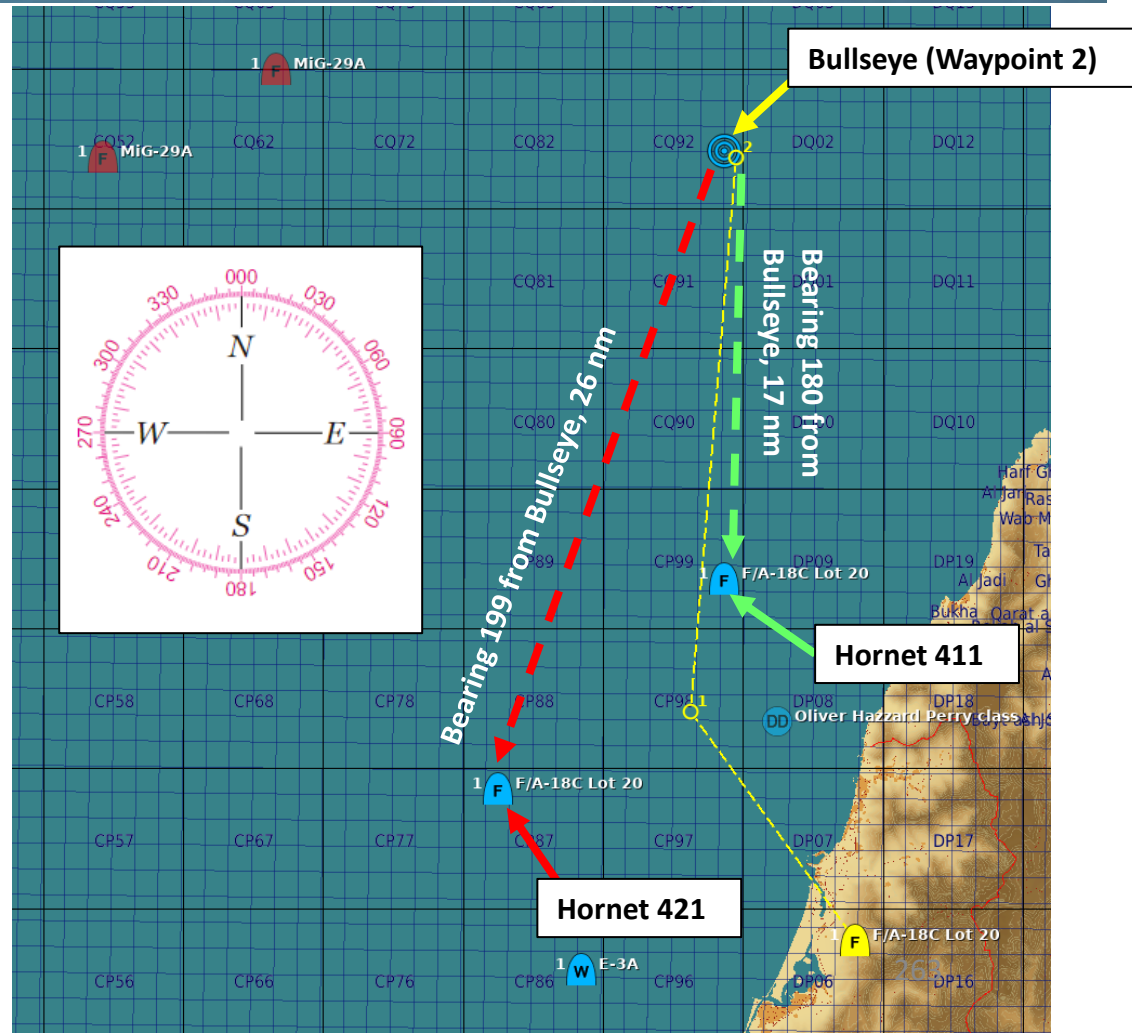

# 9 - BULLSEYE

Luckily for you, bullseye information is displayed on the Heads-Up Display while either NAV Master Mode or A/G Master Mode is active.

Take note that you can also use the Waypoint Offset function to create a reference point from Bearing and Range information from an existing waypoint (that can conveniently be placed on the Bullseye).

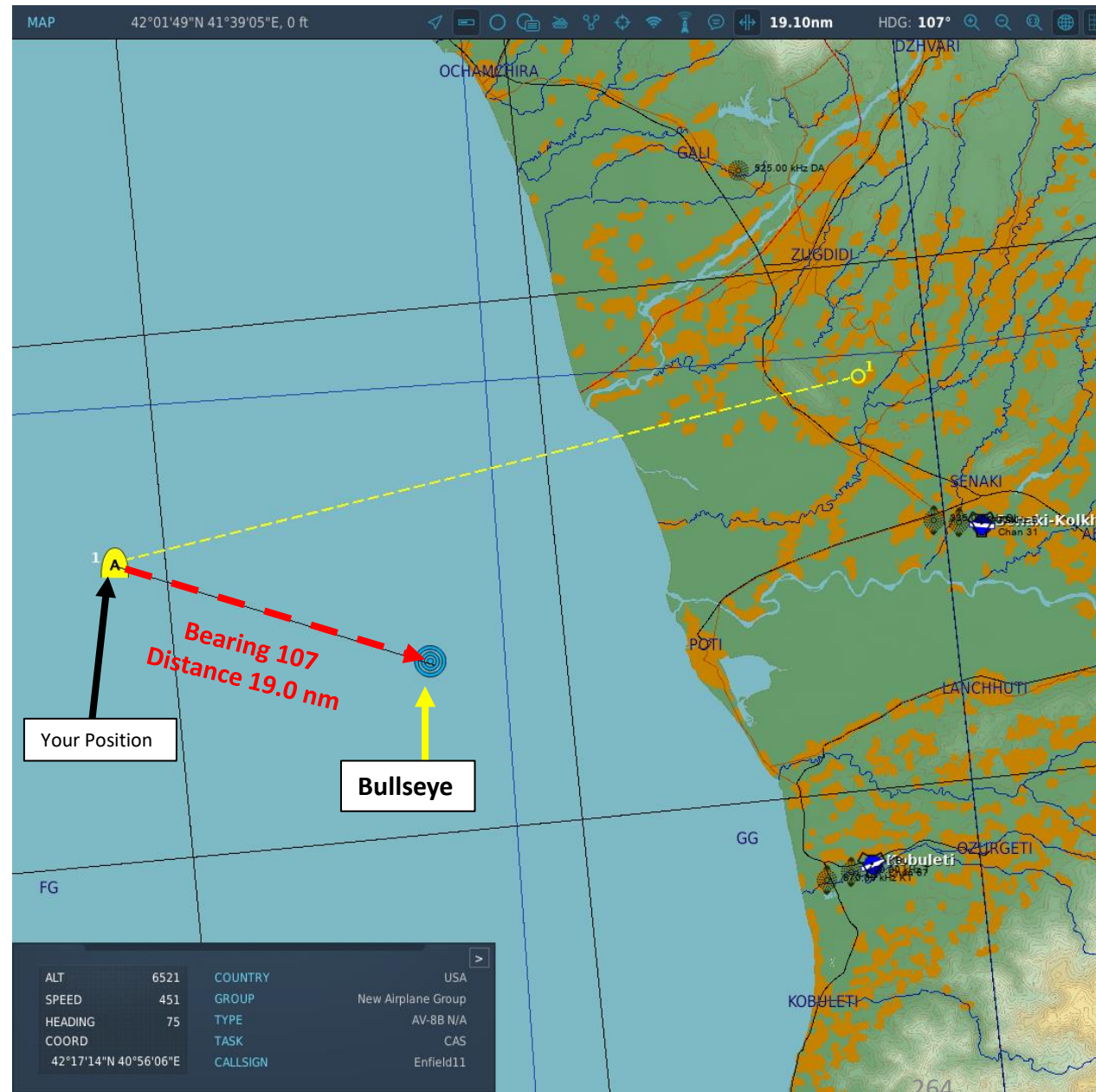
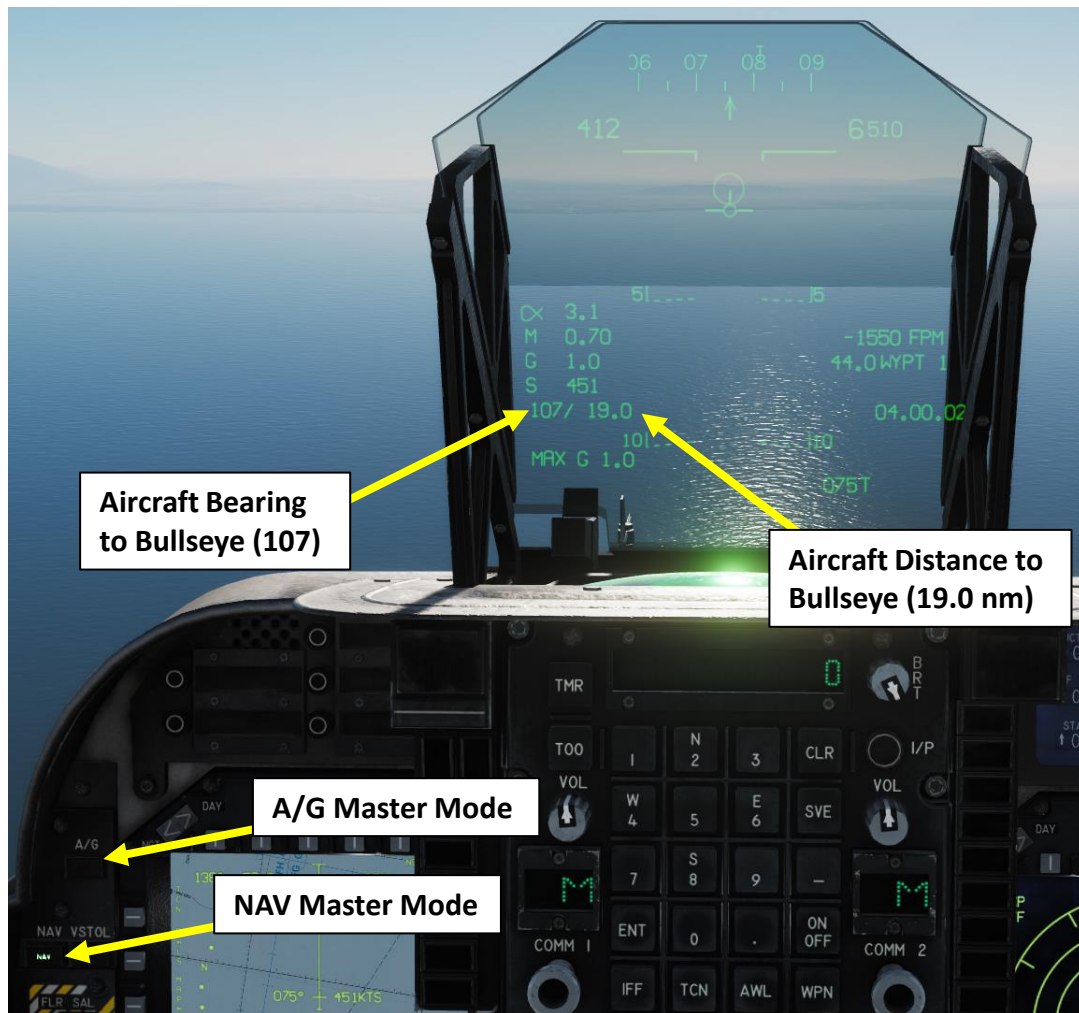

## INTRODUCTION

### AIR-TO-AIR REFUELING – WHY WE ALL HATE IT

Air-to-air refueling is one of the hardest, most hated, and most frustrating tasks in DCS. Ever. Of all time.

Why? Well, one of the main reasons for the difficulty behind refueling is the skill required to do formation flying. Flying in formation with another aircraft requires much more practice than you would initially think. Another reason is pure physics: there is this thing called “wake turbulence”. An aircraft flies through a fluid: air. Just like with any fluid, if you have something that displaces itself through it at a certain speed, the fluid will become disrupted (turbulence). Wingtip vortices and jetwash are both effects of this simple concept. Wake turbulence is the reason why airliners need to wait a minimum time between takeoffs: flying through disrupted air will destabilize the aircraft and it is unsafe, especially during critical phases of flight like takeoff and landing.

Unfortunately, wake turbulence is something a pilot has to deal with during air-to-air refueling. This is why the aircraft will fly just fine when approaching the tanker, but start wobbling around when flying in close proximity of the refueling basket/drogue and tanker engines.

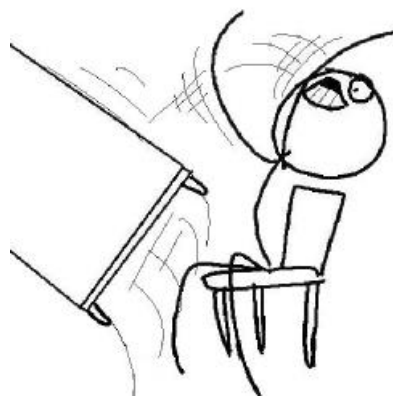

## TYPES OF AIR-TO-AIR REFUELING

- There are four main air-to-air refueling techniques used in military aviation:
  - Probe-and-drogue (refueling probe must be inserted in the tanker’s drogue basket)
  - Flying Refueling Boom (guided by boom operator aboard the tanker)
  - Buddy Refueling (two fighters can refuel one another independently without a tanker)
  - Nose-Probe refueling
- The refueling aircraft available in DCS are:
  - The Ilyushin Il-78M “Midas”, a russian **probe-and-drogue** tanker, which was developed from the Il-76
  - The Boeing KC-135 “Stratotanker”, a US Air Force **flying boom** tanker, which was developed from the Boeing 367-80
  - The Lockheed S-3B “Viking”, a US Navy **probe-and-drogue** tanker
  - The Lockheed KC-130 “Hercules”, a USMC **probe-and-drogue** tanker, which was developed from the C-130.

The Harrier is equipped with a Probe-and-Drogue system, so air-to-air refueling will only be performed from either an Il-78M, a KC-130 or a S-3B tanker.



**Il-78M**



**KC-130**



**S-3B**



Refueling Boom

*F-105 Thunderchiefs being refueled by a Boom system during the Vietnam War*



Refueling Probe

Drogue Basket

*Tornado GR4 being refueled by a Probe-and-Drogue system*

# AIR-TO-AIR REFUELING DEMO

1. Consult mission briefing to know on which radio frequency you need to contact the tanker. In our case, we will use the frequency 250 MHz on the V/UHF radio.
2. Find tanker using TACAN frequency as shown in the NAVIGATION - TACAN section.
3. Set your radio to 250 MHz and turn radio VOL knobs ON, and press "/" to communicate with TEXACO (tanker callsign).
4. Select Tanker – Texaco (F6) communication menu, and then select "Intent to Refuel"
5. TEXACO should give you a pre-contact altitude (in our case 18,000 ft).
6. Set Master Arm Switch – OFF (DOWN)
7. Set Flaps to CRUISE
8. Set A/R switch to OUT. READY light should illuminate.

Note: Some tankers like the KC-130 are equipped with a TACAN beacon, which can give you a direction to find it easily. Just make sure you have the correct TACAN frequency set in the A/A (Air-to-Air) Mode. Set TACAN using the NAVIGATION TACAN tutorial.

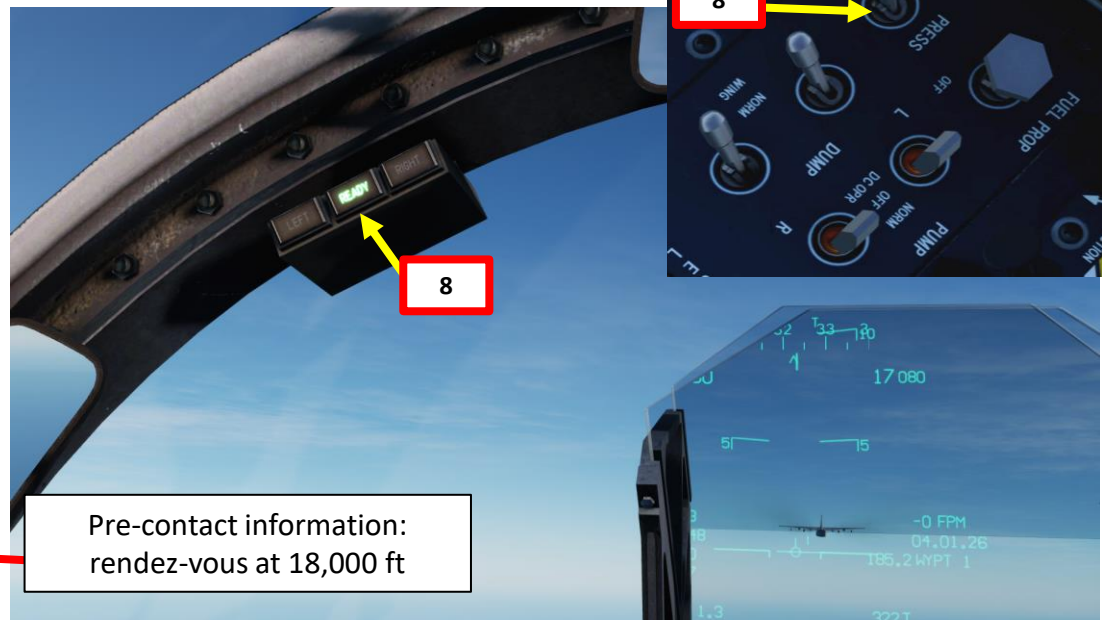
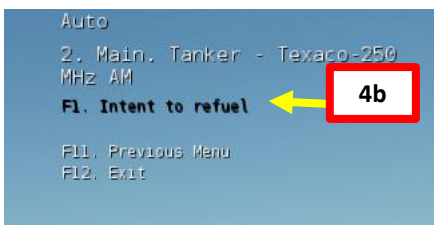
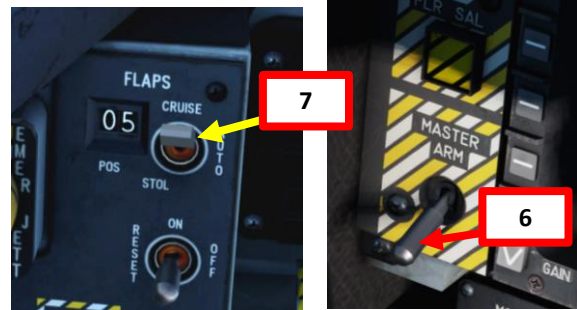

TANKER (Texaco): Enfield 1-1, Texaco, proceed to pre-contact at 18000

Pre-contact information:  
rendez-vous at 18,000 ft

5

## AIR-TO-AIR REFUELING DEMO

9. Make sure refueling probe has deployed correctly.
10. When you are less than 0.1 nm away from tanker, position yourself as shown on picture.
11. When in position, use your radio menu to select “Ready Pre-Contact” (F1).
12. The tanker’s pilot should answer you with “Cleared Contact” and should deploy his drogue basket and start to accelerate to cruising speed.
13. Fly formation with the tanker (between 190-300 KIAS) and approach the drogue basket very slowly (make sure you remain about 2-3 kts faster than the tanker) with gentle inputs. Make sure AOA (Angle of Attack) is within safe operating limits (13 deg max)
14. Keep the aircraft trimmed at ALL TIMES. Approaching untrimmed is living hell.
15. Insert your probe into the drogue basket by using your reference points.
16. Additional drag should be generated by the drogue once you have contact with the drogue: your aircraft will slightly decelerate. Once the probe is taking fuel, the tanker pilot should tell you “You’re taking fuel”.
17. Keep formation with the tanker until your refueling is complete. Refueling should be complete when the RIGHT and LEFT Refuel lights are flashing or steady.
18. Detach your probe from the basket by throttling down and set A/R switch to IN. READY light should extinguish.

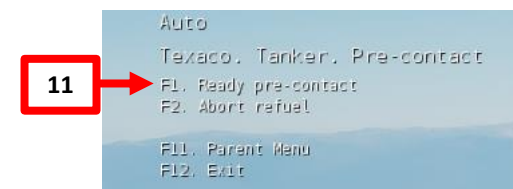
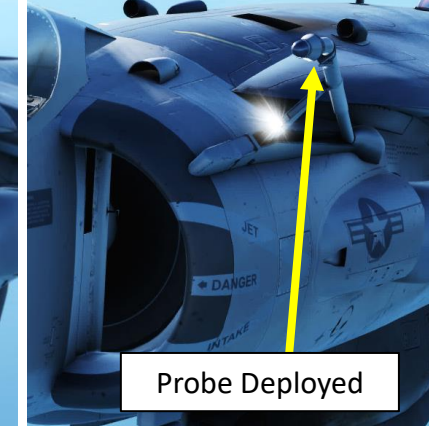
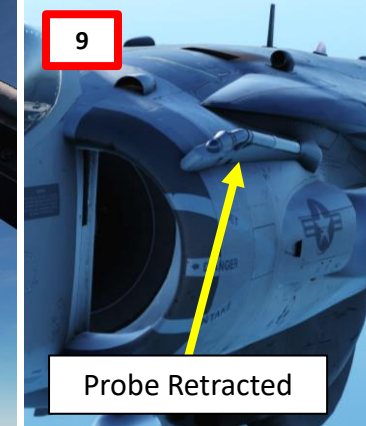

### RIGHT Refuel Light

- Flashing: internal right wing tank or right external tank is full.
- Illuminated (steady): both right wing and right external tanks are full.

### READY Refuel Light

- Illuminates when you are cleared for air-to-air refueling.
- Extinguishes during contact.

### LEFT Refuel Light

- Flashing: internal left wing tank or left external tank is full.
- Illuminated (steady): both left wing and left external tanks are full.

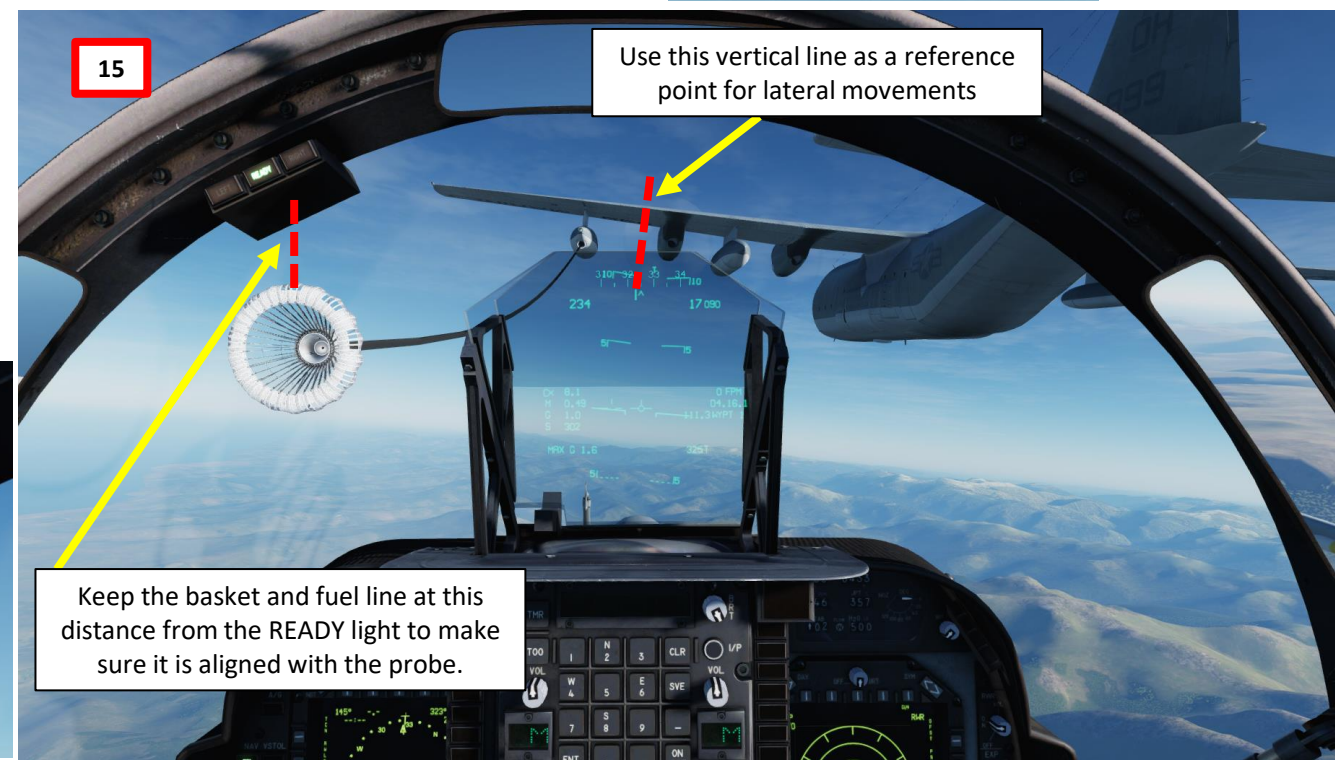
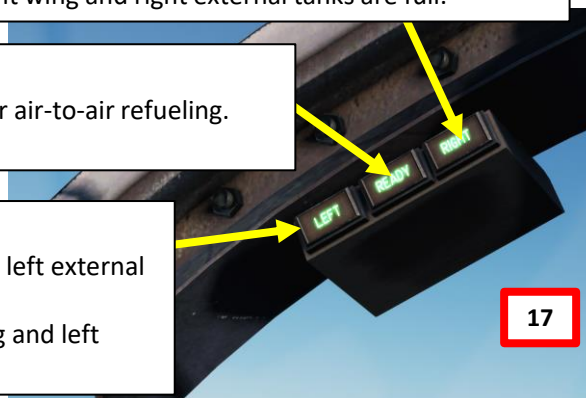

## AIR-TO-AIR REFUELING DEMO

Of course, all of this seems much easier said than done. You will very likely do following mistakes:

- Approach too fast and miss the basket
- Oscillate vertically without being able to line up with the basket
- Keep going either too fast or too slow
- Drift left or right
- Overcompensate control inputs
- Forget the airbrake on
- Forget to set the flaps at CRUISE, not AUTO

Here are various demos of air-to-air refueling.

- [https://www.youtube.com/watch?v=oLx-Q9\\_4VTU](https://www.youtube.com/watch?v=oLx-Q9_4VTU)
- <https://www.youtube.com/watch?v=JB7qUDBN3yY>
- <https://www.youtube.com/watch?v=TdJ2qXYdzdw>

The next slide will give you a couple of tips to help you catch that basket and slurp that delicious jet fuel like a crack addict.





## TIPS AND TRICKS

- Remaining **CALM is key** for a successful refueling. If you lose your cool, take a break and try again once you are relaxed. Silk hands and a clear head are needed for that part.
- If you overshoot (or are about to fly past) the tanker, you can bleed speed very fast by deploying your airbrakes. You can go from 400 kts to 300 kts in a matter of seconds.
- **Avoid rolling** your aircraft when you are tracking the basket: you will change the orientation of your lift vector and it will make you drift vertically and horizontally, which doesn't help at all. Try to stay in the same horizontal plane as much as possible.
- It is easier if you try to “break down” your control inputs in **separate movements**. I try to avoid gunning my throttle, pitching up/down and using my rudder at the same time. The aircraft reacts in a way that makes it all very difficult for your brain to predict and process. I tend to make sure my plane is **straight and level at first** and that I am more or less lined up with the basket.
- Once I have a satisfying attitude and that the basket is placed approximately as shown on the picture below, I **gradually throttle up** and increase speed to **match the tanker's speed**. In this case, the tanker's speed is 335 kts. Make sure that you keep a constant speed.
- Once my speed matches the tanker's, I can gradually accelerate to a speed that is 2-3 kts faster (338 in our case), **approaching the basket very slowly**. At that part, the **ONLY** two things I am watching are my **AIRSPEED** and the **REFERENCE POINT (NOT THE BASKET)**. Nothing else matters.
- Once I am approaching the basket, I make sure to avoid inducing rolling motions while displacing myself with the rudder and the vertical stick input **ONLY**. This way, your aircraft stays straight and delicately drifts left or right based on the **rudder input**, while you can **fine-tune your vertical attitude** with your stick.

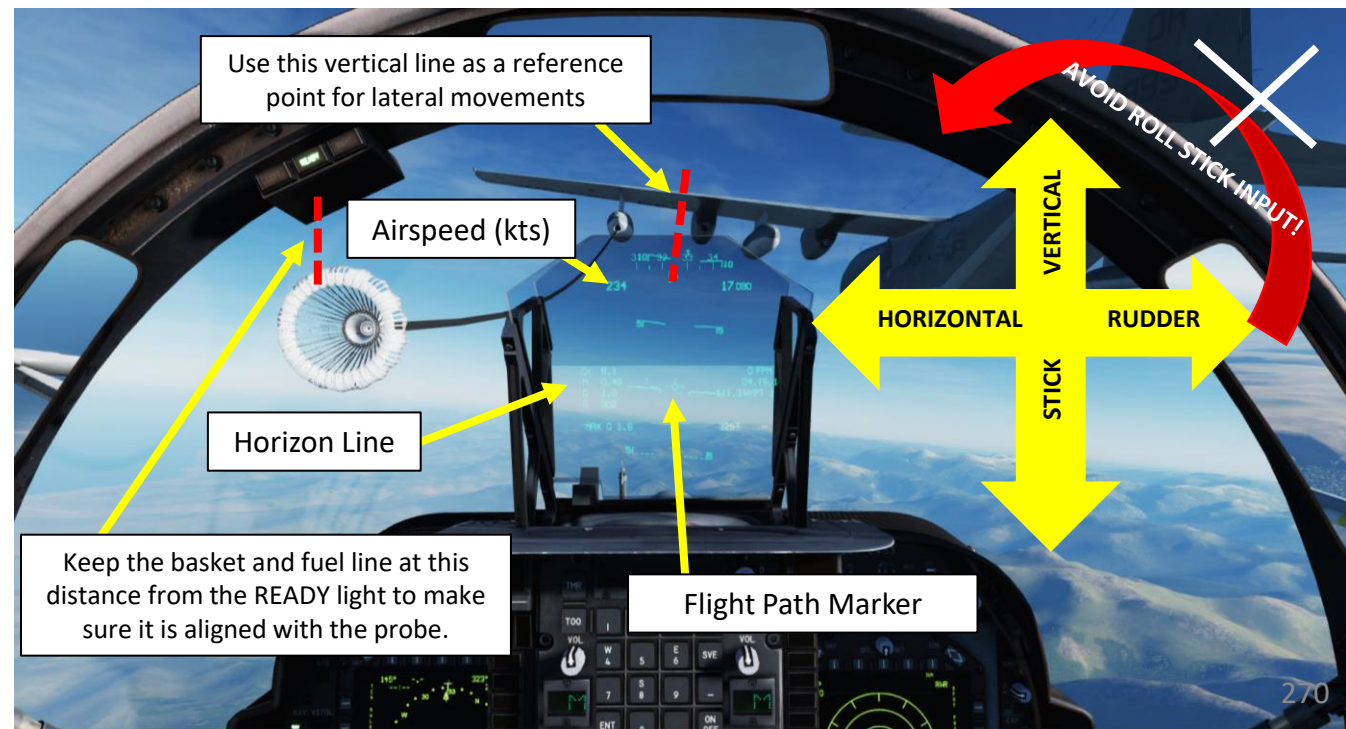

# VREST

If you go in the main Menu page, then select the VREST (Vertical/Short Takeoff & Landing, Range, Endurance, Speed & Time) page, which allows you to determine the operational capability of the aircraft. The VREST mission computer performs vertical takeoff, vertical landing, range endurance, speed and time calculations that can be consulted on the five sub-pages:

- VL: Vertical Landing Parameters
- VTO: Vertical Takeoff Parameters
- STO: Short Takeoff Parameters
- CRUS: Cruise Parameters
- BNGO: Bingo Fuel Parameters

**Note:** VREST menu is only visible if the NAV Master Mode or the VSTOL Master Mode is selected.



VSTOL Master Mode

NAV Master Mode



Main Page

VREST Page Selector

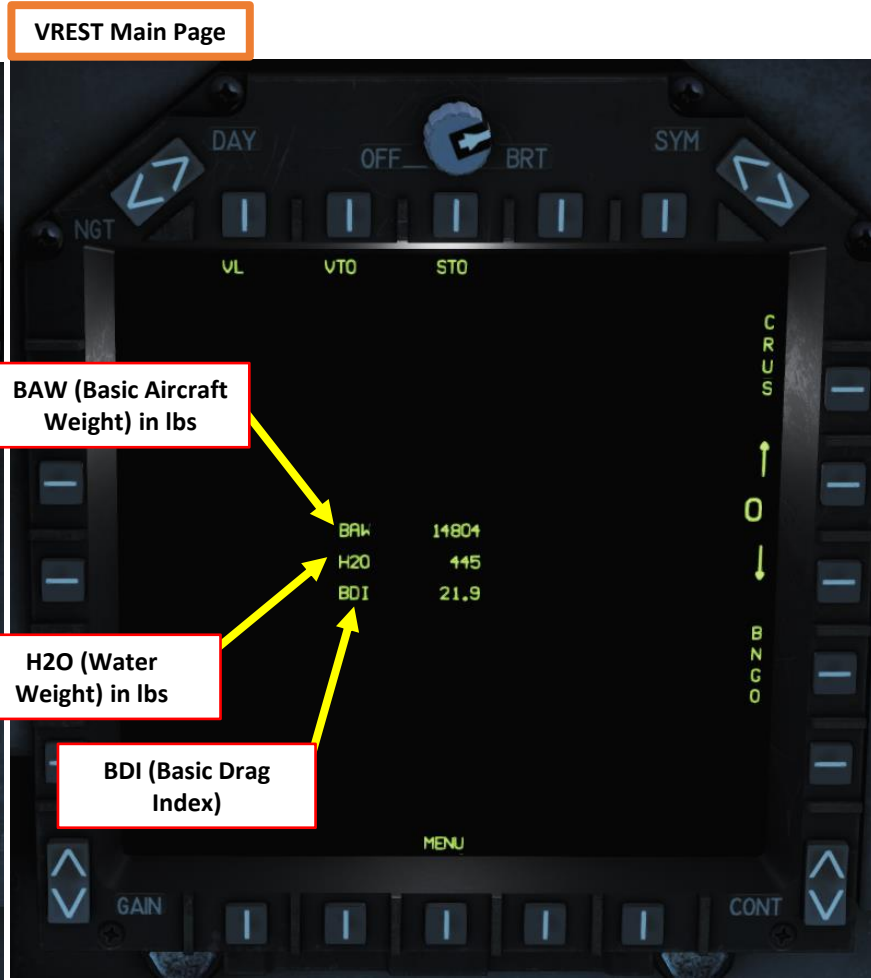

VREST Main Page

BAW (Basic Aircraft Weight) in lbs

H2O (Water Weight) in lbs

BDI (Basic Drag Index)

# VREST SUB-MENUS

## VL & VTO (VERTICAL LANDING & TAKEOFF) Pages

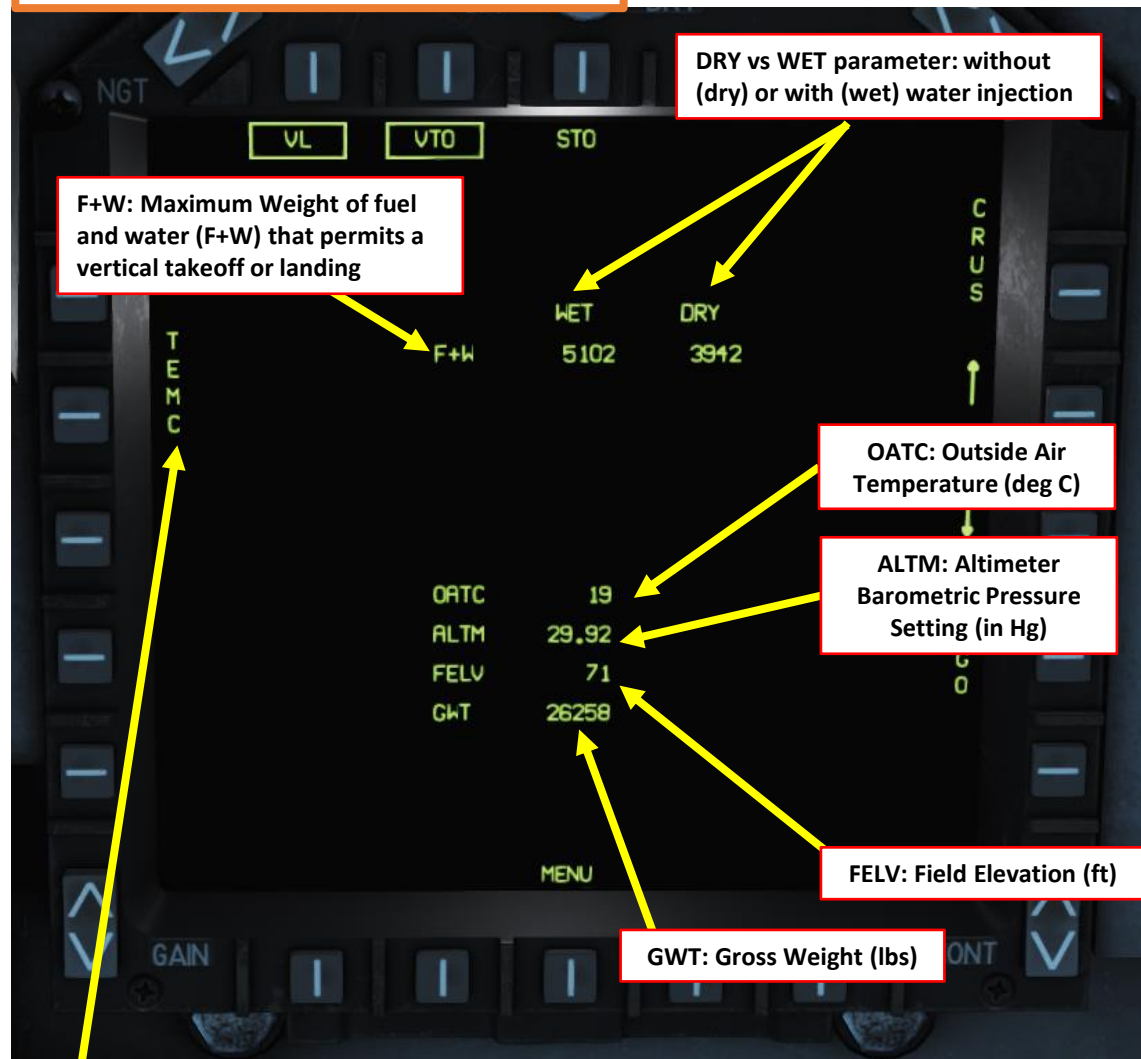

TEM C: Selects Celsius or Fahrenheit Degrees

Note: All these parameters are calculated for VERTICAL TAKEOFF & LANDING ONLY.

## VL & VTO Pages – Interface with UFC (Up-Front Controller)



Note: Data in certain field parameters can be modified manually via the UFC and the OSBs (Option Select Buttons).

# VREST SUB-MENUS

STO (SHORT TAKEOFF) Page

NOZ: Nozzle Angle (deg)

NRAS: Nozzle Rotation Airspeed (kts)

DRY vs WET parameter: without (dry) or with (wet) water injection

GROL: Ground Roll Distance (ft)

DT50: Distance required to clear a 50 foot obstacle (ft)

ASPD: Abort Speed (kts)

SDST: Stopping Distance (ft)

**RUNW: Runway Data**  
 FDAT = RDIS / RHDG / CONDITION  
 FDAT: Field Data  
 RDIS: Runway Distance (ft)  
 RHDG: Runway Heading  
 CONDITION: Runway Condition (Dry/Wet)

**Note: All these parameters are calculated for SHORT TAKEOFF & LANDING ONLY.**

	WET	DRY
NRAS	73	81
NOZ	60	60
GROL	516	610
DT50	1103	1276
ASPD	163	163
SDST	6106	6106
OATC	19	
ALTM	29.92	
FELV	65	
GWT	22580	
RUNW	07870/241DRY	
GWIND	310/004	

STO Page – Interface with UFC (Up-Front Controller)



OATC: Outside Air Temperature (deg C)

ALTM: Altimeter Barometric Pressure Setting (in Hg)

FELV: Field Elevation (ft)

GWT: Gross Weight (lbs)

GWIND: Ground Wind Data (Heading / Speed in kts)

# VREST SUB-MENUS

CRUS (CRUISE) Page

ACR: Altitude Cruise (Max Cruise Performance at existing altitude).  
 Note: \* means that existing altitude is greater than optimum altitude.

OPCR: Optimum Cruise (Max Cruise Performance at optimal altitude)

CAS: Calibrated Airspeed (kts)

Mach Number

CALT: Cruise Altitude (ft)

Range (nm)

RFUL: Remaining Fuel (lbs)

MRNG: Max Range reached if altitude, airspeed and Mach are followed

WIND: Heading / Wind Speed (kts)

GWT: Gross Weight (lbs)

DI: Drag Index

	ACR	OPCR
CAS	519 KT	271 KT
MACH	0.79	0.79
CALT	252 FT	34294 FT
RANG	0 NM	0 NM
RFUL	2000 #	7625 #
MRNG	250 NM	837 NM
WIND	179/000	087/008
GWT	26253	DI 18.5

CRUS Page – Interface with UFC (Up-Front Controller)



Note: All these parameters are calculated for the CRUISE phase of flight.

# VREST SUB-MENUS

BNGO (BINGO) Page

ABNG: Altitude Bingo (Max Bingo Fuel Performance at existing altitude).  
 Note: \* means that existing altitude is greater than optimum altitude.

OBNG: Optimum Cruise (Max Bingo Fuel Performance at optimal altitude)

	ABNG	OBNG
CAS: Calibrated Airspeed (kts)	150 KT	130 KT
Mach Number	0.65	0.60
CALT: Cruise Altitude (ft)	20000 FT	30000 FT
Range (nm)	20 NM	20 NM
RFUL: Remaining Fuel (lbs)	2000 #	2250 #
MRNG: Max Range reached if altitude, airspeed and Mach are followed	250 NM	300 NM
WIND: Heading / Wind Speed (kts)	179/000	087/008
DCRG: Descent Range (nm)	10 NM	13 NM
GWT: Gross Weight (lbs)	26250	DI 18.5

BNGO Page – Interface with UFC (Up-Front Controller)



Note: All these parameters are calculated for the BINGO flight profile. BINGO is “an order to proceed and land at the field specified, utilizing a bingo profile. Aircraft is considered to be in an emergency/fuel critical situation. Bearing, distance, and destination shall be provided.”

## USEFUL RESOURCES

### A1-AV8BB-NFM-000

NATOPS Flight Manual

### A1-AV8BB-NFM-400

NATOPS Flight Manual Performance Charts

### 476th vFG AV-8B Flight Crew Checklist

<http://www.476vfightergroup.com/downloads.php?do=file&id=485>

### RAZBAM (Official Developer) Work-In-Progress Pocket Guide

<https://forums.eagle.ru/showthread.php?t=193603>

### Redkite's Youtube Tutorials

[https://www.youtube.com/watch?v=WJBPRZMM-8U&list=PLml\\_c09ciucvv3ClSWImCEqY5XIdbfPxu](https://www.youtube.com/watch?v=WJBPRZMM-8U&list=PLml_c09ciucvv3ClSWImCEqY5XIdbfPxu)

### Jabbers' Youtube Tutorials

<https://www.youtube.com/channel/UCvXXUrGCF3wV3bbZ6pFQ00g/videos>

### Maverick's Air-to-Air Refueling Tutorial

[https://www.youtube.com/watch?v=oLx-Q9\\_4VTU](https://www.youtube.com/watch?v=oLx-Q9_4VTU)

# THANK YOU TO ALL MY PATRONS

Creating these guides is no easy task, and I would like to take the time to properly thank every single one of my [Patreon](#) supporters. The following people have donated a very generous amount to help me keep supporting existing guides and work on new projects as well:

- [ChazFlyz](#)
- Harold Harding
- Chris Partridge

# AV-8B NIGHT ATTACK V/STOL

- INSTANT ACTION
- CREATE FAST MISSION
- MISSION
- CAMPAIGN
- MULTIPLAYER

- LOGBOOK
- ENCYCLOPEDIA
- TRAINING
- REPLAY

- MISSION EDITOR
- CAMPAIGN BUILDER

EXIT



Nevada 2.2.0 A-10C 2.5.0 AJS37 2.5.0 AV8BNA Beta 2.5.0 Bf 109 K-4 2.5.0 C-101 2.5.0 Beta CA 2.5.0 Caucasus 2.5.0 F-5E 2.5.0 F-86F 2.5.0 FC3 2.5.0 Fw 190 D-9 2.5.0 Hawk 2.5.0 Beta Ka-50 2.5.0 L-39 2.5.0 M-2000C 2.5.0 MI-8MTV2 2.5.0